



**UNION INTERNATIONALE**

**MOTONAUTIQUE**

**CIRCUIT**

**RULES**

2010

## 2009 CIRCUIT WORLD CHAMPIONS

### Formula 1



CAPPELLINI  
Guido  
Italy

### Formula 2



COENRADI  
Johan  
Netherlands

### Formula 4



CURTIS  
Scott  
Great Britain

### Formula 500



JUNG  
Marian  
Slovakia

### Formula 1000



CARELLA  
Alex  
Italy

### O 125



AABRAMS  
Erko  
Estonia

### O 175



BEHNCKE  
René  
Germany

### O 250



BEHNCKE  
René  
Germany

### O 350



CHIURI  
Salvatore  
Italy

### O 700



HAVAS  
Attila  
Austria

### OSY 400



BAZINSKY  
Miroslav  
Slovakia

### S 550



GUTMANIS  
Lauris  
Latvia

### SST 45



NELSON  
Jason  
USA

### SST 120



FOX  
Jay  
USA

### GT 30



ELISSON  
Tobias  
Sweden

## 2009 CIRCUIT WORLD CHAMPIONS

### JT 250



SMILSKALNS  
Toms  
Latvia

### T 400



MAKINEN  
Ville  
Finland

### T550



RAUDVA  
Art  
Estonia

### F-4S



HAGIN  
Stefan  
Germany

### APBA Sports C



HUNTING  
Allan  
USA

### APBA Unlimited Hydroplanes



KELLY  
J.Michael  
USA

### Grand Prix Hydroplane



NIDDRIE  
Brett  
Australia

### Jet Sprint Superboat



CAUGHEY  
Peter  
New Zealand

### Jet Sprint Class A



STANLEY  
Slade  
Australia

### PR 550



MASABEU  
TIERNO  
Ricard  
Spain

### P750 - Class Standard



BUTLER  
Gordon  
South Africa

### P750 - Class Blueprint



CLOETE  
Dylan  
South Africa

### P750 - Class Modified



BALL  
Lionel  
South Africa



TELLEZ  
GRAMAGE  
David  
Spain



MULLER  
Werner  
South Africa



COLLINS  
Lyndon  
South Africa



NDESI  
Bongani  
South Africa

**2009 CIRCUIT ENDURANCE WORLD CHAMPIONS****Class 1**

AIME  
Fabrice  
France



JULTIER  
Sébastien  
France



MANCHON  
Matthieu  
France



MOREAU  
Brice  
France

**Class 2**

BOURDIN  
Tony  
France



DELAMBRE  
Franck  
France



DOUBLET  
Eric  
France



LEMOINE  
Sébastien  
France

**Class 3**

DESSERTENNE  
Philippe  
France

## 2009 RIVER MARATHON WORLD CHAMPIONS

### Class A



MURDOCH  
James  
New Zealand

### Class B



SUTHERLAND  
Jonnie  
New Zealand

### Class C



DAVIDSON  
Kruse  
New Zealand

### Class D



MORRISON  
Araon  
New Zealand

### Class Unlimited



KING  
Spencer  
Canada

## 2009 FORMULA FUTURE WORLD CHAMPIONS

### Class 1



ARKHIPOV  
Gleb  
Russia

### Class 2



NIKITIN  
Artem  
Russia

### Class 3



KELLE  
Jonas  
Germany

### Class 4



KAZIMOV  
Georgy  
Russia

### Class 5



MELNIKOV  
Daniil  
Russia

## 2009 ENDURANCE PNEUMATICS WORLD CHAMPIONS

### Class 1



KISARI  
Gábor  
Hungary



OVCHINNIKOV  
Alexandr  
Russia



TABORI  
Áron  
Hungary



TÖRJEK  
Szilveszter  
Hungary

### Class 2



GOSY  
Árpád  
Hungary



LENGYEL  
Laszlo  
Hungary



SANDOR  
Peter  
Hungary

### Class 3



MAMI OF  
Nikolay  
Russia



MARSHEV  
Viktor  
Russia



SAZONOV  
Oleg  
Russia



ZHAZHKOV  
Boris  
Russia

### Class 4



GERASHCHENKO  
Andrey  
Russia



KREKNIN  
Sergey  
Russia

### Class 5



AVAKYAN  
Artur  
Russia



IVONINSKIY  
Aleksander  
Russia



OVCHINNIKOV  
Andrey  
Russia



SHLOM  
Vadim  
Russia

## 2009 CIRCUIT EUROPEAN CHAMPIONS

### Formula 125



SYNORACKI  
Henryk  
Poland

### Formula 250



BEHNCKE  
René  
Germany

### Formula 350



CHIURI  
Salvatore  
Italy

### Formula 1000



DEL PIN  
David  
Italy

### Formula R1000



KASCHUBE  
Udo  
Germany

### Formula OSY



KOSUT  
Michal  
Slovakia

### JT 250



EGLE  
Ivo  
Latvia

### O 500



TROMBETTA  
Tiziano  
Italy

### O 700



HAVAS  
Attila  
Austria

### S 550



RYBARCZYK  
Lechoslaw  
Poland

### T 400



MANNINEN  
Juha-Pekka  
Finland

### T 550



GEMBIAK  
Michal  
Poland

## 2009 CIRCUIT EUROPEAN CHAMPIONS

T 850



SANDOR  
Peter  
Hungary

P 750



SJOGREN  
Roland  
Sweden

Formula 2 Middle East



AL RUBAYAN  
Yousef  
Kuwait

## 2009 FORMULA FUTURE EUROPEAN CHAMPIONS

Class 1



BECHLER  
Johan  
Germany

Class 2



NIKITIN  
Timofey  
Russia

Class 3



REH  
Steven  
Germany

Class 4



KAZIMOV  
Georgiy  
Russia

Class 5



COVINI  
Matteo  
Italy



## 2009 EUROPEAN ENDURANCE PNEUMATICS

### Class 1



KONOPLYANTSEV  
Nikita  
Russia



SMIRNOV  
Alex  
Russia



SMIRNOV  
Jyri  
Russia



VASILENKO  
Alex  
Russia

### Class 2



GOSY  
Árpád  
Hungary



LENGYEL  
Laszlo  
Hungary

### Class 3



EFIMKIN  
Boris  
Russia



KASHIN  
Ilya  
Russia



MATVEEV  
Stas  
Russia



SVETASHOV  
Vladimir  
Russia

### Class 5



ESAYAN  
Armen  
Armenia



VANDYSHEV  
Dmitri  
Russia



VANDYSHEV  
Roman  
Russia

# INDEX

**CODE OF ETHICS.....23**

**ANTI-DOPING RULES.....31**

## **GROUP 100 - U.I.M. ADMINISTRATION**

<b>101</b>	<b>U.I.M. EVENT SANCTIONS AND THE SPORTS CALENDAR.....</b>	<b>111</b>
	101.01 - EVENT SANCTION REQUIREMENTS AND FEES	
	101.02 - OTHER MEETINGS	
	101.03 - DEADLINE DATES	
	101.04 - LATE REQUEST, CHANGE OF DATE AND CANCELLATION	
<b>102</b>	<b>U.I.M. COMMISSIONER .....</b>	<b>114</b>
	102.01 - GENERAL	
	102.02 - FUNCTIONS	
	102.03 - AFTER THE RACE	
	102.04 - ACCOMMODATION AND TRAVEL	
<b>103</b>	<b>RACES RECOGNISED BY THE U.I.M. ....</b>	<b>118</b>
<b>104</b>	<b>NON APPROVED RACES.....</b>	<b>119</b>
<b>105</b>	<b>TITLED INTERNATIONAL EVENTS.....</b>	<b>120</b>
<b>106</b>	<b>INTERNATIONAL CHAMPIONSHIPS, WORLD AND CONTINENTAL CUPS.....</b>	<b>121</b>
	106.01 - GENERAL RULES	
	106.02 - WATER REGISTRATION	
<b>107</b>	<b>WORLD CHAMPIONSHIP .....</b>	<b>126</b>
<b>108</b>	<b>CONTINENTAL AND WORLD CHAMPIONSHIPS.....</b>	<b>127</b>
	108.01 - NUMBER OF CHAMPIONSHIPS	
	108.02 - EUROPEAN CHAMPIONSHIP SERIES	
	108.03 - ENTRIES	
	108.04 - HEATS AND LENGTH	
	108.05 - REPAIRS AND MEASURING	
	108.06 - RESULTS	

111	<b>RESERVE NUMBER</b> .....	131
112	<b>RULES FOR DRAG RACES</b> .....	131
	112.01 - DEFINITIONS	
120	<b>RACING LICENCES</b> .....	132
	120.01 - COMPULSORY LICENCE	
	120.02 - REGISTRATION	
	120.03 - VALIDITY OF LICENCES	
	120.04 - COST OF LICENCE	
	120.05 - EXAMINATION OF LICENCES	
	120.06 - CANCELLATION OF LICENCE	
	120.07 - PSEUDONYM	
	120.08 - SUPER-LICENCE ENDORSEMENT FOR WORLD FORMULA SERIES RACING	

## GROUP 200

200	<b>RACE ORGANISATION</b> .....	135
	200.01 - GENERAL	
	200.02 - INTERPRETATION OF THE RULES	
201	<b>ORGANISING BODIES</b> .....	136
	201.01 - RACE COMMITTEE	
	201.02 - INTERNATIONAL OFFICERS LISTS	
	201.03 - THE OFFICER OF THE DAY (O.O.D.)	
	201.04 - THE DEPUTY OFFICER OF THE DAY	
	201.04.01 - THE MEDICAL OFFICER	
	201.05 - THE RACE SECRETARY	
	201.06 - DUTIES OF THE RACE OFFICIALS	
	201.07 - THE TECHNICAL OFFICERS	
	201.08 - THE BUOY AND COURSE OFFICERS	
	201.09 - THE TIMEKEEPERS AND STARTER	
202	<b>ADVANCE-PROGRAMME</b> .....	140
	202.01 - FORWARDING DATE	
203	<b>ENTRIES</b> .....	143
	203.01 - RATIFICATION	
	203.02 - ADMISSION	
	203.03 - ENTRY FREE	
	203.04 - MINIMUM AGE	
	203.041 - MINIMUM AGE INTERNATIONAL	
	203.05 - NATIONALITY	
	203.051 - PUBLICITY ON THE BOATS	

204	<b>RACE INSTRUCTIONS</b> .....	145
205	<b>SAFETY RULES</b> .....	147
	205.01 - ANNUAL MEDICAL EXAMINATION	
	205.02 - MEDICAL EXAMINATION AT EVENT	
	205.02.01 - MEDICAL EXAMINATION FOR SUPERLICENCE	
	205.02.02 - DOPING TEST CONSUMPTION OF ALCOHOL	
	205.02.03 - ANTI-DOPING REGULATIONS	
	205.03 - MEDICAL EVALUATION SHEET	
	205.04 - GENERAL OBJECTIVE EXAMINATION	
	205.05 - UNDERWATER TRAINING	
	205.06 - LIFE JACKET	
	205.07 - PROTECTING HELMET	
	205.08 - SAFETY BOATS	
	205.08.01 - TOWING BOATS	
	205.08.02 - FIRST AID STATION	
	205.09 - INSURANCE	
	205.10 - TECHNICAL PROTECTION	
	205.11 - CLOTHING PROTECTION	
	205.12 - LIFTING OF RACEBOATS	
206	<b>NATIONALITY AND RACE NUMBERS</b> .....	158
	206.01 - NATIONALITY	
	206.02 - NUMBERS	
	206.03 - LOSS OF RACE NUMBER	
	206.04 - U.I.M. STICKERS	

## **GROUP 300**

300	<b>RULES FOR CIRCUIT RACES</b> .....	160
	300.01 - DEFINITIONS	
301	<b>TIMING</b> .....	161
302	<b>CIRCUIT</b> .....	162
	302.02 - RACE CONTROL	
303	<b>MARKS OF THE COURSE</b> .....	163
	303.01 - DEFINITIONS	
304	<b>SIGNALS FROM THE SHORE</b> .....	164
	304.01 - CALL SIGNALS	
	304.02 - FLAG SIGNALS	
	304.03 - STARTING IN GROUPS	

305	THE START .....	166
306	FLYING START WITH CLOCK, DISCS AND GUN .....	167
	306.01 - PLACE OF THE CLOCKS	
	306.02 - DISCS	
	306.03 - GUN	
	306.04 - STARTING LINE	
	306.05 - SAFETY ZONE	
	306.06 - BEFORE THE START	
	306.07 - THE START	
	306.08 - APPROACHES TO THE STARTING LINE	
	306.09 - BOAT STARTING BEFORE TIME	
307	DEAD ENGINE START FROM A QUAY, A JETTY OR A BEACH ..	171
309	RACE POSTPONED .....	178
310	RACE SHORTENED .....	179
311	RACE STOPPED AND RE-STARTS.....	179
	311.01 - GENERALITY	
	311.02 - RACING IN HEATS	
	311.03 - SINGLE HEAT RACING	
312	RULES OF THE ROAD.....	182
	312.02 - OVERLAP	
	312.08 - OVERTAKING	
	312.11 - PASSING MARKS	
	312.12 - ALTERING COURSE	
313	ROUNDING AND FOULING MARKS .....	184
314	FOULING COMPETING BOATS.....	185
315	MEANS OF PROPULSION .....	185
316	YELLOW FLAG SITUATION IN PRACTICE / TIME TRIAL.....	185
317	FINISHING A RACE .....	186
	317.01 - THE FINISH	
318	SCORING SYSTEM .....	187
319	DEAD-HEAT .....	189
320	POSTING OF THE RESULTS .....	190

321	INSPECTION OF HULLS AND ENGINES .....	190
322	PRIZES .....	192
323	REPORTS.....	192
<b>GROUP 400</b>		
400	JURISDICTION.....	194
402	JUDICIAL BODIES.....	194
	402.01 - THE INTERNATIONAL JURY	
	402.02 - INTERESTED PARTIES	
	402.03 - THE U.I.M. APPEALS BOARD	
403	PROTEST PROCEDURES.....	196
	403.01 - VALIDITY OF PROTESTS	
	403.02 - PROTEST FEE	
	403.03 - RIGHT OF PROTEST	
	403.04 - TIME TO LODGING A PROTEST	
	403.05 - JUDGEMENT	
	403.06 - NOTIFICATION OF DECISION	
	403.07 - AVAILABILITY OF DOCUMENTS	
	403.08 - RETURN OF FEES	
404	HEARING OF THE PROTEST.....	199
	404.01 - RIGHT TO A HEARING	
	404.02 - EVIDENCE	
	404.03 - THE HEARING PROCEDURE	
405	THE APPEALS PROCEDURE .....	200
	405.01 - APPEAL BOARD	
	405.02 - INTERESTED PARTIES	
	405.03 - RIGHT OF APPEAL	
	405.04 - NOTICE OF INTENTION TO APPEAL	
	405.05 - TIME LIMIT	
	405.06 - LODGING OF AN APPEAL	
	405.07 - NOTIFICATION OF THE PARTIES OF THE APPEAL	
	405.08 - TIME LIMIT FOR DECISIONS ON APPEALS	
	405.09 - APPEAL BOARD DECISIONS	
	405.10 - COSTS	
406	PENALTIES .....	203
	406.01 - GENERAL	
	406.02 - REPRIMAND	

	406.03 - YELLOW CARD	
	406.04 - DISQUALIFICATION	
	406.05 - TEMPORARY SUSPENSION	
	406.06 - PROLONGED SUSPENSION	
	406.07 - EXCLUSION	
407	PRIORITY OF THESE RULES .....	207
408	POWERBOAT PROTEST FORM .....	207
409	ARBITRATION.....	210

## GROUP 500

500	INTERNATIONAL SERIES AND CLASSES.....	213
	500.01 - DEFINITIONS	
	500.02 - INTERNATIONAL SERIES AND CLASSES	
	500.03 - RECOGNISED SERIES AND CLASSES	
	500.04 - ENTRY LEVEL RACING CLASSES	
	500.10 - FORMULA FUTURE RULES	
501	MEASUREMENT CERTIFICATE .....	235
502	INSPECTIONS.....	239
503	EQUIPMENT - PEOPLE ABOARD MOTORS.....	244
504	NOISE REDUCTIONS .....	248
505	ENGINE HOMOLOGATION .....	249
508	FUEL.....	254
509	REINFORCED COCKPITS.....	258
510	RACING INBOARDS (R).....	280
511	CLASSES .....	280
512	HULL .....	280
513	MACHINERY.....	281
514	FUEL.....	282
515	RACING INBOARD - HISTORIC (H.R.) - FORMULA R 1000.....	282
516	CLASSES .....	283

517	HULL .....	283
518	MACHINERY.....	284
519	FUEL.....	284
520	RACING OUTBOARDS (O).....	284
521	CLASSES .....	284
522	HULL .....	285
523	MACHINERY.....	291
524	FUEL.....	292
525	CLASS OSY 400 .....	292
527	HULL .....	292
528	MACHINERY.....	293
529	FUEL.....	295
530	SPORT INBOARDS (E).....	295
531	CLASSES.....	296
532	HULL .....	296
533	MACHINERY.....	297
534	FUEL.....	301
540	SPORT OUTBOARDS (S).....	301
541	CLASSES .....	301
542	HULL .....	303
543	MACHINERY.....	304
544	FUEL.....	309
550	MONOHULL OUTBOARDS (T).....	309
551	CLASSES .....	309
553	MACHINERY.....	312



554	FUEL.....	316
560	INFLATABLE BOATS (P) .....	316
560	GENERAL .....	317
561	CLASSES/HULLS .....	324
562	MACHINERY.....	332
563.1	SURF DISCIPLINE .....	337
563.2	CIRCUIT DISCIPLINE .....	345
563.3	LONGHAUL DISCIPLINE.....	351
564.1	P.750 (S) STANDARD CLASS : SOLE MODIFICATIONS ALLOWED	
353		
564.2	FOR (BP) BLUE PRINT CLASS .....	357
564.3	P750 (M) MODIFIED CLASS .....	358
564.4	TECHNICAL SPECIFICATIONS .....	360
565	RIGID INFLATABLE BOATS (PR) (PF).....	369
566	CLASSES .....	369
567	HULL (PR CLASSES ONLY) .....	370
568	MACHINERY.....	374
569	FUEL.....	377
570	BOATS WITH DIESEL MOTORS (D) .....	377
571	CLASSES .....	377
572	HULL .....	378
573	MACHINERY.....	378
574	FUEL.....	379
580	TURBO JETS AND ROCKET PROPELLED BOATS (TR).....	379
581	CLASSES .....	379
582	HULL .....	380

583	MACHINERY.....	381
584	FUEL.....	381
590	BOATS WITH AERIAL PROPELLER (A).....	381
591	CLASSES .....	381
592	HULL .....	382
593	MACHINERY.....	382
594	FUEL.....	383
595	ELECTRIC POWERED BOATS (E).....	383
596	CLASSES .....	383
597	HULL .....	383
598	MACHINERY.....	384
599	ELECTRIC BOAT SAFETY RULES .....	386

500 INTERNATIONAL SERIES AND CLASSES

SERIES	SECTION	CLASSES	HULL	MACHINERY	FUEL
R	510	511	512	513	514
HR	515	516	517	518	519
O	520	521	522	523	524
OSY	525	526	527	528	529
E	530	531	532	533	534
S	540	541	542	543	544
T	550	551	552	553	554
P	560	561	562	563	564
PH	565	566	567	568	569
D	570	571	572	573	574
TR	580	581	582	583	584
A	590	591	592	593	594
EL	595	596	597	598	...

**GROUP 600**

600	RECORDS AND PERFORMANCES.....	388
	600.01 - GENERAL	
601	CLASSES ELIGIBLE FOR RECORDS.....	389
	601.01 - QUALIFICATION	
602	DEFINITION OF UNITS.....	390
	602.01 - TIME, DISTANCE AND SPEEDS	
	602.02 - STATUTE MILE, NAUTICAL MILE AND KILOMETRE	
604	BASES.....	391
605	CALCULATION OF SPEED .....	393
606	MARGIN REQUIRED .....	394
607	MOTORS.....	394
608	REQUEST TO ORGANISE .....	395
609	OFFICIALS .....	396
610	SPEED RECORDS.....	397
611	DISTANCE RECORDS .....	398
612	HOURLY RECORDS .....	399
613	WORLD COMPETITION RECORDS .....	402
614	PERFORMANCE CERTIFICATES.....	402
615	HOMOLOGATION OF RECORDS .....	403

**GROUP 700**

700	ENVIRONMENT .....	406
701	NOISE LEVEL .....	406
702	EMISSIONS.....	406
703	RE-FUELLING.....	406
704	ENVIRONMENTAL CARE IN RACE AREAS .....	406

**GROUP 800**

800	CUPS AND TROPHIES .....	408
801	ALFRED BUYSSE TROPHY .....	408
802	JOHN WARD TROPHY .....	409
803	BOUCQUEY TROPHY .....	410
804	DIETER KONIG MEMORIAL .....	410
805	JOHN HILL MEMORIAL .....	410

**GROUP 900**

900	U.I.M. RULES FOR RIVER MARATHON RACING .....	411
	900.01 - GENERAL	
	900.02 - APPLICABLE RULES	
	900.03 - RACE COURSE	
	900.04 - CREW	
	900.05 - EQUIPMENT	
	900.06 - TECHNICAL SAFETY REGULATIONS	
	900.07 - INSPECTION PROCEDURES	
	900.08 - GENERAL RACING RULES	
	900.09 - FLAG SIGNALS	
	900.10 - STARTING	
	900.11 - RACE IN PROGRESS RULES	
	900.12 - FINISHING RULES	
	900.13 - SUPPORT BOATS	
	900.14 - RACE OFFICIALS	
	900.15 - INTERNATIONAL RACING CLASSES	
901	RULES AND CODE OF PRACTISE FOR JETSPRINT RACING ....	438
	1. GENERAL RULES	
	2. BOAT AND SAFETY EQUIPMENT	
	3. ROLL CAGE SPECIFICATIONS	
	4. INTERNATIONAL JET SPRINT CLASSES	
	5. TESTING PROCEDURES	
	6. SPORTSMANSHIP AND COMPETITOR CODE OF CONDUCT	
	7. EVENT RULES	
902	NEW RULES FOR CIRCUIT ENDURANCE CHAMPIONSHIPS.....	476
903	GRAND PRIX HYDROPLANE CLASS .....	490

904	INBOARD RACING DISPLACEMENT CLASS RULES.....	497
905	HYDRO SPRINT RULES.....	501
	U.I.M. HYDRO SPRINT RULES.....	505
	U.I.M. FORMULA 1 WORLD CHAMPIONSHIP.....	549
	U.I.M. F2 WORLD AND CONTINENTAL CHAMPIONSHIPS.....	584
	U.I.M. FORMULA 3 WORLD CHAMPIONSHIP.....	611
	U.I.M. FORMULA 500 WORLD CHAMPIONSHIP.....	612
	U.I.M. FORMULA 4 WORLD CHAMPIONSHIP.....	621
	U.I.M. FORMULA 1000 INTERNATIONAL.....	633
	GENERAL FOR ALL FORMULAE RACES MATCH RACE RULES.....	639
	GENERAL FOR ALL FORMULAE RACES CODE OF PRACTICE FOR SAFETY.....	643



**UNION INTERNATIONALE  
MOTONAUTIQUE**

# **CODE OF ETHICS**

2010

## **1. Preamble**

The U.I.M. is committed to the highest standards of conduct in sport administration and competition. To meet this commitment, the U.I.M. has developed a Code of Ethics to express the core values of both the organisation and the sport of Powerboating. Such values and ethics underpin the U.I.M.'s policies, procedures and rules. Observance of the code is vital to the integrity of Powerboating. The U.I.M. Code of Ethics is inspired to the ethical principles of the Olympic Movement of which the U.I.M. is member.

The U.I.M. Code of Ethics comprises five pillars. It imposes obligations in terms of respect and responsibility to competitors, teams, promoters, officials and all other U.I.M. accredited persons.

### **The ethical pillars of the U.I.M.**

#### **1.1 Equality**

Discrimination and harassment against others on grounds of race, disability, marital status, sex, sexuality, age, political or religious conviction are not condoned in Powerboating.

All forms of harassment, be they physical, mental, professional or sexual, are strictly prohibited.

Powerboating promotes the inclusion of men and women equally.

#### **1.2 Fair Play**

Fair play is the guiding principle in the sport of Powerboating. It is expected that all persons taking part in Powerboating shall behave with fairness and honesty.

All persons shall operate within and abide by the rules of the sport.

All doping practices at all levels are strictly prohibited. The provisions against doping in Anti-Doping Code shall be scrupulously observed. Powerboating is committed to be a drug free sport.

### **1.3 Respect**

Powerboating shall be characterised by mutual respect and self-responsibility. All persons involved in powerboating shall be treated with dignity.

The contribution that people make to the sport shall be recognised.

In pursuing the sport's goals, the governance of Powerboating shall be mindful of the physical and psychological well-being of its members.

Violence and abusive behaviour are not tolerated.

### **1.4 Integrity**

All persons subject to this Code shall use due care and diligence in fulfilling their roles for, and on behalf of, the U.I.M. or Powerboating in general.

Decisions by the U.I.M. will be made in accordance with established procedures, objectively, fairly and with honesty and integrity.

Conflicts of interest must be avoided.

### **1.5 Environment**

The U.I.M. is committed to raise environmental performance of power boating and make our sport a vector of environmental protection and sustainable development.

U.I.M. looks to youth to breed a future for sportsmanship and safety while nurturing a passion and respect for water and its environment.

The U.I.M. will promote the optimal use of resources and materials, efficient logistics and transport, reduction of polluting discharges to water and emissions to air.



## 2. Conduct Regulations

This Code applies to the following “Involved Parties”: competitors, teams, promoters, officials and all other U.I.M. accredited persons.

### a) Basic rules

All involved Parties shall show commitment to an ethical attitude while fulfilling their task. They shall pledge to behave in accordance with the ethical pillars of the U.I.M.

U.I.M. Officials may not abuse their position as part of their function in any way, especially to take advantage of their function for private aims or gains.

### b) Representational duties

U.I.M. Officials shall represent U.I.M. honestly, respectably and with integrity.

### c) Conduct towards government and private organizations

In dealings with government institutions, national and international organizations, associations and groupings, “Involved Parties” shall, in addition to observing the basic rules of art. a, remain politically neutral, in accordance with the principles and objectives of U.I.M. and act in a manner compatible with their function and integrity.

### d) Ban on discrimination

“Involved Parties” may not act in a discriminatory manner, especially with regard to ethnicity, race, culture, politics, religion, gender or language.

### e) Eligibility and dismissal

Only those persons who demonstrate a high degree of ethics and integrity and pledge to observe the provisions of this Code without reservation are eligible to serve as U.I.M. officials. Any U.I.M. officials

who do not comply with these conditions are either no longer eligible or shall be removed from office.

f) Conflicts of interest

“Involved Parties” may not perform their tasks in cases with an existing or potential conflict of interest.

“Involved Parties”, particularly U.I.M. officials, shall avoid any situation that could lead to conflicts of interest. Conflicts of interest arise if there are private or personal interests that detract from the ability to carry out obligations as “Involved Parties”, particularly U.I.M. officials, with integrity in an independent and purposeful manner.

g) Protection of personal rights

During the course of their activities, “Involved Parties” shall ensure that the personal rights of those persons whom they contact and with whom they deal are protected, respected and safeguarded.

h) Loyalty and confidentiality

While performing their duties, officials shall remain loyal to U.I.M. Depending on their function, any information divulged to officials during the course of their duties shall be treated as confidential. Any information or opinions shall be passed on in accordance with the principles and objectives of U.I.M.

i) Accepting and giving gifts

“Involved Parties” are not permitted to accept gifts and other benefits that exceed the average relative value of local cultural customs from third parties.

Accepting gifts of cash in any amount or form is prohibited.

While performing their duties, officials may give gifts and other benefits in accordance with the average relative value of local cultural customs to third parties, provided no dishonest advantages are gained and there is no conflict of interest.

#### j) Bribery

“Involved Parties” may not accept bribes, in other words, any gifts or other advantages that are offered, promised or sent to them to incite breach of duty or dishonest conduct.

“Involved Parties” are forbidden from bribing third parties or from urging or inciting others to do so in order to gain an advantage for them or a third party.

#### k) Betting

“Involved Parties” are forbidden from taking part, either directly or indirectly, in illegal betting or gambling connected with powerboat races.

### **3. Procedural regulations**

#### a) Basic principle

Violations of the rules of this Code shall be sanctioned.

#### b) Judging body

The U.I.M. Executive Committee shall judge cases that are not compliant with the U.I.M. Code of Ethic.

#### c) Disciplinary measures

The U.I.M. Executive Committee will decide disciplinary measures.

#### d) Hearings

The hearings of U.I.M. Executive Committee for proceedings related to ethics matters are deemed to be valid if the majority of the U.I.M. Executive Committee members are present.

#### e) Confidentiality

The members of the judicial body shall ensure that everything disclosed to them during the course of their duty remains confidential (facts of the case, contents of the deliberations and decisions taken). Only the contents of those decisions already notified to the addressees may be made public.

### **4. Enforcement**

The conduct and procedural regulations of this Code are adopted by the U.I.M. General Assembly of October 25<sup>th</sup>, 2009 and come into force on January 1, 2010.



**UNION INTERNATIONALE**

**MOTONAUTIQUE**

**ANTI-DOPING  
RULES**

2010

# TABLE OF CONTENTS

INTRODUCTION .....	35
PREFACE .....	35
<i>Fundamental Rationale for the Code     and U.I.M.'s Anti-Doping Rules</i> .....	35
<i>Scope</i> .....	36
ARTICLE 1    DEFINITION OF DOPING .....	38
ARTICLE 2    ANTI-DOPING RULE VIOLATIONS .....	38
ARTICLE 3    PROOF OF DOPING.....	43
ARTICLE 4    THE PROHIBITED LIST.....	46
ARTICLE 5 <i>TESTING</i> .....	50
ARTICLE 6    ANALYSIS OF <i>SAMPLES</i> .....	54
ARTICLE 7    RESULTS MANAGEMENT .....	56
ARTICLE 8    RIGHT TO A FAIR HEARING .....	63
ARTICLE 9 <i>AUTOMATIC DISQUALIFICATION     OF INDIVIDUAL RESULTS</i> .....	66
ARTICLE 10   SANCTIONS ON INDIVIDUALS .....	66
ARTICLE 11 <i>INTENTIONALLY LEFT BLANK</i> .....	89
ARTICLE 12   SANCTIONS AND COSTS ASSESSED AGAINST <i>NATIONAL ASSOCIATIONS</i> .....	90
ARTICLE 13   APPEALS .....	91
ARTICLE 14 <i>NATIONAL ASSOCIATIONS</i> INCORPORATION OF U.I.M. RULES, REPORTING AND RECOGNITION...95	
ARTICLE 15   RECOGNITION OF DECISIONS BY OTHER ORGANISATIONS .....	98

ARTICLE 16	STATUTE OF LIMITATIONS.....	98
ARTICLE 17	U.I.M. COMPLIANCE REPORTS TO <i>WADA</i> .....	98
ARTICLE 18	AMENDMENT AND INTERPRETATION OF ANTI-DOPING RULES .....	99

# U.I.M. ANTI-DOPING RULES

## INTRODUCTION

### Preface

At the U.I.M. General Assembly held on the 2<sup>nd</sup> November 2008 in the Gold Coast, Australia, the U.I.M. accepted the revised (2009) U.I.M. Anti-Doping Rules based on the World Anti-Doping *Code* (the “*Code*“) approved in Madrid, Spain, in November 2007. These Anti-Doping Rules are adopted and implemented in conformance with the U.I.M.’s responsibilities under the *Code*, and are in furtherance of the U.I.M.’s continuing efforts to eradicate doping in the sport of Powerboating.

Anti-Doping Rules, like *Competition* rules, are sport rules governing the conditions under which sport is played. *Drivers* and other *Persons* accept these rules as a condition of participation and shall be bound by them. These sport-specific rules and procedures, aimed at enforcing anti-doping principles in a global and harmonized manner, are distinct in nature and, therefore, not intended to be subject to, or limited by any national requirements and legal standards applicable to criminal proceedings or employment matters. When reviewing the facts and the law of a given case, all courts, arbitral tribunals and other adjudicating bodies should be aware of and respect the distinct nature of the anti-doping rules in the *Code* and the fact that these rules represent the consensus of a broad spectrum of stakeholders around the world with an interest in fair sport.

### Fundamental Rationale for the Code and the U.I.M.’s Anti-Doping Rules

Anti-doping programs seek to preserve what is intrinsically valuable about sport. This intrinsic value is often referred to as “the spirit of sport”; it is the essence of Olympism; it is how we play true. The spirit of sport is the celebration of the human spirit, body and mind, and is characterized by the following values:



- Ethics, fair play and honesty
- Health
- Excellence in performance
- Character and education
- Fun and joy
- Teamwork
- Dedication and commitment
- Respect for rules and laws
- Respect for self and other participants
- Courage
- Community and solidarity

Doping is fundamentally contrary to the spirit of sport.

## Scope

These Anti-Doping Rules shall apply to the U.I.M., each *National Association* of the U.I.M., and each *Participant* in the activities of the U.I.M. or any of its *National Associations* by virtue of the *Participant's* membership, accreditation, or participation in the U.I.M., its *National Associations*, or their activities or *Events*. Any *Person* who is not a member of a National Association and who fulfills the requirements to be part of the U.I.M. Registered Testing Pool, must become a member of the *Person's National Association*, and must make himself or herself available for *Testing*, at least six months before participating in *International Events* or events of his/her *National Association*.

To be eligible for participation in U.I.M. events, a *Driver* must have a Powerboat Racing licence issued by his or her National Association. The Powerboat Racing licence will only be issued to *Drivers* who have personally signed the Appendix 2 consent form, in the actual form approved by the U.I.M. Executive. All forms from under-age applicants must be counter-signed by their legal guardians.

The National Association must guarantee that all *Drivers* registered for a Powerboat Racing Licence accept the Rules of the U.I.M., concerning these U.I.M. Anti-Doping Rules.

It is the responsibility of each *National Association* to ensure that all national-level *Testing* on the *National Association's Drivers* complies with these Anti-Doping Rules. In some countries, the *National Association* itself will be conducting the *Doping Control* described in these Anti-Doping Rules. In other countries, many of the *Doping Control* responsibilities of the *National Association* have been delegated or assigned by statute or agreement to a *National Anti-Doping Organization*. In those countries, references in these Anti-Doping Rules to the *National Association* shall apply, as appropriate, to the *National Anti-Doping Organization*.

These Anti-Doping Rules shall apply to all *Doping Controls* over which the U.I.M. and its *National Associations* have jurisdiction.

## ARTICLE 1 DEFINITION OF DOPING

Doping is defined as the occurrence of one or more of the anti-doping rule violations set forth in Article 2.1 through Article 2.8 of these Anti-Doping Rules.

## ARTICLE 2 ANTI-DOPING RULE VIOLATIONS

*Drivers* and other *Persons* shall be responsible for knowing what constitutes an anti-doping rule violation and the substances and methods which have been included on the *Prohibited List*.

The following constitute anti-doping rule violations:

*[Comment to Article 2: The purpose of Article 2 is to specify the circumstances and conduct which constitute violations of anti-doping rules. Hearings in doping cases will proceed based on the assertion that one or more of these specific rules has been violated.]*

### **2.1 The presence of a Prohibited Substance or its Metabolites or Markers in a Driver's Sample**

**2.1.1** It is each *Drivers* personal duty to ensure that no *Prohibited Substance* enters his or her body. *Drivers* are responsible for any *Prohibited Substance* or its *Metabolites* or *Markers* found to be present in their *Samples*. Accordingly, it is not necessary that intent, fault, negligence or knowing *Use* on the *Driver's* part be demonstrated in order to establish an anti-doping violation under Article 2.1.

*[Comment to Article 2.1.1: For purposes of anti-doping violations involving the presence of a Prohibited Substance (or its Metabolites or Markers), U.I.M.'s Anti-Doping Rules adopt the rule of strict liability which was found in the Olympic Movement Anti-Doping Code ("OMADC") and the vast majority of pre-Code anti-doping rules. Under the strict liability principle, a Driver is responsible, and an anti-doping rule violation occurs, whenever a Prohibited Substance is found in a Driver's Sample. The violation occurs whether or not the Driver intentionally or unintentionally used a Prohibited Substance or was negligent or otherwise at fault. If the positive Sample came from an In-Competition test, then the results*

*of that Competition are automatically invalidated (Article 9 (Automatic Disqualification of Individual Results)). However, the Driver then has the possibility to avoid or reduce sanctions if the Driver can demonstrate that he or she was not at fault or significant fault (Article 10.5 (Elimination or Reduction of Period of Ineligibility Based on Exceptional Circumstances)) or in certain circumstances did not intend to enhance his or her sport performance (Article 10.4 (Elimination or Reduction of the Period of Ineligibility for Specified Substances under Specific Circumstances)).*

*The strict liability rule for the finding of a Prohibited Substance in a Driver's Sample, with a possibility that sanctions may be modified based on specified criteria, provides a reasonable balance between effective anti-doping enforcement for the benefit of all "clean" Drivers and fairness in the exceptional circumstance where a Prohibited Substance entered a Driver's system through No Fault or Negligence or No Significant Fault or Negligence on the Driver's part. It is important to emphasize that while the determination of whether the anti-doping rule has been violated is based on strict liability, the imposition of a fixed period of Ineligibility is not automatic. The strict liability principle set forth in International Federation's Anti-Doping Rules has been consistently upheld in the decisions of CAS.]*

**2.1.2** Sufficient proof of an anti-doping rule violation under Article 2.1 is established by either of the following: presence of a *Prohibited Substance* or its *Metabolites* or *Markers* in the *Driver's A Sample* where the *Driver* waives analysis of the *B Sample* and the *B Sample* is not analyzed; or, where the *Driver's B Sample* is analyzed and the analysis of the *Driver's B Sample* confirms the presence of the *Prohibited Substance* or its *Metabolites* or *Markers* found in the *Driver's A Sample*.

*[Comment to Article 2.1.2: The U.I.M. may in its discretion choose to have the B Sample analyzed even if the Driver does not request the analysis of the B Sample.]*

**2.1.3** Excepting those substances for which a quantitative threshold is specifically identified in the *Prohibited List*, the presence of any quantity of a *Prohibited Substance* or its *Metabolites* or *Markers* in a *Driver's Sample* shall constitute an anti-doping rule violation.

**2.1.4** As an exception to the general rule of Article 2.1, the *Prohibited List* or *International Standards* may establish special criteria for the evaluation of *Prohibited Substances* that can also be produced endogenously.

## **2.2 Use or Attempted Use by a Driver of a Prohibited Substance or a Prohibited Method**

*[Comment to Article 2.2: As noted in Article 3 (Proof of Doping), it has always been the case that Use or Attempted Use of a Prohibited Substance or Prohibited Method may be established by any reliable means. Unlike the proof required to establish an anti-doping rule violation under Article 2.1, Use or Attempted Use may also be established by other reliable means such as admissions by the Driver, witness statements, documentary evidence, conclusions drawn from longitudinal profiling, or other analytical information which does not otherwise satisfy all the requirements to establish "Presence" of a Prohibited Substance under Article 2.1. For example, Use may be established based upon reliable analytical data from the analysis of an A Sample (without confirmation from an analysis of a B Sample) or from the analysis of a B Sample alone where the U.I.M. provides a satisfactory explanation for the lack of confirmation in the other Sample.]*

**2.2.1** It is each *Driver's* personal duty to ensure that no *Prohibited Substance* enters his or her body. Accordingly, it is not necessary that intent, fault, negligence or knowing *Use* on the *Driver's* part be demonstrated in order to establish an anti-doping rule violation for *Use* of a *Prohibited Substance* or a *Prohibited Method*.

**2.2.2** The success or failure of the *Use* of a *Prohibited Substance* or *Prohibited Method* is not material. It is sufficient that the *Prohibited Substance* or *Prohibited Method* was *Used* or *Attempted* to be *Used* for an anti-doping rule violation to be committed.

*[Comment to Article 2.2.2: Demonstrating the "Attempted Use" of a Prohibited Substance requires proof of intent on the Driver's part. The fact that intent may be required to prove this particular anti-doping rule violation does not undermine the strict liability principle established for*

*violations of Article 2.1 and violations of Article 2.2 in respect of Use of a Prohibited Substance or Prohibited Method.*

*A Driver's "Use" of a Prohibited Substance constitutes an anti-doping rule violation unless such substance is not prohibited Out-of-Competition and the Driver's Use takes place Out-of-Competition. (However, the presence of a Prohibited Substance or its Metabolites or Markers in a Sample collected In-Competition will be a violation of Article 2.1 (Presence of a Prohibited Substance or its Metabolites or Markers) regardless of when that substance might have been administered.)]*

**2.3 Refusing or failing without compelling justification to submit to Sample collection after notification as authorized in these Anti-Doping Rules, or otherwise evading Sample collection.**

*[Comment to Article 2.3: Failure or refusal to submit to Sample collection after notification was prohibited in almost all pre-Code anti-doping rules. This Article expands the typical pre-Code rule to include "otherwise evading Sample collection" as prohibited conduct. Thus, for example, it would be an anti-doping rule violation if it were established that a Driver was hiding from a Doping Control official to evade notification or Testing. A violation of "refusing or failing to submit to Sample collection" may be based on either intentional or negligent conduct of the Driver, while "evading" Sample collection contemplates intentional conduct by the Driver.]*

**2.4 Violation of applicable requirements regarding Driver availability for Out-of-Competition Testing set out in the International Standard for Testing, including failure to file whereabouts information** in accordance with Article 11.3 of the *International Standard for Testing* (a "**Filing Failure**") and failure to be available for Testing at the declared whereabouts in accordance with Article 11.4 of the *International Standard for Testing* (a "**Missed Test**"). Any combination of three Missed Tests and/or Filing Failures committed within an eighteen-month period, as declared by the U.I.M. or any other Anti-Doping Organization with jurisdiction over a Driver, shall constitute an anti-doping rule violation.

*[Comment to Article 2.4: Separate whereabouts filing failures and missed tests declared under the rules of the U.I.M. or any other Anti-*

*Doping Organization with authority to declare whereabouts filing failures and missed tests in accordance with the International Standard for Testing shall be combined in applying this Article. In appropriate circumstances, missed tests or filing failures may also constitute an anti-doping rule violation under Article 2.3 or Article 2.5.]*

### **2.5 Tampering or Attempted Tampering with any part of Doping Control.**

*[Comment to Article 2.5: This Article prohibits conduct which subverts the Doping Control process but which would not otherwise be included in the definition of Prohibited Methods. For example, altering identification numbers on a Doping Control form during Testing, breaking the B Bottle at the time of B Sample analysis or providing fraudulent information to the U.I.M.]*

### **2.6 Possession of Prohibited Substances and Methods**

**2.6.1** *Possession by a Driver In-Competition of any Prohibited Method or any Prohibited Substance, or Possession by a Driver Out-of-Competition of any Prohibited Method or any Prohibited Substance which is prohibited in Out-of-Competition Testing unless the Driver establishes that the Possession is pursuant to a therapeutic use exemption (“TUE”) granted in accordance with Article 4.4 (Therapeutic Use) or other acceptable justification.*

**2.6.2** *Possession by Driver Support Personnel In-Competition of any Prohibited Method or any Prohibited Substance, or Possession by Driver Support Personnel Out-of-Competition of any Prohibited Method or any Prohibited Substance which is prohibited Out-of-Competition, in connection with a Driver, Competition or training, unless the Driver Support Personnel establishes that the Possession is pursuant to a TUE granted to a Driver in accordance with Article 4.4 (Therapeutic Use) or other acceptable justification.*

*[Comment to Article 2.6.1 and 2.6.2: Acceptable justification would not include, for example, buying or possessing a Prohibited Substance for purposes of giving it to a friend or relative, except under justifiable*

*medical circumstances where that Person had a physician's prescription, e.g., buying Insulin for a diabetic child.]*

*[Comment to Article 2.6.2: Acceptable justification would include, for example, a team doctor carrying Prohibited Substances for dealing with acute and emergency situations.]*

### **2.7 Trafficking or Attempted Trafficking in any Prohibited Substance or Prohibited Method.**

**2.8 Administration or Attempted administration to any Driver In-Competition of any Prohibited Method or Prohibited Substance, or administration or Attempted administration to any Driver Out-of-Competition of any Prohibited Method or any Prohibited Substance that is prohibited Out-of-Competition, or assisting, encouraging, aiding, abetting, covering up or any other type of complicity involving an anti-doping rule violation or any Attempted anti-doping rule violation.**

*[Comment to Article 2: The Code does not make it an anti-doping rule violation for a Driver or other Person to work or associate with Driver Support Personnel who are serving a period of Ineligibility. However, U.I.M. may adopt its own specific policy which prohibits such conduct.]*

## **ARTICLE 3 PROOF OF DOPING**

### **3.1 Burdens and Standards of Proof**

*U.I.M. and its National Associations shall have the burden of establishing that an anti-doping rule violation has occurred. The standard of proof shall be whether U.I.M. or its National Association has established an anti-doping rule violation to the comfortable satisfaction of the hearing panel bearing in mind the seriousness of the allegation which is made. This standard of proof in all cases is greater than a mere balance of probability but less than proof beyond a reasonable doubt. Where these Rules place the burden of proof upon the Driver or other Person alleged to have committed an anti-doping rule violation to rebut a presumption or establish specified facts or circumstances, the standard of proof shall be by a balance*



of probability, except as provided in Articles 10.4 and 10.6, where the *Driver* must satisfy a higher burden of proof.

*[Comment to Article 3.1: This standard of proof required to be met by U.I.M. or its National Association is comparable to the standard which is applied in most countries to cases involving professional misconduct. It has also been widely applied by courts and hearing panels in doping cases. See, for example, the CAS decision in N., J., Y., W. v. FINA, CAS 98/208, 22 December 1998.]*

### **3.2 Methods of Establishing Facts and Presumptions**

Facts related to anti-doping rule violations may be established by any reliable means, including admissions. The following rules of proof shall be applicable in doping cases:

*[Comment to Article 3.2: For example, U.I.M. or its National Association may establish an anti-doping rule violation under Article 2.2 (Use of a Prohibited Substance or Prohibited Method) based on the Driver's admissions, the credible testimony of third Persons, reliable documentary evidence, reliable analytical data from either an A or B Sample as provided in the Comments to Article 2.2, or conclusions drawn from the profile of a series of the Driver's blood or urine Samples.]*

**3.2.1** WADA-accredited laboratories are presumed to have conducted *Sample* analysis and custodial procedures in accordance with the *International Standard* for Laboratories. The *Driver* or other *Person* may rebut this presumption by establishing that a departure from the *International Standard* occurred which could reasonably have caused the *Adverse Analytical Finding*.

If the *Driver* or other *Person* rebuts the preceding presumption by showing that a departure from the *International Standard* occurred which could reasonably have caused the *Adverse Analytical Finding*, then U.I.M. or its *National Association* shall have the burden to establish that such departure did not cause the *Adverse Analytical Finding*.

*[Comment to Article 3.2.1: The burden is on the Driver or other Person to establish, by a balance of probability, a departure from the*

*International Standard that could reasonably have caused the Adverse Analytical Finding. If the Driver or other Person does so, the burden shifts to U.I.M. or its National Association to prove to the comfortable satisfaction of the hearing panel that the departure did not cause the Adverse Analytical Finding.]*

**3.2.2** Departures from any other *International Standard* or other anti-doping rule or policy which did not cause an *Adverse Analytical Finding* or other anti-doping rule violation shall not invalidate such results. If the *Driver* or other *Person* establishes that a departure from another *International Standard* or other anti-doping rule or policy which could reasonably have caused the *Adverse Analytical Finding* or other anti-doping rule violation occurred, then *U.I.M.* or its *National Association* shall have the burden to establish that such a departure did not cause the *Adverse Analytical Finding* or the factual basis for the anti-doping rule violation.

**3.2.3** The facts established by a decision of a court or professional disciplinary tribunal of competent jurisdiction which is not the subject of a pending appeal shall be irrebuttable evidence against the *Driver* or other *Person* to whom the decision pertained of those facts unless the *Driver* or other *Person* establishes that the decision violated principles of natural justice.

**3.2.4** The hearing panel in a hearing on an anti-doping rule violation may draw an inference adverse to the *Driver* or other *Person* who is asserted to have committed an anti-doping rule violation based on the *Driver's* or other *Person's* refusal, after a request made in a reasonable time in advance of the hearing, to appear at the hearing (either in person or telephonically as directed by the tribunal) and to answer questions either from the hearing panel or from the *Anti-Doping Organization* asserting the anti-doping rule violation.

*[Comment to Article 3.2.4: Drawing an adverse inference under these circumstances has been recognized in numerous CAS decisions.]*

## ARTICLE 4 THE PROHIBITED LIST

### 4.1 Incorporation of the *Prohibited List*

These Anti-Doping Rules incorporate the *Prohibited List* which is published and revised by WADA as described in Article 4.1 of the Code. U.I.M. will make the current *Prohibited List* available to each National Association, and each National Association shall ensure that the current *Prohibited List* is available to its members and constituents.

*[Comment to Article 4.1: The Prohibited List will be revised and published on an expedited basis whenever the need arises. However, for the sake of predictability, a new Prohibited List will be published every year whether or not changes have been made. The Prohibited List in force is available on WADA's website at [www.wada-ama.org](http://www.wada-ama.org). The Prohibited List is an integral part of the International Convention against Doping in Sport.]*

### 4.2 *Prohibited Substances and Prohibited Methods Identified on the Prohibited List*

#### 4.2.1 *Prohibited Substances and Prohibited Methods*

Unless provided otherwise in the *Prohibited List* and/or a revision, the *Prohibited List* and revisions shall go into effect under these Anti-Doping Rules three months after publication of the *Prohibited List* by WADA without requiring any further action by U.I.M. As described in Article 4.2 of the Code, U.I.M. may request that WADA expand the *Prohibited List* for the sport of Powerboating. U.I.M. may also upon the recommendation of its Anti-Doping Commission request that WADA include additional substances or methods, which have the potential for abuse in the sport of Powerboating, in the monitoring program described in Article 4.5 of the Code. As provided in the Code, WADA shall make the final decision on such requests by U.I.M.

*[Comment to Article 4.2.1: There will be one Prohibited List. The substances which are prohibited at all times would include masking agents and those substances which, when used in training, may have long term performance enhancing effects such as anabolics. All*

*substances and methods on the Prohibited List are prohibited In-Competition. Out-of-Competition Use (Article 2.2) of a substance which is only prohibited In-Competition is not an anti-doping rule violation unless an Adverse Analytical Finding for the substance or its Metabolites is reported for a Sample collected In-Competition (Article 2.1).*

*There will be only one document called the "Prohibited List." WADA may add additional substances or methods to the Prohibited List for particular sports (e.g. the inclusion of beta-blockers for shooting) but this will also be reflected on the single Prohibited List. A particular sport is not permitted to seek exemption from the basic list of Prohibited Substances (e.g. eliminating anabolics from the Prohibited List for "mind sports"). The premise of this decision is that there are certain basic doping agents which anyone who chooses to call himself or herself a Driver should not take.]*

#### **4.2.2 Specified Substances**

For purposes of the application of Article 10 (Sanctions on Individuals), all *Prohibited Substances* shall be "Specified Substances" except (a) substances in the classes of anabolic agents and hormones; and (b) those stimulants and hormone antagonists and modulators so identified on the *Prohibited List*. *Prohibited Methods* shall not be Specified Substances.

#### **4.2.3 New Classes of Prohibited Substances**

In the event WADA expands the *Prohibited List* by adding a new class of *Prohibited Substances* in accordance with Article 4.1 of the *Code*, WADA's Executive Committee shall determine whether any or all *Prohibited Substances* within the new class of *Prohibited Substances* shall be considered Specified Substances under Article 4.2.2.

### **4.3 Criteria for Including Substances and Methods on the Prohibited List**

As provided in Article 4.3.3 of the *Code*, WADA's determination of the *Prohibited Substances* and *Prohibited Methods* that will be included on the *Prohibited List* and the classification of substances into categories on the *Prohibited List* is final and shall not be subject

to challenge by a Driver or other *Person* based on an argument that the substance or method was not a masking agent or did not have the potential to enhance performance, represent a health risk or violate the spirit of sport.

*[Comment to Article 4.3: The question of whether a substance meets the criteria in Article 4.3 (Criteria for Including Substances and Methods on the Prohibited List) in a particular case cannot be raised as a defense to an anti-doping rule violation. For example, it cannot be argued that the Prohibited Substance detected would not have been performance enhancing in that particular sport. Rather, doping occurs when a substance on the Prohibited List is found in a Driver's Sample. Similarly, it cannot be argued that a substance listed in the class of anabolic agents does not belong in that class.]*

#### **4.4 Therapeutic Use**

**4.4.1** *Drivers* with a documented medical condition requiring the use of a *Prohibited Substance* or a *Prohibited Method* must first obtain a TUE. The presence of a *Prohibited Substance* or its *Metabolites* or *Markers* (Article 2.1), *Use* or *Attempted Use* of a *Prohibited Substance* or a *Prohibited Method* (Article 2.2), *Possession* of *Prohibited Substances* or *Prohibited Methods* (Article 2.6) or administration of a *Prohibited Substance* or *Prohibited Method* (Article 2.8) consistent with the provisions of an applicable TUE issued pursuant to the *International Standard* for Therapeutic Use Exemptions shall not be considered an anti-doping rule violation.

**4.4.2** Subject to Article 4.4.3, *Drivers* included by U.I.M. in its *Registered Testing Pool* and other *Drivers* participating in any *International Event* must obtain a TUE from U.I.M. (regardless of whether the *Driver* previously has received a TUE at the national level). The application for a TUE must be made as soon as possible (in the case of a *Driver* in the *Registered Testing Pool*, this would be when he/she is first notified of his/her inclusion in the pool) and in any event (save in emergency situations) no later than 21 days before the *Driver's* participation in the *Event*.

**4.4.3** The only exception to Article 4.4.2 is that, in accordance with Article 7.13 of the *International Standard for Therapeutic Use Exemptions*, *Drivers* not in U.I.M.'s *Registered Testing Pool* who inhale Glucocorticosteroids and/or formoterol, salbutamol, salmeterol or terbutaline to treat asthma or one of its clinical variants do not need a TUE in advance of participating in an *International Event* unless so specified by *U.I.M.* Instead, if necessary, any such *Driver* may apply for a Retroactive TUE after the *Event* in accordance with Article 7.13 of the *International Standard for Therapeutic Use Exemptions* and Article 7.1.3 of these Anti-Doping Rules.

**4.4.4** TUE's granted by *U.I.M.* shall be reported to the *Driver's National Association* and to *WADA*. Other *Drivers* subject to *Testing* who need to use a *Prohibited Substance* or a *Prohibited Method* for therapeutic reasons must obtain a TUE from their *National Anti-Doping Organization* or other body designated by their *National Association*, as required under the rules of the *National Anti-Doping Organization/other body*. *National Associations* shall promptly report any such TUE's to *U.I.M.* and *WADA*.

**4.4.5** The U.I.M. Executive shall appoint a panel of physicians to consider requests for TUE's (the "**TUE Committee**"). Upon U.I.M.'s receipt of a TUE request, the Chair of the TUE Panel shall appoint one or more members of the TUE Panel (which may include the Chair) to consider such request. The TUE Committee member(s) so designated shall promptly evaluate such request in accordance with the *International Standard for Therapeutic Use Exemptions* and render a decision on such request, which shall be the final decision of U.I.M.

**4.4.6** *WADA*, at the request of a *Driver* or on its own initiation, may review the granting or denial of any TUE by *U.I.M.* If *WADA* determines that the granting or denial of a TUE did not comply with the *International Standard for Therapeutic Use Exemptions* in force at the time then *WADA* may reverse that decision. Decisions on TUE's are subject to further appeal as provided in Article 13.

## ARTICLE 5 TESTING

### 5.1 Authority to Test

All *Drivers* under the jurisdiction of a *National Association* shall be subject to *In-Competition Testing* by U.I.M., the *Driver's National Association*, and any other *Anti-Doping Organization* responsible for *Testing* at a *Competition* or *Event* in which they participate. All *Drivers* under the jurisdiction of a *National Association*, including *Drivers* serving a period of ineligibility or a *Provisional Suspension*, shall also be subject to *Out-of-Competition Testing* at any time or place, with or without advance notice, by U.I.M., WADA, the *Driver's National Association*, the *National Anti-Doping Organization* of any country where the *Driver* is present. *Target Testing* will be made a priority.

*[Comment to Article 5.1: Target Testing is specified because random Testing, or even weighted random Testing, does not ensure that all of the appropriate Drivers will be tested (e.g., world-class Drivers, Drivers whose performances have dramatically improved over a short period of time, Drivers whose coaches have had other Drivers test positive, etc.). Obviously, Target Testing must not be used for any purposes other than legitimate Doping Control. The Code makes it clear that Drivers have no right to expect that they will be tested only on a random basis. Similarly, it does not impose any reasonable suspicion or probable cause requirement for Target Testing]*

### 5.2 Responsibility for U.I.M. Testing

The U.I.M. shall be responsible for drawing up a test distribution plan for the sport of Powerboating in accordance with Article 4 of the *International Standard for Testing*, and for the implementation of that plan, including overseeing all *Testing* conducted by or on behalf of U.I.M. *Testing* may be conducted by members of the U.I.M. or by other qualified persons so authorized by U.I.M.

### 5.3 Testing Standards

*Testing* conducted by U.I.M. and its *National Associations* shall be in substantial conformity with the *International Standard for Testing* in force at the time of *Testing*.

**5.3.1** Blood or other non-urine *Samples* may be used to detect *Prohibited Substances* or *Prohibited Methods*, for screening procedure purposes, or for longitudinal biological profiling. If the *Sample* is collected for screening only, it will have no consequences for the *Driver* other than to identify him/her for a urine test under these anti-doping rules. In these circumstances, the U.I.M. may decide at its own discretion which parameters are to be measured in the screening *Sample* and what levels of those parameters will be used to indicate that a *Driver* should be selected for a urine test. If however, the *Sample* is collected for longitudinal biological profiling, it may be used for anti-doping purposes in accordance with Article 2.2 of the *Code*.

#### **5.4 Coordination of Testing**

U.I.M. and *National Associations* shall promptly report completed tests through the *WADA* clearinghouse to avoid unnecessary duplication in *Testing*.

#### **5.5 Driver Whereabouts Requirements**

**5.5.1** U.I.M. shall identify a *Registered Testing Pool* of those *Drivers* who are required to comply with the whereabouts requirements of the *International Standard for Testing*, and shall publish the criteria for *Drivers* to be included in this *Registered Testing Pool* as well as a list of the *Drivers* meeting those criteria for the period in question. U.I.M. shall review and update as necessary its criteria for including *Drivers* in its *Registered Testing Pool*, and shall revise the membership of its *Registered Testing Pool* from time to time as appropriate in accordance with the set criteria. Each *Driver* in the *Registered Testing Pool* (a) shall advise U.I.M. of his/her whereabouts on a quarterly basis, in the manner set out in Article 11.3 of the *International Standard for Testing*; (b) shall update that information as necessary, in accordance with Article 11.4.2 of the *International Standard for Testing*, so that it remains accurate and complete at all times; and (c) shall make him/herself available for *Testing* at such whereabouts, in accordance with Article 11.4 of the *International Standard for Testing*.



*[Comment to Article 5.5.1: The purpose of the U.I.M. Registered Testing Pool is to identify top-level International Drivers who the U.I.M. requires to provide whereabouts information to facilitate Out-of-Competition Testing by U.I.M. and other Anti-Doping Organizations with jurisdiction over the Drivers. U.I.M. will identify such Drivers in accordance with the requirements of Articles 4 and 11.2 of the International Standard for Testing.]*

*Examples for the criteria which could be used separately or in combination include:*

- All medalists / team members of (Team) medalists from the previous (one, two,...) world championships / continental championships / top 10 Drivers in each discipline or in World Ranking or World Cup.*
- Any Driver whose performance is better than or equal to the fiftieth best performances in the preceding competition year.*
- All Drivers who are members of the top 8 teams in the Team Ranking*

*Every National Association shall report to U.I.M. the performances, names and addresses of all Drivers whose performances fall within the Registered Testing Pool criteria established by U.I.M.*

**5.5.2** A Driver's failure to advise U.I.M. of his/her whereabouts shall be deemed a Filing Failure for purposes of Article 2.4 where the conditions of Article 11.3.5 of the *International Standard for Testing* are met.

**5.5.3** A Driver's failure to be available for Testing at his/her declared whereabouts shall be deemed a Missed Test for purposes of Article 2.4 where the conditions of Article 11.4.3 of the *International Standard for Testing* are met.

**5.5.4** Each *National Association* shall also assist its *National Anti-Doping Organization* in establishing a national level *Registered Testing Pool* of top level national *Drivers* to whom the whereabouts requirements of the *International Standard for Testing* shall also apply. Where those *Drivers* are also in the

U.I.M.'s *Registered Testing Pool*, the U.I.M. and the *National Anti-Doping Organization* will agree on which of them will take responsibility for receiving whereabouts filings from the *Driver* and sharing it with the other (and with other *Anti-Doping Organizations*) in accordance with Article 5.5.5.

**5.5.5** Whereabouts information provided pursuant to Articles 5.5.1 and 5.5.4 shall be shared with *WADA* and other *Anti-Doping Organizations* having jurisdiction to test a *Driver* in accordance with Articles 11.7.1(d) and 11.7.3(d) of the *International Standard for Testing*, including the strict condition that it be used only for *Doping Control* purposes.

## **5.6 Retirement and Return to Competition**

**5.6.1** A *Driver* who has been identified by U.I.M. for inclusion in U.I.M.'s *Registered Testing Pool* shall continue to be subject to these Anti-Doping Rules, including the obligation to comply with the whereabouts requirements of the *International Standard for Testing* unless and until the *Driver* gives written notice to U.I.M. that he or she has retired or until he or she no longer satisfies the criteria for inclusion in U.I.M.'s *Registered Testing Pool* and has been so informed by U.I.M.

**5.6.2** A *Driver* who has given notice of retirement to U.I.M. may not resume competing unless he or she notifies U.I.M. at least six months before he or she expects to return to competition and makes him/herself available for unannounced *Out-of-Competition Testing*, including complying with the whereabouts requirements of the *International Standard for Testing*, at any time during the period before actual return to competition.

**5.6.3** *National Associations/National Anti-Doping Organizations* may establish similar requirements for retirement and returning to competition for *Drivers* in the national *Registered Testing Pool*.

## **5.7 Selection of Drivers to be Tested**

**5.7.1** At *International Events*, the U.I.M. shall determine the number of finishing placement tests, random tests and target tests to be performed.

The following *Drivers* shall be tested for each *Competition* at an *International Event*.

Each *Driver* finishing in one of the top three placements in random disciplines in the *Competition*, plus one other *Driver* in the *Competition* selected at random.

**5.7.2** At *National Events*, each *National Association* shall determine the number of *Drivers* selected for *Testing* in each *Competition* and the procedures for selecting the *Drivers* for *Testing*.

**5.7.3** In addition to the selection procedures set forth in Articles 5.7.1 and 5.7.2 above, the U.I.M. at *International Events*, and the *National Association* at *National Events*, may also select *Drivers* or teams for *Target Testing* so long as such *Target Testing* is not used for any purpose other than legitimate *Doping Control* purposes.

**5.7.4** *Drivers* shall be selected for *Out-of-Competition Testing* by the U.I.M. and by *National Associations* through a process that substantially complies with the *International Standard for Testing* in force at the time of selection.

**5.8** *National Associations* and the organizing committees for *National Association Events* shall provide access to *Independent Observers* at *Events* as directed by U.I.M.

## **ARTICLE 6 ANALYSIS OF SAMPLES**

*Doping Control Samples* collected under these Anti-Doping Rules shall be analyzed in accordance with the following principles:

### **6.1 Use of Approved Laboratories**

U.I.M. shall send *Doping Control Samples* for analysis only to WADA-accredited laboratories or as otherwise approved by WADA. The choice of the WADA-accredited laboratory (or other laboratory or method approved by WADA) used for the *Sample* analysis shall be determined exclusively by U.I.M.

*[Comment to Article 6.1: Violations of Article 2.1 (Presence of a Prohibited Substance or its Metabolites or Markers) may be established only by Sample analysis performed by a WADA-approved laboratory or another laboratory specifically authorized by WADA. Violations of other Articles may be established using analytical results from other laboratories so long as the results are reliable.]*

## **6.2 Purpose of Collection and Analysis of Samples**

*Samples* shall be analyzed to detect *Prohibited Substances* and *Prohibited Methods* identified on the *Prohibited List* and other substances as may be directed by WADA pursuant to the Monitoring Program described in Article 4.5 of the *Code* or to assist U.I.M. in profiling relevant parameters in a Driver's urine, blood or other matrix, including DNA or genomic profiling, for anti-doping purposes.

*[Comment to Article 6.2: For example, relevant profile information could be used to direct Target Testing or to support an anti-doping rule violation proceeding under Article 2.2 (Use of a Prohibited Substance), or both.]*

## **6.3 Research on Samples**

No *Sample* may be used for any purpose other than as described in Article 6.2 without the *Driver's* written consent. *Samples* used (with the *Driver's* consent) for purposes other than Article 6.2 shall have any means of identification removed such that they cannot be traced back to a particular *Driver*.

## **6.4 Standards for Sample Analysis and Reporting**

Laboratories shall analyze *Doping Control Samples* and report results in conformity with the *International Standard* for Laboratories.

## **6.5 Retesting Samples**

A *Sample* may be reanalyzed for the purposes described in Article 6.2 at any time exclusively at the direction of U.I.M. or WADA. The circumstances and conditions for retesting *Samples* shall conform with the requirements of the *International Standard* for Laboratories.

*[Comment to Article 6.5: Although this Article is new, Anti-Doping Organizations have always had the authority to reanalyze Samples. The*

*International Standard for Laboratories or a new technical document which is made a part of the International Standard will harmonize the protocol for such retesting.]*

## **ARTICLE 7 RESULTS MANAGEMENT**

### **7.1 Results Management for Tests Initiated by U.I.M.**

Results management for tests initiated by U.I.M. (including tests performed by *WADA* pursuant to agreement with U.I.M.) shall proceed as set forth below:

**7.1.1** The results from all analyses must be sent to U.I.M. in encoded form, in a report signed by an authorised representative of the laboratory. All communication must be conducted in confidentiality and in conformity with *ADAMS*, a database management tool developed by *WADA*. *ADAMS* is consistent with data privacy statutes and norms applicable to *WADA* and other organizations using it.

**7.1.2** Upon receipt of an *A Sample Adverse Analytical Finding*, the U.I.M. Independent Doping Review Panel shall conduct a review to determine whether: (a) the *Adverse Analytical Finding* is consistent with an applicable TUE, or (b) there is any apparent departure from the *International Standard for Testing or International Standard for Laboratories* that caused the *Adverse Analytical Finding*.

**[7.1.2.1** The U.I.M. Executive shall appoint an Independent Doping Review Panel consisting of a Chair and 2 other members with experience in anti-doping. All members of the panel shall be otherwise independent from U.I.M. Each panel member shall serve a term of four years. In each case the Chair of the panel shall appoint 1 or more members of the panel (which may include the Chair) to conduct the review discussed in Articles 7.1.2 and 7.1.8 and to review any other potential violations of these Anti-Doping Rules as may be requested by U.I.M.

**7.1.3** In the following circumstances:

- (a) The *Adverse Analytical Finding* is for a Glucocorticosteroid, formoterol, salbutamol, salmeterol or terbutaline; and
- (b) The *Sample* in question was provided by a Driver who is not in U.I.M.'s *Registered Testing Pool*, during his/her participation in an *International Event* for which (in accordance with Article 7.13 of the *International Standard* for Therapeutic Use Exemptions and Article 4.4.3 of these Anti-Doping Rules U.I.M. does not require a TUE for asthma medication in advance;

then, before the matter is referred to U.I.M. Independent Review Panel under Article 7.1, the *Driver* shall be given an opportunity to apply to the TUE Committee for a Retroactive TUE in accordance with Article 7.13 of the *International Standard* for Therapeutic Use Exemptions. The result of that application shall be forwarded to the U.I.M. Independent Review Panel for consideration in its review of the *Adverse Analytical Finding* under Article 7.1.2.

**7.1.4** If the initial review of an *Adverse Analytical Finding* under Article 7.1.2 does not reveal an applicable TUE, or departure from the *International Standard* for Testing or the *International Standard* for Laboratories that caused the *Adverse Analytical Finding*, U.I.M. shall promptly notify the *Driver* of: (a) the *Adverse Analytical Finding*; (b) the anti-doping rule violated; (c) the *Driver's* right to promptly request the analysis of the B *Sample* or, failing such request, that the B *Sample* analysis may be deemed waived; (d) the scheduled date, time and place for the B *Sample* analysis (which shall be within the time period specified in the *International Standard* for Laboratories) if the *Driver* or U.I.M. chooses to request an analysis of the B *Sample*; (e) the opportunity for the *Driver* and/or the *Driver's* representative to attend the B *Sample* opening and analysis at the scheduled date, time and place if such analysis is requested; and (f) the *Driver's* right to request copies of the A and B *Sample* laboratory documentation package which includes information

as required by the *International Standard* for Laboratories. U.I.M. shall also notify the *Driver's National Anti-Doping Organization* and WADA. If U.I.M. decides not to bring forward the *Adverse Analytical Finding* as an anti-doping rule violation, it shall so notify the *Driver*, the *Driver's National Anti-Doping Organization* and WADA.

**7.1.5** Where requested by the *Driver* or U.I.M., arrangements shall be made for *Testing* the B *Sample* within the time period specified in the *International Standard* for *Testing*. A *Driver* may accept the A *Sample* analytical results by waiving the requirement for B *Sample* analysis. U.I.M. may nonetheless elect to proceed with the B *Sample* analysis.

**7.1.6** The *Driver* and/or his representative shall be allowed to be present at the analysis of the B *Sample* within the time period specified in the *International Standard* for Laboratories. Also a representative of the *Driver's National Association* as well as a representative of U.I.M. shall be allowed to be present.

**7.1.7** If the B *Sample* proves negative, then (unless U.I.M. takes the case forward as an anti-doping rule violation under Article 2.2) the entire test shall be considered negative and the *Driver*, his *National Association*, and U.I.M. shall be so informed.

**7.1.8** If a *Prohibited Substance* or the *Use of a Prohibited Method* is identified, the findings shall be reported to the *Driver*, his *National Association*, U.I.M., and to WADA.

**7.1.9** For apparent anti-doping rule violations that do not involve *Adverse Analytical Findings*, U.I.M. shall conduct any necessary follow-up investigation and, at such time as it is satisfied that an anti-doping rule violation has occurred, it shall then promptly notify the *Driver* of the anti-doping rule which appears to have been violated, and the basis of the violation.

## **7.2 Results Management for Atypical Findings**

**7.2.1** As provided in the *International Standards*, in certain circumstances laboratories are directed to report the presence of

*Prohibited Substances* that may also be produced endogenously as *Atypical Findings* that should be investigated further.

**7.2.2** If a laboratory reports an *Atypical Finding* in respect of a *Sample* collected from a *Driver* by or on behalf of U.I.M., the U.I.M. Independent Doping Review Panel shall conduct a review to determine whether: (a) the *Atypical Finding* is consistent with an applicable TUE that has been granted as provided in the *International Standard* for Therapeutic Use Exemptions, or (b) there is any apparent departure from the *International Standard* for *Testing* or *International Standard* for Laboratories that caused the *Atypical Analytical Finding*.

**7.2.3** If the initial review of an *Atypical Finding* under Article 7.2.2 reveals an applicable TUE or departure from the *International Standard* for *Testing* or the *International Standard* for Laboratories that caused the *Atypical Finding*, the entire test shall be considered negative and the *Driver*, his *National Association*, and U.I.M. shall be so informed.

**7.2.4** If the initial review of an *Atypical Finding* under Article 7.2.2 does not reveal an applicable TUE or departure from the *International Standard* for *Testing* or the *International Standard* for Laboratories that caused the *Atypical Finding*, U.I.M. shall conduct the follow-up investigation required by the *International Standards*. If, once that investigation is completed, it is concluded that the *Atypical Finding* should be considered an *Adverse Analytical Finding*, U.I.M. shall pursue the matter in accordance with Article 7.1.3.

**7.2.5** U.I.M. will not provide notice of an *Atypical Finding* until it has completed its investigation and has decided whether it will bring the *Atypical Finding* forward as an *Adverse Analytical Finding* unless one of the following circumstances exists:

If U.I.M. determines the B *Sample* should be analyzed prior to the conclusion of its follow-up investigation, it may conduct the B *Sample* analysis after notifying the *Driver*, with such notice to include a description of the *Atypical Finding* and the information described in Article 7.1.3(c) to (f).



### **7.3 Results Management for Tests Initiated During Other International Events**

Results management and the conduct of hearings from a test by a Major Event Organization, shall be managed, as far as sanctions beyond Disqualification from the Event or the results of the Event, by U.I.M.

### **7.4 Results Management for Tests initiated by National Associations**

Results management conducted by *National Associations* shall be consistent with the general principles for effective and fair results management which underlie the detailed provisions set forth in Article 7. Results of all *Doping Controls* shall be reported to U.I.M. and to WADA within 14 days of the conclusion of the *National Association's* results management process. Any apparent anti-doping rule violation by a *Driver* who is a member of that *National Association* shall be promptly referred to an appropriate hearing panel established pursuant to the rules of the *National Association* or national law. Apparent anti-doping rule violations by *Drivers* who are members of another *National Association* shall be referred to the *Driver's National Association* for hearing.

### **7.5 Results Management for Whereabouts Violations**

**7.5.1** Results management in respect of an apparent *Filing Failure* by a *Driver* in U.I.M.'s *Registered Testing Pool* shall be conducted by U.I.M. in accordance with Article 11.6.2 of the *International Standard for Testing* (unless it has been agreed in accordance with Article 5.5.4 that the *National Association* or *National Anti-Doping Organization* shall take such responsibility).

**7.5.2** Results management in respect of an apparent *Missed Test* by a *Driver* in U.I.M.'s *Registered Testing Pool* as a result of an attempt to test the *Driver* by or on behalf of U.I.M. shall be conducted by U.I.M. in accordance with Article 11.6.3 of the *International Standard for Testing*. Results management in respect of an apparent *Missed Test* by such *Driver* as a result of an attempt to test the *Driver* by or on behalf of another *Anti-*

*Doping Organization* shall be conducted by that other *Anti-Doping Organization* in accordance with Article 11.7.6(c) of the *International Standard for Testing*.

**7.5.3** Where, in any eighteen-month period, a Driver in U.I.M.'s *Registered Testing Pool* is declared to have three Filing Failures, or three Missed Tests, or any combination of Filing Failures or Missed Tests adding up to three in total, whether under these Anti-Doping Rules or under the rules of any other *Anti-Doping Organization*, U.I.M. shall bring them forward as an apparent anti-doping rule violation.

## **7.6 Provisional Suspensions**

**7.6.1** If analysis of an A *Sample* has resulted in an *Adverse Analytical Finding* for a *Prohibited Substance* that is not a Specified Substance, and a review in accordance with Article 7.1.2 does not reveal an applicable TUE or departure from the *International Standard for Testing* or the *International Standard for Laboratories* that caused the *Adverse Analytical Finding*, U.I.M. shall *Provisionally Suspend* the *Driver* pending the hearing panel's determination of whether he/she has committed an anti-doping rule violation.

**7.6.2** In any case not covered by Article 7.6.1 where U.I.M. decides to take the matter forward as an apparent anti-doping rule violation in accordance with the foregoing provisions of this Article 7, the U.I.M. Executive, after consultation with the U.I.M. Independent Review Panel, may *Provisionally Suspend* the *Driver* pending the hearing panel's determination of whether he/she has committed an anti-doping rule violation.

**7.6.3** Where a *Provisional Suspension* is imposed, whether pursuant to Article 7.6.1 or Article 7.6.2, the *Driver* shall be given either (a) an opportunity for a *Provisional Hearing* before imposition of the *Provisional Suspension* or on a timely basis after imposition of the *Provisional Suspension*; or (b) an opportunity for an expedited hearing in accordance with Article 8 (Right to a Fair Hearing) on a timely basis after imposition of a *Provisional Suspension*. *National Associations* shall impose

*Provisional Suspensions* in accordance with the principles set forth in this Article 7.6.

**7.6.4** If a *Provisional Suspension* is imposed based on an *Adverse Analytical Finding* in respect of an *A Sample*, and any subsequent analysis of the *B Sample* analysis does not confirm the *A Sample* analysis, then the *Driver* shall not be subject to any further *Provisional Suspension* on account of a violation of Article 2.1 of the *Code* (Presence of a *Prohibited Substance* or its *Metabolites* or *Markers*). In circumstances where the *Driver* or the *Driver's* team as may be provided in the rules of the U.I.M. has been removed from a *Competition* based on a violation of Article 2.1 and the subsequent *B Sample* analysis does not confirm the *A Sample* finding, U.I.M., without otherwise affecting the *Competition*, it is still possible for the *Driver* or team to be reinserted, the *Driver* or team may continue to take part in the *Competition*.

*[Comment to Article 7.6: Before a Provisional Suspension can be unilaterally imposed by an Anti-Doping Organization, the internal review specified in the Code must first be completed. In addition, a Signatory imposing a Provisional Suspension is required to give the Driver an opportunity for a Provisional Hearing either before or promptly after the imposition of the Provisional Suspension, or an expedited final hearing under Article 8 promptly after imposition of the Provisional Suspension. The Driver has a right to appeal under Article 13.2.]*

*In the rare circumstance where the B Sample analysis does not confirm the A Sample finding, the Driver who had been provisionally suspended will be allowed, where circumstances permit, to participate in subsequent Competitions during the Event..*

*Drivers shall receive credit for a Provisional Suspension against any period of Ineligibility which is ultimately imposed as provided in Article 10.9.3.]*

## **7.7 Retirement from Sport**

If a *Driver* or other *Person* retires while a results management process is underway, U.I.M. retains jurisdiction to complete its results

management process. If a Driver or other *Person* retires before any results management process has begun and U.I.M. would have had results management jurisdiction over the *Driver* or other *Person* at the time the *Driver* or other *Person* committed an anti-doping rule violation, U.I.M. has jurisdiction to conduct results management.

*[Comment to Article 7.7: Conduct by a Driver or other Person before the Driver or other Person was subject to the jurisdiction of any Anti-Doping Organization would not constitute an anti-doping rule violation but could be a legitimate basis for denying the Driver or other Person membership in a sports organization.]*

## **ARTICLE 8 RIGHT TO A FAIR HEARING**

### **8.1 Hearings arising out of U.I.M. Testing or Tests at International Events**

**8.1.1** The U.I.M. Executive shall appoint a standing panel consisting of a Chair and four other experts with experience in anti-doping (“U.I.M. Doping Hearing Panel”). The Chair shall be a lawyer. Each panel member shall be otherwise independent of U.I.M. Each panel member shall serve a term of four years.

**8.1.2** When it appears, following the Results Management process described in Article 7, that these Anti-Doping Rules have been violated in connection with U.I.M. *Testing* or *Testing* at an *International Event* then the case shall be assigned to the U.I.M. Doping Hearing Panel for adjudication.

**8.1.3** The Chair of the U.I.M. Doping Hearing Panel shall appoint three members from the panel (which may include the Chair) to hear each case. At least one appointed member shall be a lawyer. The appointed members shall have had no prior involvement with the case and shall not have the same nationality as the *Driver* or other *Person* alleged to have violated these Anti-Doping Rules.

**8.1.4** Hearings pursuant to this Article shall be completed expeditiously following the completion of the results management process described in Article 7. Hearings held in

connection with *Events* may be conducted on an expedited basis.

**8.1.5** The *National Association of the Driver* or other *Person* alleged to have violated these Anti-Doping Rules may attend the hearing as an observer.

**8.1.6** U.I.M. shall keep WADA fully apprised as to the status of pending cases and the result of all hearings.

**8.1.7** A *Driver* or other *Person* may forego a hearing by acknowledging the Anti-Doping Rule violation and accepting *Consequences* consistent with Articles 9 and 10 as proposed by U.I.M. The right to a hearing may be waived either expressly or by the *Driver's* or other *Person's* failure to challenge U.I.M.'s assertion that an anti-doping rule violation has occurred within 28 days. Where no hearing occurs, U.I.M. shall submit to the persons described in Article 13.2.3 a reasoned decision explaining the action taken.

**8.1.8** Decisions of the U.I.M. Doping Hearing Panel may be appealed to Court of Arbitration for Sport as provided in Article 13.

## **8.2 Hearings Arising Out of National Testing**

**8.2.1** When it appears, following the Results Management process described in Article 7, that these Anti-Doping Rules have been violated in connection with *Testing* other than in connection with U.I.M. *Testing* or *Testing* at an *International Event*, the *Driver* or other *Person* involved shall be brought before a disciplinary panel of the *Driver* or other *Person's National Association* for a hearing to adjudicate whether a violation of these Anti-Doping Rules occurred and if so what *Consequences* should be imposed.

**8.2.2** Hearings pursuant to this Article 8.2 shall be completed expeditiously and in all cases within three months of the completion of the Results Management process described in Article 7. Hearings held in connection with *Events* may be conducted by an expedited process. If the completion of the

hearing is delayed beyond three months, U.I.M. may elect to bring the case directly before the U.I.M. Doping Hearing Panel at the responsibility and at the expense of the *National Association*.

**8.2.3** *National Associations* shall keep U.I.M. and WADA fully apprised as to the status of pending cases and the results of all hearings.

**8.2.4** U.I.M. and WADA shall have the right to attend hearings as an observer.

**8.2.5** The *Driver* or other *Person* may forego a hearing by acknowledging the violation of these Anti-Doping Rules and accepting *Consequences* consistent with Articles 9 and 10 as proposed by the *National Association*. The right to a hearing may be waived either expressly or by the *Driver's* or other *Person's* failure to challenge the *National Association's* assertion that an anti-doping rule violation has occurred within 28 days. Where no hearing occurs, the *National Association* shall submit to the persons described in Article 13.2.3 a reasoned decision explaining the action taken.

**8.2.6** Decisions by *National Associations*, whether as the result of a hearing or the *Driver* or other *Person's* acceptance of *Consequences*, may be appealed as provided in Article 13.

**8.2.7** Hearing decisions by the *National Association* shall not be subject to further administrative review at the national level except as provided in Article 13 or required by applicable national law.

**8.3 Principles for a Fair Hearing** All hearings pursuant to either Article 8.1 or 8.2 shall respect the following principles:

- a timely hearing;
- fair and impartial hearing panel;
- the right to be represented by counsel at the *Person's* own expense;
- the right to be informed in a fair and timely manner of the asserted anti-doping rule violation;

- the right to respond to the asserted anti-doping rule violation and resulting *Consequences*;
- the right of each party to present evidence, including the right to call and question witnesses (subject to the hearing panel's discretion to accept testimony by telephone or written submission);
- the *Person's* right to an interpreter at the hearing, with the hearing panel to determine the identity, and responsibility for the cost of the interpreter; and
- a timely, written, reasoned decision, specifically including an explanation of the reason(s) for any period of *Ineligibility*.]

## ARTICLE 9 AUTOMATIC DISQUALIFICATION OF INDIVIDUAL RESULTS

A violation of these Anti-Doping Rules in *Individual Sports* in connection with an *In-Competition* test automatically leads to *Disqualification* of the result obtained in that *Competition* with all resulting consequences, including forfeiture of any medals, points and prizes.

*[Comment to Article 9: When a Driver wins a gold medal with a Prohibited Substance in his or her system, that is unfair to the other Drivers in that Competition regardless of whether the gold medalist was at fault in any way. Only a "clean" Driver should be allowed to benefit from his or her competitive results.*

*In sports which are not Team Sports but where awards are given to teams, Disqualification or other disciplinary action against the team when one or more team members have committed an anti-doping rule violation shall be as provided in the applicable rules of U.I.M.]*

## ARTICLE 10 SANCTIONS ON INDIVIDUALS

### 10.1 *Disqualification of Results in Event During which an Anti-Doping Rule Violation Occurs*

An *Anti-Doping Rule* violation occurring during or in connection with an *Event* may lead to *Disqualification* of all of the *Driver's* individual

results obtained in that *Event* with all consequences, including forfeiture of all medals, points and prizes, except as provided in Article 10.1.1.

*[Comment to Article 10.1: Whereas Article 9 (Automatic Disqualification of Individual Results) disqualifies the result in a single Competition in which the Driver tested positive, this Article may lead to Disqualification of all results in all races during the Event. Factors to be included in considering whether to disqualify other results in an Event might include, for example, the severity of the Driver's anti-doping rule violation and whether the Driver tested negative in the other Competitions.]*

**10.1.1** If the *Driver* establishes that he or she bears *No Fault or Negligence* for the violation, the *Driver's* individual results in the other *Competition* shall not be *Disqualified* unless the *Driver's* results in *Competition* other than the *Competition* in which the anti-doping rule violation occurred were likely to have been affected by the *Driver's* anti-doping rule violation.

## **10.2 *Ineligibility for Presence, Use or Attempted Use, or Possession of Prohibited Substances and Prohibited Methods***

The period of *Ineligibility* imposed for a violation of Article 2.1 (Presence of *Prohibited Substance* or its *Metabolites* or *Markers*), Article 2.2 (*Use or Attempted Use of Prohibited Substance or Prohibited Method*) or Article 2.6 (*Possession of Prohibited Substances and Methods*) shall be as follows, unless the conditions for eliminating or reducing the period of *Ineligibility*, as provided in Articles 10.4 and 10.5, or the conditions for increasing the period of *Ineligibility*, as provided in Article 10.6, are met:

First violation: Two (2) years' *Ineligibility*.

*[Comment to Article 10.2: Harmonization of sanctions has been one of the most discussed and debated areas of anti-doping. Harmonization means that the same rules and criteria are applied to assess the unique facts of each case. Arguments against requiring harmonization of sanctions are based on differences between sports including, for example, the following: in some sports the Drivers are professionals making a sizable income from the sport and in others the Drivers are*



*true amateurs; in those sports where a Driver's career is short (e.g., artistic gymnastics) a two year disqualification has a much more significant effect on the Driver than in sports where careers are traditionally much longer (e.g., equestrian and shooting); in Individual Sports, the Driver is better able to maintain competitive skills through solitary practice during disqualification than in other sports where practice as part of a team is more important. A primary argument in favor of harmonization is that it is simply not right that two Drivers from the same country who test positive for the same Prohibited Substance under similar circumstances should receive different sanctions only because they participate in different sports. In addition, flexibility in sanctioning has often been viewed as an unacceptable opportunity for some sporting bodies to be more lenient with dopers. The lack of harmonization of sanctions has also frequently been the source of jurisdictional conflicts between IFs and National Anti-Doping Organizations.]*

### **10.3 Ineligibility for Other Anti-Doping Rule Violations**

The period of *Ineligibility* for violations of these Anti-Doping Rules other than as provided in Article 10.2 shall be as follows:

**10.3.1** For violations of Article 2.3 (refusing or failing to submit to *Sample* collection) or Article 2.5 (*Tampering with Doping Control*), the *Ineligibility* period shall be two (2) years unless the conditions provided in Article 10.5, or the conditions provided in Article 10.6, are met.

**10.3.2** For violations of Article 2.7 (*Trafficking*) or Article 2.8 (Administration of *Prohibited Substance* or *Prohibited Method*), the period of *Ineligibility* imposed shall be a minimum of four (4) years up to lifetime *Ineligibility* unless the conditions provided in Article 10.5 are met. An anti-doping rule violation involving a *Minor* shall be considered a particularly serious violation, and, if committed by *Driver Support Personnel* for violations other than specified Substances shall result in lifetime *Ineligibility* for such *Driver Support Personnel*. In addition, significant violations of such Articles which also violate non-sporting laws and regulations, shall be reported to the competent administrative, professional or judicial authorities.

*[Comment to Article 10.3.2: Those who are involved in doping Drivers or covering up doping should be subject to sanctions which are more severe than the Drivers who test positive. Since the authority of sport organizations is generally limited to Ineligibility for credentials, membership and other sport benefits, reporting Driver Support Personnel to competent authorities is an important step in the deterrence of doping.]*

**10.3.3** For violations of Article 2.4 (Filing Failures and/ or Missed Tests), the period of *Ineligibility* shall be at a minimum one (1) year and at a maximum two (2) years based on the *Driver's* degree of fault.

*[Comment to Article 10.3.3: The sanction under Article 10.3.3 shall be two years where all three filing failures or missed tests are inexcusable. Otherwise, the sanction shall be assessed in the range of two years to one year, based on the circumstances of the case.]*

#### **10.4 Elimination or Reduction of the Period of *Ineligibility* for specified Substances under specific Circumstances**

Where a *Driver* or other *Person* can establish how a specified Substance entered his or her body or came into his or her possession and that such specified Substance was not intended to enhance the *Driver's* sport performance or mask the use of a performance-enhancing substance, the period of *Ineligibility* found in Article 10.2 shall be replaced with the following:

First violation: At a minimum, a reprimand and no period of *Ineligibility* from future *Events*, and at a maximum, two (2) years of *Ineligibility*.

To justify any elimination or reduction, the *Driver* or other *Person* must produce corroborating evidence in addition to his or her word which establishes to the comfortable satisfaction of the hearing panel the absence of an intent to enhance sport performance or mask the use of a performance enhancing substance. The *Driver* or other *Person's* degree of fault shall be the criterion considered in assessing any reduction of the period of *Ineligibility*.

*[Comment to Article 10.4: specified Substances as now defined in Article 4.2.2 are not necessarily less serious agents for purposes of sports doping than other Prohibited Substances (for example, a stimulant that is listed as a specified Substance could be very effective to a Driver in competition); for that reason, a Driver who does not meet the criteria under this Article would receive a two-year period of Ineligibility and could receive up to a four-year period of Ineligibility under Article 10.6. However, there is a greater likelihood that specified Substances, as opposed to other Prohibited Substances, could be susceptible to a credible, non-doping explanation.]*

*This Article applies only in those cases where the hearing panel is comfortably satisfied by the objective circumstances of the case that the Driver in taking a Prohibited Substance did not intend to enhance his or her sport performance. Examples of the type of objective circumstances which in combination might lead a hearing panel to be comfortably satisfied of no performance-enhancing intent would include: the fact that the nature of the specified Substance or the timing of its ingestion would not have been beneficial to the Driver; the Driver's open Use or disclosure of his or her Use of the specified Substance; and a contemporaneous medical records file substantiating the non-sport-related prescription for the specified Substance. Generally, the greater the potential performance-enhancing benefit, the higher the burden on the Driver to prove lack of an intent to enhance sport performance.*

*While the absence of intent to enhance sport performance must be established to the comfortable satisfaction of the hearing panel, the Driver may establish how the specified Substance entered the body by a balance of probability.*

*In assessing the Driver's or other Person's degree of fault, the circumstances considered must be specific and relevant to explain the Driver's or other Person's departure from the expected standard of behavior. Thus, for example, the fact that a Driver would lose the opportunity to earn large sums of money during a period of Ineligibility or the fact that the Driver only has a short time left in his or her career or the timing of the sporting calendar would not be relevant factors to be considered in reducing the period of Ineligibility under this Article. It is*

*anticipated that the period of Ineligibility will be eliminated entirely in only the most exceptional cases.]*

## **10.5 Elimination or Reduction of Period of *Ineligibility* Based on Exceptional Circumstances**

### **10.5.1 *No Fault or Negligence***

If a Driver establishes in an individual case that he or she bears *No Fault or Negligence*, the otherwise applicable period of *Ineligibility* shall be eliminated. When a *Prohibited Substance* or its *Markers* or *Metabolites* is detected in a Driver's *Sample* in violation of Article 2.1 (presence of *Prohibited Substance*), the *Driver* must also establish how the *Prohibited Substance* entered his or her system in order to have the period of *Ineligibility* eliminated. In the event this Article is applied and the period of *Ineligibility* otherwise applicable is eliminated, the anti-doping rule violation shall not be considered a violation for the limited purpose of determining the period of *Ineligibility* for multiple violations under Article 10.7.

### **10.5.2 *No Significant Fault or Negligence***

If a Driver or other *Person* establishes in an individual case that he or she bears *No significant Fault or Negligence*, then the period of *Ineligibility* may be reduced, but the reduced period of *Ineligibility* may not be less than one-half of the period of *Ineligibility* otherwise applicable. If the otherwise applicable period of *Ineligibility* is a lifetime, the reduced period under this section may be no less than 8 years. When a *Prohibited Substance* or its *Markers* or *Metabolites* is detected in a Driver's *Sample* in violation of Article 2.1 (Presence of *Prohibited Substance* or its *Metabolites* or *Markers*), the *Driver* must also establish how the *Prohibited Substance* entered his or her system in order to have the period of *Ineligibility* reduced.

*[Comment to Articles 10.5.1 and 10.5.2: U.I.M.'s Anti-Doping Rules provide for the possible reduction or elimination of the period of Ineligibility in the unique circumstance where the Driver can establish that he or she had No Fault or Negligence, or No significant Fault or*

*Negligence, in connection with the violation. This approach is consistent with basic principles of human rights and provides a balance between those Anti-Doping Organizations that argue for a much narrower exception, or none at all, and those that would reduce a two year suspension based on a range of other factors even when the Driver was admittedly at fault. These Articles apply only to the imposition of sanctions; they are not applicable to the determination of whether an anti-doping rule violation has occurred. Article 10.5.2 may be applied to any anti-doping violation even though it will be especially difficult to meet the criteria for a reduction for those anti-doping rule violations where knowledge is an element of the violation.*

*Articles 10.5.1 and 10.5.2 are meant to have an impact only in cases where the circumstances are truly exceptional and not in the vast majority of cases.*

*To illustrate the operation of Article 10.5.1, an example where No Fault or Negligence would result in the total elimination of a sanction is where a Driver could prove that, despite all due care, he or she was sabotaged by a competitor. Conversely, a sanction could not be completely eliminated on the basis of No Fault or Negligence in the following circumstances: (a) a positive test resulting from a mislabeled or contaminated vitamin or nutritional supplement (Drivers are responsible for what they ingest (Article 2.1.1) and have been warned against the possibility of supplement contamination); (b) the administration of a Prohibited Substance by the Driver's personal physician or trainer without disclosure to the Driver (Drivers are responsible for their choice of medical personnel and for advising medical personnel that they cannot be given any Prohibited Substance); and (c) sabotage of the Driver's food or drink by a spouse, coach or other person within the Driver's circle of associates (Drivers are responsible for what they ingest and for the conduct of those persons to whom they entrust access to their food and drink). However, depending on the unique facts of a particular case, any of the referenced illustrations could result in a reduced sanction based on No significant Fault or Negligence. (For example, reduction may well be appropriate in illustration (a) If the Driver clearly establishes that the cause of the positive test was contamination in a common multiple vitamin purchased from a source with no*

connection to Prohibited Substances and the Driver exercised care in not taking other nutritional supplements.)

For purposes of assessing the Driver or other Person's fault under Articles 10.5.1 and 10.5.2, the evidence considered must be specific and relevant to explain the Driver or other Person's departure from the expected standard of behavior. Thus, for example the fact that a Driver would lose the opportunity to earn large sums of money during a period of Ineligibility or the fact that the Driver only has a short time left in his or her career or the timing of the sporting calendar would not be relevant factors to be considered in reducing the period of Ineligibility under this Article.

While minors are not given special treatment per se in determining the applicable sanction, certainly youth and lack of experience are relevant factors to be assessed in determining the Driver or other Person's fault under Article 10.5.2, as well as Articles 10.4 and 10.5.1.

Article 10.5.2 should not be applied in cases where Articles 10.3.3 or 10.4 apply, as those Articles already take into consideration the Driver or other Person's degree of fault for purposes of establishing the applicable period of Ineligibility.]

### **10.5.3 Substantial Assistance in Discovering or Establishing Anti-Doping Rule Violations**

The U.I.M. Doping Hearing Panel may, prior to a final appellate decision under Article 13 or the expiration of the time to appeal, suspend a part of the period of *Ineligibility* imposed in an individual case where the *Driver* or other *Person* has provided *Substantial Assistance* to an *Anti-Doping Organization*, criminal authority or professional disciplinary body which results in the *Anti-Doping Organization* discovering or establishing an anti-doping rule violation by another *Person* or which results in a criminal or disciplinary body discovering or establishing a criminal offense or the breach of professional rules by another *Person*. After a final appellate decision under Article 13 or the expiration of time to appeal, U.I.M. may only suspend a part of the applicable period of *Ineligibility* with the approval of WADA. The extent to which the otherwise applicable period of *Ineligibility* may

be suspended shall be based on the seriousness of the anti-doping rule violation committed by the *Driver* or other *Person* and the significance of the *Substantial Assistance* provided by the *Driver* or other *Person* to the effort to eliminate doping in sport. No more than three-quarters of the otherwise applicable period of *Ineligibility* may be suspended. If the otherwise applicable period of *Ineligibility* is a lifetime, the non-suspended period under this Article must be no less than 8 years. If U.I.M. suspends any part of the period of *Ineligibility* under this Article, it shall promptly provide a written justification for its decision to each *Anti-Doping Organization* having a right to appeal the decision. If U.I.M. subsequently reinstates any part of the suspended period of *Ineligibility* because the *Driver* or other *Person* has failed to provide the *Substantial Assistance* which was anticipated, the *Driver* or other *Person* may appeal the reinstatement pursuant to Article 13.2.

*[Comment to Article 10.5.3: The cooperation of Driver, Driver Support Personnel and other Persons who acknowledge their mistakes and are willing to bring other anti-doping rule violations to light is important to clean sport.*

*Factors to be considered in assessing the importance of the Substantial Assistance would include, for example, the number of individuals implicated, the status of those individuals in the sport, whether a scheme involving Trafficking under Article 2.7 or administration under Article 2.8 is involved and whether the violation involved a substance or method which is not readily detectable in Testing. The maximum suspension of the Ineligibility period shall only be applied in very exceptional cases. An additional factor to be considered in connection with the seriousness of the anti-doping rule violation is any performance-enhancing benefit which the Person providing Substantial Assistance may be likely to still enjoy. As a general matter, the earlier in the results management process the Substantial Assistance is provided, the greater the percentage of the period of Ineligibility may be suspended.*

*If the Driver or other Person who is asserted to have committed an anti-doping rule violation claims entitlement to a suspended period of Ineligibility under this Article in connection with the Driver or other*

*Person's waiver of a hearing under Article 8.3 (Waiver of Hearing), U.I.M. shall determine whether a suspension of a portion of the period of Ineligibility is appropriate under this Article. If the Driver or other Person claims entitlement to a suspended period of Ineligibility before the conclusion of a hearing under Article 8 on the anti-doping rule violation, the hearing panel shall determine whether a suspension of a portion of the period of Ineligibility is appropriate under this Article at the same time the hearing panel decides whether the Driver or other Person has committed an anti-doping rule violation. If a portion of the period of Ineligibility is suspended, the decision shall explain the basis for concluding the information provided was credible and was important to discovering or proving the anti-doping rule violation or other offense. If the Driver or other Person claims entitlement to a suspended period of Ineligibility after a final decision finding an anti-doping rule violation has been rendered and is not subject to appeal under Article 13, but the Driver or other Person is still serving the period of Ineligibility, the Driver or other Person may apply to U.I.M. to consider a suspension in the period of Ineligibility under this Article. Any such suspension of the period of Ineligibility shall require the approval of WADA. If any condition upon which the suspension of a period of Ineligibility is based is not fulfilled, U.I.M. shall reinstate the period of Ineligibility which would otherwise be applicable. Decisions rendered by U.I.M. under this Article may be appealed pursuant Article 13.2.*

*This is the only circumstance under U.I.M.'s Anti-Doping Rules where the suspension of an otherwise applicable period of Ineligibility is authorized.]*

#### **10.5.4 Admission of an Anti-Doping Rule Violation in the Absence of Other Evidence**

Where a Driver or other *Person* voluntarily admits the commission of an anti-doping rule violation before having received notice of a *Sample* collection which could establish an anti-doping rule violation (or, in the case of an anti-doping rule violation other than Article 2.1, before receiving first notice of the admitted violation pursuant to Article 7) and that admission is the only reliable evidence of the violation at the time of admission,



then the period of *Ineligibility* may be reduced, but not below one-half of the period of *Ineligibility* otherwise applicable.

*[Comment to Article 10.5.4: This Article is intended to apply when a Driver or other Person comes forward and admits to an anti-doping rule violation in circumstances where no Anti-Doping Organization is aware that an anti-doping rule violation might have been committed. It is not intended to apply to circumstances where the admission occurs after the Driver or other Person knows he or she is about to be caught.]*

**10.5.5** Where a Driver or Other Person Establishes Entitlement to Reduction in Sanction under More than One Provision of this Article

Before applying any reductions under Articles 10.5.2, 10.5.3 or 10.5.4, the otherwise applicable period of *Ineligibility* shall be determined in accordance with Articles 10.2, 10.3, 10.4 and 10.6. If the *Driver* or other *Person* establishes entitlement to a reduction or suspension of the period of *Ineligibility* under two or more of Articles 10.5.2, 10.5.3 or 10.5.4, then the period of *Ineligibility* may be reduced or suspended, but not below one-quarter of the otherwise applicable period of *Ineligibility*.

*[Comment to Article 10.5.5: The appropriate sanction is determined in a sequence of four steps. First, the hearing panel determines which of the basic sanctions (Article 10.2, Article 10.3, Article 10.4 or Article 10.6) applies to the particular anti-doping rule violation. In a second step, the hearing panel establishes whether there is a basis for elimination or reduction of the sanction (Articles 10.5.1 through 10.5.4). Note, however, not all grounds for elimination or reduction may be combined with the provisions on basic sanctions. For example, Article 10.5.2 does not apply in cases involving Articles 10.3.3 or 10.4, since the hearing panel, under Articles 10.3.3 and 10.4, will already have determined the period of Ineligibility based on the Driver or other Person's degree of fault. In a third step, the hearing panel determines under Article 10.5.5 whether the Driver or other Person is entitled to a reduction under more than one provision of Article 10.5. Finally, the hearing panel decides on the commencement of the period of Ineligibility under Article 10.9. The following four examples demonstrate the proper sequence of analysis:*

### Example 1.

*Facts:* An Adverse Analytical Finding involves the presence of an anabolic steroid; the Driver promptly admits the anti-doping rule violation as alleged; the Driver establishes No significant Fault (Article 10.5.2); and the Driver provides important Substantial Assistance (Article 10.5.3).

#### Application of Article 10:

1. The basic sanction would be two years under Article 10.2. (Aggravating circumstances (Article 10.6) would not be considered because the Driver promptly admitted the violation. Article 10.4 would not apply because a steroid is not a specified Substance.)
2. Based on No significant Fault alone, the sanction could be reduced up to one-half of the two years. Based on Substantial Assistance alone, the sanction could be reduced up to three-quarters of the two years.
3. Under Article 10.5.5, in considering the possible reduction for No significant Fault and Substantial Assistance together, the most the sanction could be reduced is up to three-quarters of the two years. Thus, the minimum sanction would be a six-month period of Ineligibility.
4. Under Article 10.9.2, because the Driver promptly admitted the anti-doping rule violation, the period of Ineligibility could start as early as the date of Sample collection, but in any event the Driver would have to serve at least one-half of the Ineligibility period (minimum three months) after the date of the hearing decision.

### Example 2.

*Facts:* An Adverse Analytical Finding involves the presence of an anabolic steroid; aggravating circumstances exist and the Driver is unable to establish that he did not knowingly commit the anti-doping rule violation; the Driver does not promptly admit the anti-doping rule violation as alleged; but the Driver does provide important Substantial Assistance (Article 10.5.3).

#### Application of Article 10:

1. The basic sanction would be between two and four years Ineligibility as provided in Article 10.6.

2. *Based on Substantial Assistance, the sanction could be reduced up to three-quarters of the maximum four years.*
3. *Article 10.5.5 does not apply.*
4. *Under Article 10.9.2, the period of Ineligibility would start on the date of the hearing decision.*

### Example 3.

*Facts: An Adverse Analytical Finding involves the presence of a specified Substance; the Driver establishes how the specified Substance entered his body and that he had no intent to enhance his sport performance; the Driver establishes that he had very little fault; and the Driver provides important Substantial Assistance (Article 10.5.3).*

### Application of Article 10:

1. *Because the Adverse Analytical Finding involved a specified Substance and the Driver has satisfied the other conditions of Article 10.4, the basic sanction would fall in the range between a reprimand and two years Ineligibility. The hearing panel would assess the Driver's fault in imposing a sanction within that range. (Assume for illustration in this example that the panel would otherwise impose a period of Ineligibility of eight months.)*
2. *Based on Substantial Assistance, the sanction could be reduced up to three-quarters of the eight months. (No less than two months.) [No significant Fault (Article 10.2) would not be applicable because the Driver's degree of fault was already taken into consideration in establishing the eight-month period of Ineligibility in step 1.]*
3. *Article 10.5.5 does not apply.*
4. *Under Article 9.2, because the Driver promptly admitted the anti-doping rule violation, the period of Ineligibility could start as early as the date of Sample collection, but in any event, the Driver would have to serve at least half of the Ineligibility period after the date of the hearing decision. (Minimum one month.)*

#### Example 4.

*Facts:* A Driver who has never had an Adverse Analytical Finding or been confronted with an anti-doping rule violation spontaneously admits that he intentionally used multiple Prohibited Substances to enhance his performance. The Driver also provides important Substantial Assistance (Article 10.5.3).

#### Application of Article 10:

1. While the intentional Use of multiple Prohibited Substances to enhance performance would normally warrant consideration of aggravating circumstances (Article 10.6), the Driver's spontaneous admission means that Article 10.6 would not apply. The fact that the Driver's Use of Prohibited Substances was intended to enhance performance would also eliminate the application of Article 10.4 regardless of whether the Prohibited Substances Used were specified Substances. Thus, Article 10.2 would be applicable and the basic period of Ineligibility imposed would be two years.

2. Based on the Driver's spontaneous admissions (Article 10.5.4) alone, the period of Ineligibility could be reduced up to one-half of the two years. Based on the Driver's Substantial Assistance (Article 10.5.3) alone, the period of Ineligibility could be reduced up to three-quarters of the two years.

3. Under Article 10.5.5, in considering the spontaneous admission and Substantial Assistance together, the most the sanction could be reduced would be up to three-quarters of the two years. (The minimum period of Ineligibility would be six months.)

4. U.I.M. Article 10.5.4 was considered by the hearing panel in arriving at the minimum six month period of Ineligibility at step 3, the period of Ineligibility would start on the date the hearing panel imposed the sanction. If, however, the hearing panel did not consider the application of Article 10.5.4 in reducing the period of Ineligibility in step 3, then under Article 10.9.2, the commencement of the period of Ineligibility could be started as early as the date the anti-doping rule violation was committed, provided that at least half of that period (minimum of three months) would have to be served after the date of the hearing decision.]

## **10.6 Aggravating Circumstances Which May Increase the Period of Ineligibility**

If U.I.M. establishes in an individual case involving an anti-doping rule violation other than violations under Article 2.7 (Trafficking) and 2.8 (Administration) that aggravating circumstances are present which justify the imposition of a period of *Ineligibility* greater than the standard sanction, then the period of *Ineligibility* otherwise applicable shall be increased up to a maximum of four years unless the *Driver* or other *Person* can prove to the comfortable satisfaction of the hearing panel that he did not knowingly violate the anti-doping rule.

A *Driver* or other *Person* can avoid the application of this Article by admitting the anti-doping rule violation as asserted promptly after being confronted with the anti-doping rule violation by U.I.M.

*[Comment to Article 10.6: Examples of aggravating circumstances which may justify the imposition of a period of Ineligibility greater than the standard sanction are: the Driver or other Person committed the anti-doping rule violation as part of a doping plan or scheme, either individually or involving a conspiracy or common enterprise to commit anti-doping rule violations; the Driver or other Person used or possessed multiple Prohibited Substances or Prohibited Methods or used or possessed a Prohibited Substance or Prohibited Method on multiple occasions; a normal individual would be likely to enjoy the performance-enhancing effects of the anti-doping rule violation(s) beyond the otherwise applicable period of Ineligibility; the Driver or Person engaged in deceptive or obstructing conduct to avoid the detection or adjudication of an anti-doping rule violation.*

*For the avoidance of doubt, the examples of aggravating circumstances described in this Comment to Article 10.6 are not exclusive and other aggravating factors may also justify the imposition of a longer period of Ineligibility. Violations under Article 2.7 (Trafficking or Attempted Trafficking) and 2.8 (Administration or Attempted Administration) are not included in the application of Article 10.6 because the sanctions for these violations (from four years to lifetime Ineligibility) already build in sufficient discretion to allow consideration of any aggravating circumstance.]*

## 10.7 Multiple Violations

### 10.7.1 Second Anti-Doping Rule Violation

For a Driver's or other *Person's* first anti-doping rule violation, the period of *Ineligibility* is set forth in Articles 10.2 and 10.3 (subject to elimination, reduction or suspension under Articles 10.4 or 10.5, or to an increase under Article 10.6). For a second anti-doping rule violation the period of *Ineligibility* shall be within the range set forth in the table below.

Second Violation First Violation	RS	FFMT	NSF	St	AS	TRA
<b>RS</b>	1-4	2-4	2-4	4-6	8-10	10-life
<b>FFMT</b>	1-4	4-8	4-8	6-8	10-life	life
<b>NSF</b>	1-4	4-8	4-8	6-8	10-life	life
<b>St</b>	2-4	6-8	6-8	8-life	life	life
<b>AS</b>	4-5	10-life	10-life	life	life	life
<b>TRA</b>	8-life	life	Life	life	life	life

Definitions for purposes of the second anti-doping rule violation table:

**RS** (Reduced sanction for specified Substance under Article 10.4): The anti-doping rule violation was or should be sanctioned by a reduced sanction under Article 10.4 because it involved a specified Substance and the other conditions under Article 10.4 were met.

**FFMT** (Filing Failures and/or Missed Tests): The anti-doping rule violation was or should be sanctioned under Article 10.3.3 (Filing Failures and/or Missed Tests).

**NSF** (Reduced sanction for *No significant Fault* or *Negligence*): The anti-doping rule violation was or should be sanctioned by a reduced sanction under Article 10.5.2 because *No significant Fault* or *Negligence* under Article 10.5.2 was proved by the *Driver*.

**St** (Standard sanction under Articles 10.2 or 10.3.1): The anti-doping rule violation was or should be sanctioned by the standard sanction of two years under Article 10.2 or 10.3.1.

**AS** (Aggravated sanction): The anti-doping rule violation was or should be sanctioned by an aggravated sanction under Article 10.6 because the *Anti-Doping Organization* established the conditions set forth under Article 10.6.

**TRA** (*Trafficking* or *Attempted Trafficking* and administration or *Attempted* administration): The anti-doping rule violation was or should be sanctioned by a sanction under Article 10.3.2.

*[Comment to Article 10.7.1: The table is applied by locating the Driver or other Person's first anti-doping rule violation in the left-hand column and then moving across the table to the right to the column representing the second violation. By way of example, assume a Driver receives the standard period of Ineligibility for a first violation under Article 10.2 and then commits a second violation for which he receives a reduced sanction for a specified Substance under Article 10.4. The table is used to determine the period of Ineligibility for the second violation. The table is applied to this example by starting in the left-hand column and going down to the fourth row which is "St" for standard sanction, then moving across the table to the first column which is "RS" for reduced sanction for a specified Substance, thus resulting in a 2-4 year range for the period of Ineligibility for the second violation. The Driver or other Person's degree of fault shall be the criterion considered in assessing a period of Ineligibility within the applicable range.]*

*[Comment to Article 10.7.1 RS Definition: See Article 25.4 with respect to application of Article 10.7.1 to pre-Code anti-doping rule violations.]*

### **10.7.2** Application of Articles 10.5.3 and 10.5.4 to Second Anti-Doping Rule Violation

Where a Driver or other *Person* who commits a second anti-doping rule violation establishes entitlement to suspension or reduction of a portion of the period of *Ineligibility* under Article 10.5.3 or Article 10.5.4, the hearing panel shall first determine the otherwise applicable period of *Ineligibility* within the range established in the table in Article 10.7.1, and then apply the appropriate suspension or reduction of the period of *Ineligibility*. The remaining period of *Ineligibility*, after applying any suspension or reduction under Articles 10.5.3 and 10.5.4, must

be at least one-fourth of the otherwise applicable period of *Ineligibility*.

### 10.7.3 Third Anti-Doping Rule Violation

A third anti-doping rule violation will always result in a lifetime period of *Ineligibility*, except if the third violation fulfills the condition for elimination or reduction of the period of *Ineligibility* under Article 10.4 or involves a violation of Article 2.4 (Filing Failures and/or and Missed Tests). In these particular cases, the period of *Ineligibility* shall be from eight (8) years to lifetime ban.

### 10.7.4 Additional Rules for Certain Potential Multiple Violations

- For purposes of imposing sanctions under Article 10.7, an anti-doping rule violation will only be considered a second violation if the U.I.M. (or its *National Association*) can establish that the *Driver* or other *Person* committed the second anti-doping rule violation after the *Driver* or other *Person* received notice pursuant to Article 7 (Results Management), or after U.I.M. (or its *National Association*) made reasonable efforts to give notice, of the first anti-doping rule violation; If the U.I.M. (or its *National Association*) cannot establish this, the violations shall be considered together as one single first violation, and the sanction imposed shall be based on the violation that carries the more severe sanction; however, the occurrence of multiple violations may be considered as a factor in determining Aggravating Circumstances (Article 10.6).
- If, after the resolution of a first anti-doping rule violation, U.I.M. discovers facts involving an anti-doping rule violation by the *Driver* or other *Person* which occurred prior to notification regarding the first violation, then U.I.M. shall impose an additional sanction based on the sanction that could have been imposed if the two violations would have been adjudicated at the same time. Results in all *Competitions* dating back to the earlier anti-doping rule violation will be *disqualified* as provided in Article 10.8. To avoid the possibility of a finding of Aggravating Circumstances (Article 10.6) on account of the earlier-in-time but later-discovered violation, the *Driver* or other *Person* must



voluntarily admit the earlier anti-doping rule violation on a timely basis after notice of the violation for which he or she is first charged. The same rule shall also apply when U.I.M. discovers facts involving another prior violation after the resolution of a second anti-doping rule violation.

*[Comment to Article 10.7.4: In a hypothetical situation, a Driver commits an anti-doping rule violation on January 1, 2008 which U.I.M. does not discover until December 1, 2008. In the meantime, the Driver commits another anti-doping rule violation on March 1, 2008 and the Driver is notified of this violation by U.I.M. on March 30, 2008 and a hearing panel rules on June 30, 2008 that the Driver committed the March 1, 2008 anti-doping rule violation. The later-discovered violation which occurred on January 1, 2008 will provide the basis for Aggravating Circumstances because the Driver did not voluntarily admit the violation in a timely basis after the Driver received notification of the later violation on March 30, 2008.]*

#### **10.7.5 Multiple Anti-Doping Rule Violations during an Eight-Year Period**

For purposes of Article 10.7, each anti-doping rule violation must take place within the same eight (8) year period in order to be considered multiple violations.

#### **10.8 Disqualification of Results in Competitions Subsequent to Sample Collection or Commission of an Anti-Doping Rule Violation**

In addition to the automatic *disqualification* of the results in the *Competition* which produced the positive *Sample* under Article 9 (Automatic *disqualification* of Individual Results), all other competitive results obtained from the date a positive *Sample* was collected (whether *In-Competition* or *Out-of-Competition*), or other anti-doping rule violation occurred, through the commencement of any *Provisional Suspension* or *Ineligibility* period, shall, unless fairness requires otherwise, be *disqualified* with all of the resulting consequences including forfeiture of any medals, points and prizes.

**10.8.1** As a condition of regaining eligibility after being found to have committed an anti-doping rule violation, the *Driver* must first repay all prize money forfeited under this Article.

**10.8.2** Allocation of Forfeited Prize Money.

Forfeited prize money shall be allocated first to reimburse the collection expenses incurred by the *Anti-Doping Organization* in order to perform the necessary steps to collect the prize money back, then to reimburse the expenses incurred by the *Anti-Doping Organization* in order to conduct results management in the case, with the balance, if any, allocated in accordance with U.I.M.'s specific rules.

*[Comment to Article 10.8.2: Nothing in U.I.M.'s Anti-Doping Rules precludes clea Drivers or other Persons who have been damaged by the actions of a Person who has committed an anti-doping rule violation from pursuing any right which they would otherwise have to seek damages from such Person.]*

## **10.9 Commencement of *Ineligibility* Period**

Except as provided below, the period of *Ineligibility* shall start on the date of the hearing decision providing for *Ineligibility* or, if the hearing is waived, on the date *Ineligibility* is accepted or otherwise imposed.

**10.9.1** Delays Not Attributable to the *Driver* or other *Person*

Where there have been substantial delays in the hearing process or other aspects of *Doping Control* not attributable to the *Driver* or other *Person*, the U.I.M. or *Anti-Doping Organization* imposing the sanction may start the period of *Ineligibility* at an earlier date commencing as early as the date of *Sample* collection or the date on which another anti-doping rule violation last occurred.

**10.9.2** Timely Admission

Where the *Driver* promptly (which, in all events, means before the *Driver* competes again) admits the anti-doping rule violation after being confronted with the anti-doping rule violation by U.I.M., the period of *Ineligibility* may start as early as the date of *Sample* collection or the date on which another anti-doping rule

violation last occurred. In each case, however, where this Article is applied, the *Driver* or other *Person* shall serve at least one-half of the period of *Ineligibility* going forward from the date the *Driver* or other *Person* accepted the imposition of a sanction, the date of a hearing decision imposing a sanction, or the date the sanction is otherwise imposed.

*[Comment to Article 10.9.2: This Article shall not apply where the period of Ineligibility already has been reduced under Article 10.5.4 (Admission of an Anti-Doping Rule Violation in the Absence of Other Evidence).]*

**10.9.3** If a *Provisional Suspension* is imposed and respected by the *Driver*, then the *Driver* shall receive a credit for such period of *Provisional Suspension* against any period of *Ineligibility* which may ultimately be imposed.

**10.9.4** If a *Driver* voluntarily accepts a *Provisional Suspension* in writing from U.I.M. and thereafter refrains from competing, the *Driver* shall receive a credit for such period of voluntary *Provisional Suspension* against any period of *Ineligibility* which may ultimately be imposed. A copy of the *Driver's* voluntary acceptance of a *Provisional Suspension* shall be provided promptly to each party entitled to receive notice of a potential anti-doping rule violation under Article 14.1.

*[Comment to Article 10.9.4: A Driver's voluntary acceptance of a Provisional Suspension is not an admission by the Driver and shall not be used in any way as to draw an adverse inference against the Driver.]*

**10.9.5** No credit against a period of *Ineligibility* shall be given for any time period before the effective date of the *Provisional Suspension* or voluntary *Provisional Suspension* regardless of whether the *Driver* elected not to compete or was suspended by his or her team.

*[Comment to Article 10.9: The text of Article 10.9 has been revised to make clear that delays not attributable to the Driver, timely admission by the Driver and Provisional Suspension are the only justifications for starting the period of Ineligibility earlier than the date of the hearing]*

*decision. This amendment corrects inconsistent interpretation and application of the previous text.]*

## **10.10 Status During *Ineligibility***

### **10.10.1 Prohibition against Participation during *Ineligibility***

No *Driver* or other *Person* who has been declared *Ineligible* may, during the period of *Ineligibility*, participate in any capacity in an *Event* or activity (other than authorized anti-doping education or rehabilitation programs) authorized or organized by U.I.M. or any *National Association* or a club or other member organization of U.I.M. or any *National Association*, or in *Competitions* authorized or organized by any professional league or any international or national level *Event* organization.

A *Driver* or other *Person* subject to a period of *Ineligibility* longer than four years may, after completing four years of the period of *Ineligibility*, participate in local sport events in a sport other than sports subject to the jurisdictions of U.I.M. and its *National Associations*, but only so long as the local sport event is not at a level that could otherwise qualify such *Person* directly or indirectly to compete in (or accumulate points toward) a national championship or *International Event*.

A *Driver* or other *Person* subject to a period of *Ineligibility* shall remain subject to *Testing*.

*[Comment to Article 10.10.1: For example, an ineligible Driver cannot participate in a training camp, exhibition or practice organized by his or her National Association or a club which is a member of that National Association. Further, an ineligible Driver may not compete in a non-Signatory professional league (e.g., the National Hockey League, the National Basketball Association, etc.), Events organized by a non-Signatory International Event organization or a non-Signatory national-level event organization without triggering the consequences set forth in Article 10.10.2. Sanctions in one sport will also be recognized by other sports (see Article 15).]*

### **10.10.2 Violation of the Prohibition of Participation during *Ineligibility***

Where a Driver or other *Person* who has been declared *Ineligible* violates the prohibition against participation during *Ineligibility* described in Article 10.10.1, the results of such participation shall be *disqualified* and the period of *Ineligibility* which was originally imposed shall start over again as of the date of the violation. The new period of *Ineligibility* may be reduced under Article 10.5.2 if the *Driver* or other *Person* establishes he or she bears *No significant Fault or Negligence* for violating the prohibition against participation. The determination of whether a Driver or other *Person* has violated the prohibition against participation, and whether a reduction under Article 10.5.2 is appropriate, shall be made by U.I.M.

*[Comment to Article 10.10.2: If a Driver or other Person is alleged to have violated the prohibition against participation during a period of Ineligibility, U.I.M. shall determine whether the Driver violated the prohibition and, if so, whether the Driver or other Person has established grounds for a reduction in the restarted period of Ineligibility under Article 10.5.2. Decisions rendered by U.I.M. under this Article may be appealed pursuant to Article 13.2.]*

*Where a Driver Support Personnel or other Person substantially assists a Driver in violating the prohibition against participation during Ineligibility, U.I.M. may appropriately impose sanctions under its own disciplinary rules for such assistance.]*

### **10.10.3 Withholding of Financial Support during *Ineligibility***

In addition, for any anti-doping rule violation not involving a reduced sanction for *specified Substances* as described in Article 10.4, some or all sport-related financial support or other sport-related benefits received by such *Person* will be withheld by U.I.M. and its *National Associations*.

### **10.11 Reinstatement *Testing***

As a condition to regaining eligibility at the end of a specified period of *Ineligibility*, a Driver must, during any period of *Provisional Suspension* or *Ineligibility*, make him or herself available for *Out-of-Competition Testing* by U.I.M., the applicable *National Association*,

and any other *Anti-Doping Organization* having *Testing* jurisdiction, and must comply with the whereabouts requirements of Article 11 of the *International Standard for Testing*. If a *Driver* subject to a period of *Ineligibility* retires from sport and is removed from *Out-of-Competition Testing* pools and later seeks reinstatement, the *Driver* shall not be eligible for reinstatement until the *Driver* has notified U.I.M. and the applicable *National Association* and has been subject to *Out-of-Competition Testing* for a period of time equal to the [longer of (a) the period set forth in Article 5.6 and (b)] period of *Ineligibility* remaining as of the date the *Driver* had retired. During such remaining period of *Ineligibility*, a minimum of 2 tests must be conducted on the *Driver* with at least three months between each test. The *National Association* shall be responsible for conducting the necessary tests, but tests by any *Anti-Doping Organization* may be used to satisfy the requirement. The results of such tests shall be reported to U.I.M. In addition, immediately prior to the end of the period of *Ineligibility*, a *Driver* must undergo *Testing* by U.I.M. for the *Prohibited Substances* and *Methods* that are prohibited in *Out-of-Competition Testing*. Once the period of a *Driver's Ineligibility* has expired, and the *Driver* has fulfilled the conditions of reinstatement, then the *Driver* will become automatically re-eligible and no application by the *Driver* or by the *Driver's National Association* will then be necessary.

#### **[10. 12 Imposition of Financial Sanctions**

*Anti-Doping Organizations* may, in their own rules, provide for financial sanctions on account of anti-doping rule violations. However, no financial sanction may be considered a basis for reducing the period of *Ineligibility* or other sanction which would otherwise be applicable under the *Code*.]

## **ARTICLE 11 *Intentionally left blank***

## ARTICLE 12 SANCTIONS AND COSTS ASSESSED AGAINST NATIONAL ASSOCIATIONS

**12.1** The U.I.M. has the authority to withhold some or all funding or other non financial support to *National Associations* that are not in compliance with these Anti-Doping Rules.

**[12.2** *National Associations* shall be obligated to reimburse U.I.M. for all costs (including but not limited to laboratory fees, hearing expenses and travel) related to a violation of these Anti-Doping Rules committed by a Driver or other *Person* affiliated with that *National Association*.]

**12.3** U.I.M. may elect to take additional disciplinary action against National Associations with respect to recognition, the eligibility of its officials and Drivers to participate in International Events and fines based on the following:

**12.3.1** Four or more violations of these Anti-Doping Rules (other than violations involving Articles 2.4 and 10.3) are committed by *Drivers* or other *Persons* affiliated with a *National Association* within a 12-month period in testing conducted by U.I.M. or Anti-Doping Organizations other than the *National Association* or its *National Anti-Doping Organization*. [In such event the U.I.M. may in its discretion elect to: (a) ban all officials from that *National Association* for participation in any U.I.M. activities for a period of up to two years and/or (b) fine the *National Association* in an amount up to 10.000 Euro. (For purposes of this Rule, any fine paid pursuant to Rule 12.3.2 shall be credited against any fine assessed.)

**12.3.1.1** If four or more violations of these Anti-Doping Rules (other than violations involving Articles 2.4 and 10.3) are committed in addition to the violations described in Article 12.3.1 by *Drivers* or other *Persons* affiliated with a *National Association* within a 12-month period in testing conducted by U.I.M. or Anti-Doping Organizations other than the *National Association* or its *National Anti-Doping Organization*, then the U.I.M. may suspend that *National Association's* membership for a period of up to 4 years.]

**12.3.2** More than one *Driver* or other *Person* from a *National Association* commits an *Anti-Doping Rule* violation during an *International Event*. [In such event U.I.M. may fine that *National Association* in an amount up to 10.000 Euro.]

**12.3.3** A *National Association* has failed to make diligent efforts to keep U.I.M. informed about a *Driver's* whereabouts after receiving a request for that information from U.I.M. [In such event U.I.M. may fine the *National Association* in an amount up to 10.000 Euro per *Driver* in addition to all of U.I.M. costs incurred in *Testing* that *National Association's Drivers*.]

## ARTICLE 13 APPEALS

### 13.1 Decisions Subject to Appeal

Decisions made under these Anti-Doping Rules may be appealed as set forth below in Article 13.2 through 13.4 or as otherwise provided in these Anti-Doping Rules. Such decisions shall remain in effect while under appeal unless the appellate body orders otherwise. Before an appeal is commenced, any post-decision review authorized in these rules must be exhausted (except as provided in Article 13.1.1).

#### 13.1.1 WADA Not Required to Exhaust Internal Remedies

Where *WADA* has a right to appeal under Article 13 and no other party has appealed a final decision within the U.I.M. or its *National Association's* process, *WADA* may appeal such decision directly to *CAS* without having to exhaust other remedies in the U.I.M. or its *National Association's* process.

*[Comment to Article 13.1.1: Where a decision has been rendered before the final stage of U.I.M.'s process (for example, a first hearing) and no party elects to appeal that decision to the next level of U.I.M.'s process (e.g., the Managing Board), then WADA may bypass the remaining steps in U.I.M.'s internal process and appeal directly to CAS.]*

### 13.2 Appeals from Decisions Regarding *Anti-Doping Rule* Violations, Consequences, and *Provisional Suspensions*



A decision that an anti-doping rule violation was committed, a decision imposing *Consequences* for an anti-doping rule violation, or a decision that no anti-doping rule violation was committed; a decision that an anti-doping rule violation proceeding cannot go forward for procedural reasons (including, for example, prescription); a decision under Article 10.10.2 (prohibition of participation during *Ineligibility*); a decision that the U.I.M. or its *National Association* lacks jurisdiction to rule on an alleged anti-doping rule violation or its *Consequences*; a decision by any *National Association* not to bring forward an *Adverse Analytical Finding* or an *Atypical Finding* as an anti-doping rule violation, or a decision not to go forward with an anti-doping rule violation after an investigation under Article 7.4; [and a decision to impose a *Provisional Suspension* as a result of a *Provisional Hearing* or otherwise in violation of Article 7.4] may be appealed exclusively as provided in this Article 13.2. [Notwithstanding any other provision herein, the only *Person* that may appeal from a *Provisional Suspension* is the *Driver* or other *Person* upon whom the *Provisional Suspension* is imposed.]

### **13.2.1 Appeals Involving *International-Level Drivers***

In cases arising from competition in an *International Event* or in cases involving *International-Level Drivers*, the decision may be appealed exclusively to CAS in accordance with the provisions applicable before such court.

*[Comment to Article 13.2.1: CAS decisions are final and binding except for any review required by law applicable to the annulment or enforcement of arbitral awards.]*

### **13.2.2 Appeals Involving National-Level *Drivers***

In cases involving *Drivers* who do not have a right to appeal under Article 13.2.1, each *National Association* shall have in place an appeal procedure that respects the following principles: a timely hearing, a fair and impartial hearing panel; the right to be represented by a counsel at the person's expense; and a timely, written, reasoned decision. U.I.M.'s rights of appeal with respect to these cases are set forth in Article 13.2.3 below.

*[Comment to Article 13.2.2: U.I.M. may elect to comply with this Article by giving its national-level Drivers the right to appeal directly to CAS.]*

### **13.2.3 Persons Entitled to Appeal**

In cases under Article 13.2.1, the following parties shall have the right to appeal to CAS: (a) the *Driver* or other *Person* who is the subject of the decision being appealed; (b) the other party to the case in which the decision was rendered; (c) U.I.M. and any other *Anti-Doping Organization* under whose rules a sanction could have been imposed; (d) the International Olympic Committee or International Paralympic Committee, as applicable, where the decision may have an effect in relation to the Olympic Games or Paralympic Games, including decisions affecting eligibility for the Olympic Games or Paralympic Games; and (e) *WADA*. In cases under Article 13.2.2, the parties having the right to appeal to the national-level reviewing body shall be as provided in the *National Association's* rules but, at a minimum, shall include the following parties: (a) the *Driver* or other *Person* who is the subject of the decision being appealed; (b) the other party to the case in which the decision was rendered; (c) U.I.M.; and (d) *WADA*. For cases under Article 13.2.2, *WADA* and U.I.M. shall also have the right to appeal to CAS with respect to the decision of the national-level reviewing body.

### **13.3 Failure to Render a Timely Decision by U.I.M. and its National Associations**

Where, in a particular case, U.I.M. or its *National Associations* fail to render a decision with respect to whether an anti-doping rule violation was committed within a reasonable deadline set by *WADA*, *WADA* may elect to appeal directly to *CAS* as if U.I.M. or its *National Associations* had rendered a decision finding no anti-doping rule violation. If the *CAS* panel determines that an anti-doping rule violation was committed and that *WADA* acted reasonably in electing to appeal directly to *CAS*, then *WADA's* costs and attorneys fees in prosecuting the appeal shall be reimbursed to *WADA* by U.I.M. or its *National Associations*.

*[Comment to Article 13.3: Given the different circumstances of each anti-doping rule violation investigation and results management process, it is not feasible to establish a fixed time period for U.I.M. to render a decision before WADA may intervene by appealing directly to CAS. Before taking such action, however, WADA will consult with U.I.M. and give U.I.M. an opportunity to explain why it has not yet rendered a decision. Nothing in this rule prohibits U.I.M. from also having rules which authorize it to assume jurisdiction for matters in which the results management performed by one of its National Associations has been inappropriately delayed.]*

#### **13.4 Appeals from Decisions Granting or Denying a Therapeutic Use Exemption**

Decisions by WADA reversing the grant or denial of a TUE may be appealed exclusively to CAS by the *Driver*, U.I.M., or *National Anti-Doping Organization* or other body designated by a *National Association* which granted or denied the exemption. Decisions to deny TUE's, and which are not reversed by WADA, may be appealed by *International-Level Drivers* to CAS and by other *Drivers* to the national level reviewing body described in Article 13.2.2. If the national level reviewing body reverses the decision to deny a TUE, that decision may be appealed to CAS by WADA.

When U.I.M., *National Anti-Doping Organizations* or other bodies designated by *National Associations* fail to take action on a properly submitted TUE application within a reasonable time, their failure to decide may be considered a denial for purposes of the appeal rights provided in this Article.

#### **13.5 Appeal from Decisions Pursuant to Article 12**

Decisions by U.I.M. pursuant to Article 12 may be appealed exclusively to CAS by the *National Association*.

#### **13.6 Time for Filing Appeals**

The time to file an appeal to CAS shall be twenty-one (21) days from the date of receipt of the decision by the appealing party. The above notwithstanding, the following shall apply in connection with appeals

filed by a party entitled to appeal but which was not a party to the proceedings having lead to the decision subject to appeal:

a) Within ten (10) days from notice of the decision, such party/ies shall have the right to request from the body having issued the decision a copy of the file on which such body relied;

b) If such a request is made within the ten-day period, then the party making such request shall have twenty-one (21) days from receipt of the file to file an appeal to CAS.

The above notwithstanding, the filing deadline for an appeal or intervention filed by *WADA* shall be the later of:

(a) Twenty-one (21) days after the last day on which any other party in the case could have appealed, or

(b) Twenty-one (21) days after *WADA's* receipt of the complete file relating to the decision.

## **ARTICLE 14 NATIONAL ASSOCIATIONS' INCORPORATION OF U.I.M. RULES, REPORTING AND RECOGNITION**

### **14.1 Incorporation of U.I.M. Anti-Doping Rules**

All *National Associations* shall comply with these Anti-Doping Rules. These Anti-Doping Rules shall also be incorporated either directly or by reference into each *National Associations* Rules. All *National Associations* shall include in their regulations the procedural rules necessary to effectively implement these Anti-Doping Rules. Each *National Association* shall obtain the written acknowledgement and agreement, in the form attached as Appendix 2, of all *Drivers* subject to *Doping Control* and *Driver Support Personnel* for such *Drivers*. Notwithstanding whether or not the required form has been signed, the Rules of each *National Association* shall specifically provide that all *Drivers*, *Driver Support Personnel* and other *Persons* under the jurisdiction of the *National Association* shall be bound by these Anti-Doping Rules.

## 14.2 Statistical Reporting

**14.2.1** *National Associations* shall report to U.I.M. at the end of every year results of all *Doping Controls* within their jurisdiction sorted by *Driver* and identifying each date on which the *Driver* was tested, the entity conducting the test, and whether the test was *In-Competition* or *Out-of-Competition*. U.I.M. may periodically publish *Testing* data received from *National Associations* as well as comparable data from *Testing* under U.I.M.'s jurisdiction.

**14.2.2** U.I.M. shall publish annually a general statistical report of its Doping Control activities during the calendar year with a copy provided to WADA.

## 14.3 Doping Control Information Clearinghouse

When a *National Association* has received an *Adverse Analytical Finding* on one of its *Drivers* it shall report the following information to U.I.M. and WADA within fourteen (14) days of the process described in Article 7.1.2 and 7.1.3: the *Driver's* name, country, sport and discipline within the sport, whether the test was *In-Competition* or *Out-of-Competition*, the date of *Sample* collection and the analytical result reported by the laboratory. The *National Association* shall also regularly update U.I.M. and WADA on the status and findings of any review or proceedings conducted pursuant to Article 7 (*Results Management*), Article 8 (*Right to a Fair Hearing*) or Article 13 (*Appeals*), and comparable information shall be provided to U.I.M. and WADA within 14 days of the notification described in Article 7.1.9, with respect to other violations of these Anti-Doping Rules. In any case in which the period of *Ineligibility* is eliminated under Article 10.5.1 (*No Fault or Negligence*) or reduced under Article 10.5.2 (*No Significant Fault or Negligence*), U.I.M. and WADA shall be provided with a written reasoned decision explaining the basis for the elimination or reduction. Neither U.I.M. nor WADA shall disclose this information beyond those persons within their organisations with a need to know until the *National Association* has made public disclosure or has failed to make public disclosure as required in Article 14.4 below.

## **14.4 Public Disclosure**

**14.4.1** Neither U.I.M. nor its *National Association* shall publicly identify *Drivers* whose *Samples* have resulted in *Adverse Analytical Findings*, or who were alleged to have violated other Articles of these Anti-Doping Rules until it has been determined in a hearing in accordance with Article 8 that an anti-doping rule violation has occurred, or such hearing has been waived, or the assertion of an anti-doping rule violation has not been timely challenged or the *Driver* has been *Provisionally Suspended*. Once a violation of these Anti-Doping Rules has been established, it shall be publicly reported within 20 days. U.I.M. or its *National Association* must also report within 20 days appeal decisions on an anti-doping rule violation. U.I.M. or its *National Association* shall also, within the time period for publication, send all hearing and appeal decisions to WADA.

**14.4.2** In any case where it is determined, after a hearing or appeal, that the *Driver* or other *Person* did not commit an anti-doping rule violation, the decision may be disclosed publicly only with the consent of the *Driver* or other *Person* who is the subject of the decision. U.I.M. or its *National Association* shall use reasonable efforts to obtain such consent, and U.I.M. consent is obtained, shall publicly disclose the decision in its entirety or in such redacted form as the *Driver* or other *Person* may approve.

**14.4.3** Neither U.I.M. nor its *National Association* or WADA accredited laboratory, or official of either, shall publicly comment on the specific facts of a pending case (as opposed to general description of process and science) except in response to public comments attributed to the *Driver*, other *Person* or their representatives.

## **14.5 Recognition of Decisions by U.I.M. and National Associations**

Any decision of U.I.M. or a *National Association* regarding a violation of these Anti-Doping Rules shall be recognized by all *National Associations*, which shall take all necessary action to render such results effective.

## **ARTICLE 15 RECOGNITION OF DECISIONS BY OTHER ORGANISATIONS**

Subject to the right to appeal provided in Article 13, the *Testing*, TUE's and hearing results or other final adjudications of any *Signatory* to the *Code* which are consistent with the *Code* and are within the *Signatory's* authority, shall be recognized and respected by U.I.M. and its *National Associations*. U.I.M. and its *National Associations* may recognize the same actions of other bodies which have not accepted the *Code* if the rules of those bodies are otherwise consistent with the *Code*.

*[Comment to Article 15: Where the decision of a body that has not accepted the Code is in some respects Code compliant and in other respects not Code compliant, U.I.M. or its National Association should attempt to apply the decision in harmony with the principles of the Code. For example, if in a process consistent with the Code a non-Signatory has found a Driver to have committed an anti-doping rule violation on account of the presence of a Prohibited Substance in his body but the period of Ineligibility applied is shorter than the period provided for in the Code, then U.I.M. or its National Association should recognize the finding of an anti-doping rule violation and they should conduct a hearing consistent with Article 8 to determine whether the longer period of Ineligibility provided in the Code should be imposed.]*

## **ARTICLE 16 STATUTE OF LIMITATIONS**

No action may be commenced under these Anti-Doping Rules against a *Driver* or other *Person* for a violation of an anti-doping rule contained in these Anti-Doping Rules unless such action is commenced within eight years from the date the violation occurred.

## **ARTICLE 17 U.I.M. COMPLIANCE REPORTS TO WADA**

The U.I.M. will report to WADA on the U.I.M.'s compliance with the *Code* every second year and shall explain reasons for any noncompliance.

## ARTICLE 18 AMENDMENT AND INTERPRETATION OF ANTI-DOPING RULES

**18.1** These Anti-Doping Rules may be amended from time to time by the *U.I.M.* Executive.

**18.2** Except as provided in Article 18.5, these Anti-Doping Rules shall be interpreted as an independent and autonomous text and not by reference to existing law or statutes.

**18.3** The headings used for the various Parts and Articles of these Anti-Doping Rules are for convenience only and shall not be deemed part of the substance of these Anti-Doping Rules or to affect in any way the language of the provisions to which they refer.

**18.4** The INTRODUCTION and the APPENDIX I DEFINITIONS shall be considered integral parts of these Anti-Doping Rules.

**18.5** These Anti-Doping Rules have been adopted pursuant to the applicable provisions of the *Code* and shall be interpreted in a manner that is consistent with applicable provisions of the *Code*. The comments annotating various provisions of the *Code* may, where applicable, assist in the understanding and interpretation of these Anti-Doping Rules.

**18.6** Notice to a Driver or other *Person* who is a member of a *National Association* may be accomplished by delivery of the notice to the *National Association*.

**18.7** These Anti-Doping Rules shall come into full force and effect on 1 January 2009 (the “**Effective Date**”). They shall not apply retrospectively to matters pending before the Effective Date; provided, however, that:

**18.7.1** Any case pending prior to the Effective Date, or brought after the Effective Date based on an anti-doping rule violation that occurred prior to the Effective Date, shall be governed by the predecessor to these Anti-Doping Rules in force at the time of the anti-doping rule violation, subject to any application of the principle of *lex mitior* by the hearing panel determining the case.



**18.7.2** Any Article 2.4 whereabouts violation (whether a filing failure or a missed test) declared by U.I.M. under rules in force prior to the Effective Date that has not expired prior to the Effective Date and that would qualify as a whereabouts violation under Article 11 of the *International Standard for Testing* shall be carried forward and may be relied upon, prior to expiry, as one of the three Filing Failures and/or Missed Tests giving rise to an anti-doping rule violation under Article 2.4 of these Anti-Doping Rules. [Note: where existing whereabouts violations are carried over to the new regime, any restrictions under the old rules on combining those whereabouts violations with other whereabouts violations must also be carried over. Hence:] Unless otherwise stated by U.I.M., however:

- a. a filing failure that is carried forward in this manner may only be combined with (post-Effective Date) Filing Failures;
- b. a missed test that is carried forward in this manner may only be combined with (post-Effective Date) Missed Tests; and
- c. a filing failure or missed test declared by any Anti-Doping Organization other than [U.I.M. and a National Association] prior to the Effective Date may not be combined with any Filing Failure or Missed Test declared under these Anti-Doping Rules.]

**18.7.3** Where a period of *Ineligibility* imposed by U.I.M. under rules in force prior to the Effective Date has not yet expired as of the Effective Date, the *Person* who is *Ineligible* may apply to U.I.M. for a reduction in the period of *Ineligibility* in light of the amendments made to the *Code* as from the Effective Date. To be valid, such application must be made before the period of *Ineligibility* has expired.

**18.7.4** Subject always to Article 10.7.5, anti-doping rule violations committed under rules in force prior to the Effective Date shall be taken into account as prior offences for purposes of determining sanctions under Article 10.7. Where such pre-Effective Date anti-doping rule violation involved a substance that would be treated as a Specified Substance under these Anti-Doping Rules, for which a period of *Ineligibility* of less than two years was imposed, such violation shall be considered a Reduced Sanction violation for purposes of Article 10.7.1.

## APPENDIX 1 - Definitions

Adverse Analytical Finding. A report from a laboratory or other approved *Testing* entity that identifies in a *Sample* the presence of a *Prohibited Substance* or its *Metabolites* or *Markers* (including elevated quantities of endogenous substances) or evidence of the *Use* of a *Prohibited Method*.

Anti-Doping Organization. A *Signatory* that is responsible for adopting rules for initiating, implementing or enforcing any part of the *Doping Control* process. This includes, for example, the International Olympic Committee, the International Paralympic Committee, other *Major Event Organizations* that conduct *Testing* at their *Events*, WADA, InterNational Associations, and *National Anti-Doping Organizations*.

Driver. Any *Person* who participates in sport at the international level (as defined by each International Association), the national level (as defined by each *National Anti-Doping Organization*, including but not limited to those *Persons* in its *Registered Testing Pool*), and any other competitor in sport who is otherwise subject to the jurisdiction of any *Signatory* or other sports organization accepting the *Code*. All provisions of the *Code*, including, for example, *Testing*, and TUE's must be applied to international and national-level competitors. Some *National Anti-Doping Organizations* may elect to test and apply anti-doping rules to recreational-level or masters competitors who are not current or potential national caliber competitors. *National Anti-Doping Organizations* are not required, however, to apply all aspects of the *Code* to such *Persons*. Specific national rules may be established for Doping Control for non-international-level or national-level competitors without being in conflict with the *Code*. Thus, a country could elect to test recreational-level competitors but not require TUE's or whereabouts information. In the same manner, a *Major Event Organization* holding an *Event* only for masters-level competitors could elect to test the competitors but not require advance TUE or whereabouts information. For purposes of Article 2.8 (Administration or *Attempted Administration*) and for purposes of anti-doping information and education, any *Person* who participates in sport under the authority of any *Signatory*, government, or other sports organization accepting the *Code* is a *Driver*.

*[Comment to Driver: This definition makes it clear that all international and national-caliber Drivers are subject to the anti-doping rules of the Code, with the precise definitions of international and national level sport to be set forth in the anti-doping rules of the U.I.M. and National Anti-Doping Organizations, respectively. At the national level, anti-doping rules adopted pursuant to the Code shall apply, at a minimum, to all persons on national teams and all persons qualified to compete in any national championship in any sport. That does not mean, however, that all such Drivers must be included in a National Anti-Doping Organization's Registered Testing Pool. The definition also allows each National Anti-Doping Organization, if it chooses to do so, to expand its anti-doping control program beyond national-caliber Drivers to competitors at lower levels of competition. Competitors at all levels of competition should receive the benefit of anti-doping information and education.]*

*Driver Support Personnel*. Any coach, trainer, manager, agent, team staff, official, medical, paramedical personnel, parent or any other *Person* working with, treating or assisting a Driver participating in or preparing for sports *Competition*.

*Attempt*. Purposely engaging in conduct that constitutes a substantial step in a course of conduct planned to culminate in the commission of an anti-doping rule violation. Provided, however, there shall be no anti-doping rule violation based solely on an *Attempt* to commit a violation if the *Person* renounces the attempt prior to it being discovered by a third party not involved in the *Attempt*.

*Atypical Finding*. A report from a laboratory or other WADA-approved entity which requires further investigation as provided by the *International Standard for Laboratories* or related Technical Documents prior to the determination of an *Adverse Analytical Finding*.

*CAS*. The Court of Arbitration for Sport.

*Code*. The World Anti-Doping Code.

*Competition*. A single race, match, game or singular athletic contest. For example, a basketball game or the finals of the Olympic 100-meter dash in athletics. For stage races and other athletic contests where prizes are

awarded on a daily or other interim basis the distinction between a *Competition* and an *Event* will be as provided in the rules of the applicable International Association.

*Consequences of anti-doping rule violations.* A Driver's or other Person's violation of an anti-doping rule may result in one or more of the following: (a) *Disqualification* means the Driver's results in a particular *Competition* or *Event* are invalidated, with all resulting consequences including forfeiture of any medals, points and prizes; (b) *Ineligibility* means the Driver or other Person is barred for a specified period of time from participating in any *Competition* or other activity or funding as provided in Article 10.9; and (c) *Provisional Suspension* means the Driver or other Person is barred temporarily from participating in any *Competition* prior to the final decision at a hearing conducted under Article 8 (Right to a Fair Hearing).

*Disqualification.* See *Consequences of anti-doping rule violations*, above.

*Doping Control.* All steps and processes from test distribution planning through to ultimate disposition of any appeal including all steps and processes in between such as provision of whereabouts information, sample collection and handling, laboratory analysis, TUE's, results management and hearings.

*Event.* A series of individual *Competitions* conducted together under one ruling body (e.g., the Olympic Games, FINA World Championships, or Pan American Games).

*Event Period.* The time between the beginning and end of an *Event*, as established by the ruling body of the *Event*.

*In-Competition.* Unless provided otherwise in the rules of an International Association or other relevant *Anti-Doping Organization*, "*In-Competition*" means the period commencing twelve hours before a *Competition* in which the Driver is scheduled to participate through the end of such *Competition* and the *Sample* collection process related to such *Competition*.

*Independent Observer Program.* A team of observers, under the supervision of WADA, who observe and may provide guidance on the

*Doping Control* process at certain *Events* and report on their observations.

*Individual Sport*. Any sport that is not a *Team Sport*.

*Ineligibility*. See *Consequences of Anti-Doping Rule Violations* above.

*International Event*. An *Event* where the International Olympic Committee, the International Paralympic Committee, an International Association, a *Major Event Organization*, or another international sport organization is the ruling body for the *Event* or appoints the technical officials for the *Event*.

*International-Level Driver*. *Driver* designated by one or more International Associations as being within the *Registered Testing Pool* for an International Association.

*International Standard*. A standard adopted by WADA in support of the *Code*. Compliance with an *International Standard* (as opposed to another alternative standard, practice or procedure) shall be sufficient to conclude that the procedures addressed by the *International Standard* were performed properly. *International Standards* shall include any Technical Documents issued pursuant to the *International Standard*.

*Major Event Organizations*. The continental associations of *National Olympic Committees* and other international multi-sport organizations that function as the ruling body for any continental, regional or other *International Event*.

*Marker*. A compound, group of compounds or biological parameter(s) that indicates the *Use of a Prohibited Substance or Prohibited Method*.

*Metabolite*. Any substance produced by a biotransformation process.

*Minor*. A natural *Person* who has not reached the age of majority as established by the applicable laws of his or her country of residence.

*National Anti-Doping Organization*. The entity(ies) designated by each country as possessing the primary authority and responsibility to adopt and implement anti-doping rules, direct the collection of *Samples*, the management of test results, and the conduct of hearings, all at the national level. This includes an entity which may be designated by

multiple countries to serve as regional *Anti-Doping Organization* for such countries. If this designation has not been made by the competent public authority(ies), the entity shall be the country's *National Olympic Committee* or its designee.

*National Event.* A sport *Event* involving international or national-level *Drivers* that is not an *International Event*.

*National Association.* A national or regional entity which is a member of or is recognized by U.I.M. as the entity governing the U.I.M.'s sport in that nation or region.

*National Olympic Committee.* The organization recognized by the International Olympic Committee. The term *National Olympic Committee* shall also include the National Sport Confederation in those countries where the National Sport Confederation assumes typical *National Olympic Committee* responsibilities in the anti-doping area.

*No Advance Notice.* A *Doping Control* which takes place with no advance warning to the *Driver* and where the *Driver* is continuously chaperoned from the moment of notification through *Sample* provision.

*No Fault or Negligence.* The *Driver's* establishing that he or she did not know or suspect, and could not reasonably have known or suspected even with the exercise of utmost caution, that he or she had *Used* or been administered the *Prohibited Substance* or *Prohibited Method*.

*No Significant Fault or Negligence.* The *Driver's* establishing that his or her fault or negligence, when viewed in the totality of the circumstances and taking into account the criteria for *No Fault or Negligence*, was not significant in relationship to the anti-doping rule violation.

*Out-of-Competition.* Any *Doping Control* which is not *In-Competition*.

*Participant.* Any *Driver* or *Driver Support Personnel*.

*Person.* A natural *Person* or an organization or other entity.

*Possession.* The actual, physical possession, or the constructive possession (which shall be found only if the person has exclusive control over the *Prohibited Substance/Method* or the premises in which a *Prohibited Substance/Method* exists); provided, however, that if the

person does not have exclusive control over the *Prohibited Substance/Method* or the premises in which a *Prohibited Substance/Method* exists, constructive possession shall only be found if the person knew about the presence of the *Prohibited Substance/Method* and intended to exercise control over it. Provided, however, there shall be no anti-doping rule violation based solely on possession if, prior to receiving notification of any kind that the *Person* has committed an anti-doping rule violation, the *Person* has taken concrete action demonstrating that the *Person* never intended to have possession and has renounced possession by explicitly declaring it to an *Anti-Doping Organization*. Notwithstanding anything to the contrary in this definition, the purchase (including by any electronic or other means) of a *Prohibited Substance* or *Prohibited Method* constitutes possession by the *Person* who makes the purchase.

*[Comment: Under this definition, steroids found in a Driver's car would constitute a violation unless the Driver establishes that someone else used the car; in that event, the Anti-Doping Organization must establish that, even though the Driver did not have exclusive control over the car, the Driver knew about the steroids and intended to have control over the steroids. Similarly, in the example of steroids found in a home medicine cabinet under the joint control of a Driver and spouse, the Anti-Doping Organization must establish that the Driver knew the steroids were in the cabinet and that the Driver intended to exercise control over the steroids.]*

*Prohibited List*. The List identifying the *Prohibited Substances* and *Prohibited Methods*.

*Prohibited Method*. Any method so described on the *Prohibited List*.

*Prohibited Substance*. Any substance so described on the *Prohibited List*.

*Provisional Hearing*. For purposes of Article 7.6, an expedited abbreviated hearing occurring prior to a hearing under Article 8 (Right to a Fair Hearing) that provides the *Driver* with notice and an opportunity to be heard in either written or oral form.

*Provisional Suspension*. See *Consequences* above.

Publicly Disclose or Publicly Report. To disseminate or distribute information to the general public or persons beyond those persons entitled to earlier notification in accordance with Article 14.

Registered Testing Pool. The pool of top level *Drivers* established separately by each InterNational Association and *National Anti-Doping Organization* who are subject to both *In-Competition* and *Out-of-Competition Testing* as part of that InterNational Association's or National Anti-Doping Organization's test distribution plan.

Retroactive TUE. As defined in the *International Standard for Therapeutic Use Exemptions*.

Sample. Any biological material collected for the purposes of *Doping Control*.

*[Comment to Sample: It has sometimes been claimed that the collection of blood samples violates the tenets of certain religious or cultural groups. It has been determined that there is no basis for any such claim.]*

Signatories. Those entities signing the *Code* and agreeing to comply with the *Code*, including the International Olympic Committee, InterNational Associations, International Paralympic Committee, *National Olympic Committees*, National Paralympic Committees, *Major Event Organizations*, *National Anti-Doping Organizations*, and WADA.

Specified Substances. As defined in Article 4.2.2.

Substantial Assistance. For purposes of Article 10.5.3, a *Person* providing *Substantial Assistance* must: (1) fully disclose in a signed written statement all information he or she possesses in relation to anti-doping rule violations, and (2) fully cooperate with the investigation and adjudication of any case related to that information, including, for example, presenting testimony at a hearing if requested to do so by an *Anti-Doping Organization* or hearing panel. Further, the information provided must be credible and must comprise an important part of any case which is initiated or, if no case is initiated, must have provided a sufficient basis on which a case could have been brought.

Tampering. Altering for an improper purpose or in an improper way; bringing improper influence to bear; interfering improperly; obstructing,



misleading or engaging in any fraudulent conduct to alter results or prevent normal procedures from occurring; or providing fraudulent information to an *Anti-Doping Organization*.

*Target Testing*. Selection of *Drivers* for *Testing* where specific *Drivers* or groups of *Drivers* are selected on a non-random basis for *Testing* at a specified time.

*Team Sport*. A sport in which the substitution of players is permitted during a *Competition*.

*Testing*. The parts of the *Doping Control* process involving test distribution planning, *Sample* collection, *Sample* handling, and *Sample* transport to the laboratory.

*Trafficking*. Selling, giving, transporting, sending, delivering or distributing a *Prohibited Substance* or *Prohibited Method* (either physically or by any electronic or other means) by a *Driver*, *Driver Support Personnel* or any other *Person* subject to the jurisdiction of an *Anti-Doping Organization* to any third party; provided, however, this definition shall not include the actions of bona fide medical personnel involving a *Prohibited Substance* used for genuine and legal therapeutic purposes or other acceptable justification, and shall not include actions involving *Prohibited Substances* which are not prohibited in *Out-of-Competition Testing* unless the circumstances as a whole demonstrate such *Prohibited Substances* are not intended for genuine and legal therapeutic purposes.

*TUE*. As defined in Article 2.6.1.

*TUE Panel*. As defined in Article 4.4.3.

*UNESCO Convention*. The International Convention against Doping in Sport adopted by the 33<sup>rd</sup> session of the UNESCO General Conference on 19 October 2005 including any and all amendments adopted by the States Parties to the Convention and the Conference of Parties to the International Convention against Doping in Sport.

*Use*. The utilization, application, ingestion, injection or consumption by any means whatsoever of any *Prohibited Substance* or *Prohibited Method*.

*WADA*. The World Anti-Doping Agency.

**APPENDIX 2 - Acknowledgment and Agreement**

I, as a member of [National Association] and/or a participant in a [National Association or U.I.M.] authorized or recognized event, hereby acknowledge and agree as follows:

1. I have received and had an opportunity to review the U.I.M. Anti-Doping Rules.
2. I consent and agree to comply with and be bound by all of the provisions of the U.I.M. Anti-Doping Rules, including but not limited to, all amendments to the Anti-Doping Rules and all International Standards incorporated in the Anti-Doping Rules.
3. I acknowledge and agree that [National Associations and U.I.M.] have jurisdiction to impose sanctions as provided in the U.I.M. Anti-Doping Rules.
4. I also acknowledge and agree that any dispute arising out of a decision made pursuant to the U.I.M. Anti-Doping Rules, after exhaustion of the process expressly provided for in the U.I.M. Anti-Doping Rules, may be appealed exclusively as provided in Article 13 of the U.I.M. Anti-Doping Rules to an appellate body for final and binding arbitration, which in the case of International-Level Drivers is the Court of Arbitration for Sport.
5. I acknowledge and agree that the decisions of the arbitral appellate body referenced above shall be final and enforceable, and that I will not bring any claim, arbitration, lawsuit or litigation in any other court or tribunal.
6. I have read and understand this Acknowledgement and Agreement.

---

Date

---

Print Name (Last Name, First Name)

---

Date of Birth  
(Day/Month/Year)

---

Signature (or, if a minor, signature of  
legal guardian)

## **101 - U.I.M. EVENT SANCTIONS AND THE SPORTS CALENDAR**

### **101.01 - EVENT SANCTION REQUIREMENTS AND FEES**

***All international powerboating events must be sanctioned by the U.I.M. and by the National Authority. An International Sanction is a written authorization which permits an organizing body to conduct an international event under the rules of the U.I.M.***

***Written approval by the U.I.M. of the registration of an international event on the U.I.M. annual calendar, subject to payment of a fee determined annually by the General Assembly, constitutes the granting of an International U.I.M. Sanction for that event.***

If two titles are organised at one event, the second calendar fee will be invoiced at 50 %.

If three titles are organised at one event, the second calendar fee will be invoiced at 50 % and the third one at 25 %, and the fourth (Water Festival) at 25 %.

Payment of these fees must be made within three months after the fixing of the international calendar except Water Festivals which are due: 50 %, two months after allocation and next 50 %, twelve months before event.

Permission to organise these meetings is only given by the U.I.M. upon payment of these fees.

No permission is to be granted to National Authorities who are in arrears of payment.

All requests to organise an international championship must be sent to the U.I.M. Secretariat before the time set by the deadline in the rules.

The organisation of an event cannot be granted if the title, the classes to race, the registered race course and the date of the event are not given.

The titled meetings have priority over all other meetings before the closing of the registrations for the sports calendar. However, when the

sports calendar is finalised, all the motorboating meetings are on an equal footing.

In order to promote new series and classes, new hulls, motors or engines, new ideas regarding propulsion and new concepts of racing, the Council may, provided the request to organise be accompanied by an amount equal to double the fee of an ordinary meeting, approve the organisation of international contests for such boats, motors or engines, type of propulsion and races of a kind not yet known to the U.I.M. provided such events do not clash with other U.I.M. titled meetings at the sole discretion of U.I.M.

## 101.02 - OTHER MEETINGS

It is forbidden to organise national championships for series and classes which are in the programme of a U.I.M. titled meeting taking place the same day.

The calendar of national or local events is not to be submitted to the U.I.M. The interested National Authorities take responsibility for their own calendar.

No U.I.M. national authority in the same continent shall have an *international* race on its calendar of the same class, as a U.I.M. World or Continental Championship on the same date, based upon dates sanctioned at the U.I.M. General Assembly.

## 101.03 - DEADLINE DATES

International Water Festival events (all dates refer to the year preceding the proposed events)

1 January            Applications from NA for Water Festivals with dates/venues

31 January        Allocation of Water Festivals by Cominsport

Titled events not run in Water Festivals

1 February        List to all NA of remaining titles available

- 1 March: Forwarding of requests for international titled events
- 1 April: Allotting of titled events to NA for the following year
- 15 April Publishing of all U.I.M. circuit title allocation
- 10 September: Forwarding of dates and venues of titled events by the NAs.
- Forwarding of request for ordinary international events, complete with dates and venues.
- November calendar
- Meeting: Drawing-up of the international calendar.
- 15 December: Publishing of the international calendar.

## **101.04 - LATE REQUEST, CHANGE OF DATE AND CANCELLATION**

### **Titled events**

Late request: a late request will be considered only if the title is still vacant or if the title or the event has been cancelled by the NA to whom it was granted or by the U.I.M. If the title is granted, the organiser will pay the normal inscription fee.

Late forwarding of date or venue : the inscription fee will be raised by 50%

Change of date: the inscription fee will be raised by 25 %. The U.I.M. give its assent to the new date. The request for a change of date must be received by the U.I.M. secretariat not less than 90 days before the calendar date. The new date will be approved and announced not less than 30 days after the date on which the request was received.

At less than 90 days before the calendar date, the date cannot be changed. The event will be cancelled or run as an ordinary event, but no part of the calendar fee will be refunded.

Cancellation: if the title or the event is cancelled 90 days or more before the calendar date, 50 % of the inscription fee will be refunded. In a later cancellation there will be no refunding. A cancelled title will be treated like a title not yet requested.

If the titled event is cancelled less than 30 days before the calendar date, the National Authority may not be allowed to organise a titled event the following year.

In all «Water Festival» the following will apply :

- no late requests
- no change of date
- no refund of inscription for cancellation
- no round of the series can be re-allocated except if a complete Water Festival is cancelled before fixing the U.I.M. Calendar at the GA or failure of payment of the relevant fees by the set deadlines. (i.e 12 months before event Rule 101.01)

### **Ordinary events**

Late request: the inscription fee will be raised by 25%.

Change of date: the inscription fee will be raised by 25%.

Cancellation: If the event is cancelled 30 days or more before the calendar date, 50% of the inscription fee will be refunded. In later cancellations there will be no refunding.

## **102 - U.I.M. COMMISSIONER**

### **102.01 - GENERAL**

The presence of a U.I.M. Commissioner is required at any international titled meeting. For F1, two Commissioners are required.

The function of Commissioner must be fulfilled most carefully.

As soon as U.I.M. gets the Commissioner's agreement, the Secretary General of the U.I.M. will send a letter to the National Authority informing them that the Commissioner has been designated for the events referred in the letter.

No commissioner will be appointed to an event organised by his National Authority, unless a derogation agreed by Cominsport.

The U.I.M. Commissioner sent to the competitions must come from a Nation near to the organising one and not from different continents.

National Authorities are requested to send yearly to the U.I.M. Secretariat a list of candidate Commissioners with the following data:

- Name, address, telephone, telefax and/or e-mail
- languages spoken
- languages read and understood
- at what times the candidate is at disposal
- knowledge in sports and technical matters.

## 102.02 - FUNCTIONS

The U.I.M. Commissioner

- assists the local organiser and more particularly the Officer of the Day;
- is a voting member of the international jury;
- ***when there are two Commissioners - only one can vote;***
- approves last minute amendments to the advance-programme;
- ensure that the course is in accordance with the water registration;
- takes part in important decision-making during the race with the Officer of the Day, the Deputy O.O.D. and the 2<sup>nd</sup> Commissioner, if any;
- takes part in urgent decision-making with the Officer of the Day and the organising promoter, in matters related to the overall organisation.

The U.I.M. Commissioner is entitled to take action with the O.O.D. and race organising committee if safety conditions are not met. In some cases, he will even be entitled to request that the event be suspended if safety conditions are not improved.

***If the race is suspended, the U.I.M. ceases to be responsible for any further race/heats and if it is a U.I.M. titled event, then the results will be null and void. Further action may be taken against the relevant National Authority.***

The legality of the fuel is solely under the judgement of the U.I.M. Commissioner, based on all tests made available to him.

#### GUIDELINES for U.I.M. Commissioners

- The commissioner must always be aware that he is the sole representative of U.I.M.

On the day prior to the first race/practise day, a meeting shall be held between the U.I.M. Commissioner and the race organisers/officials, and the promoter (if any) to review all aspects of the race organisation. Time for the meeting will be at 18.00, unless otherwise agreed.

The commissioner should also ask for

- \* programme
- \* list of jury members and National Authority delegates
- \* list of entries with names and nationalities.

- He must meet the O.O.D. and Jury Chairman.
- He must assist the O.O.D. to resolve all race problems.
- He must be present at any driver's meeting.
- He must check and approve the race course to comply with U.I.M. and the advance regulations. ***This must be completed with the O.O.D. and/or Safety Officer and any official Drivers Representative.***



- During the meeting he must keep close contact with O.O.D. and be satisfied that everything is being done correctly according to U.I.M. rules.
- He must ensure a Jury meeting is held promptly and any penalty is imposed according to U.I.M. rules.
- In case of an accident, he must keep all the information on the progress or otherwise of the injured persons and he must send completed U.I.M. accident report form to U.I.M. as soon as possible.
- After completion of the races, he must receive a copy of all classifications and documents to be transferred to U.I.M.
- He should be present at the Technical Inspection of the winning boat.
- He must survey the weighing of the boats (if applicable), or receive the relevant data.
- ***He reserves the right to order the exchange of any relevant ECU/CDI unit with another if supplied by the U.I.M. (see rule 502.04).***
- He must be present at the prize giving.
- ***He shall present any U.I.M. Medals to the winners.***

### **102.03 - AFTER THE RACE**

After the event, he sends his report to the U.I.M. Secretariat by using the official form, within ten days after the race. The official results of the event must be enclosed with the report.

The reports from Commissioners, including accident reports, are to be considered as confidential matter and cannot be used for aims other than U.I.M.'s, not be communicated to the press or otherwise disclosed for any purpose whatsoever.

Should any Commissioner fail to obtain all necessary data and results for transmission to U.I.M., he will note this fact in his report and will urge the

organisers to send all required documents by themselves to the Secretariat of U.I.M., as soon as possible.

A copy of the Commissioner's report will be sent, as soon as possible, by the U.I.M. office to the President of Sport/Technical/Safety Commissions, all members of Cominsport and to the NA of the organiser.

***The report from the organizer (O.O.D.) will be copied only to the President of Cominsport.***

## **102.04 - ACCOMMODATION AND TRAVEL EXPENSES**

The National Authority must remind the organisers that the Commissioner must be accommodated in a good hotel for the whole duration of the event and as long as required by the accomplishment of his mission. The costs of such accommodation are borne by the organisers.

Travel expenses must be compensated by the organisers to the Commissioner from his place of residence to the race venue, calculated upon the basis of a return air ticket, economy class.

If the organisers do not offer daily meals and local transportation to the Commissioner, they must pay him/her up to 30 € per day.

No other costs are to be reimbursed to the Commissioner unless expressly agreed between the organisers and the Commissioner.

Reimbursement shall be done by the organisers directly to the Commissioner prior to departure. If the organisers fail to do so, the Commissioner shall invoice the U.I.M. The U.I.M. then sends the organisers' National Authority an equivalent invoice, adding a 10% surcharge. The invoice must be settled to the U.I.M. within 30 days.

## **103 - RACES RECOGNISED BY THE U.I.M.**

The U.I.M. recognises the following events:

- Titled international events

- Ordinary international events
- International cruises
- National events
- Private or club events

## **104 - NON APPROVED RACES**

Races not organised according to U.I.M. rules are not to be recognised and all officials and drivers who take any part in such races are suspended or excluded if offence recurs.

The same applies to motorboating events not approved by National Authorities.

Any driver having competed in a race not approved by the National Authority of that country or forbidden by the National Authority may be suspended for a period to be fixed by the National Authority.

In the case of an international meeting being organised by a non-affiliated club which has not asked permission to organise such a meeting, the National Authority must:

- notify the organising club that the drivers can be suspended.
- notify the drivers that they will be suspended in their own country if they take part in international races not approved by the National Authority; the latter may request U.I.M. to extend this suspension to other countries.

A national race, or a race by "invitation" in which a foreign driver is invited to take part must be entered on the U.I.M. Calendar otherwise it becomes an unauthorised event. Invited drivers entering such unauthorised races, may lose their international licences. Remember that drivers having international licences, are only allowed to enter a meeting outside their country provided their National Authority gives them permission to do so.

## **105 - TITLED INTERNATIONAL EVENTS**

There are six categories of titled event:

- World Championship events,
- World Cup events,
- Continental Championship events,
- Continental Cup events,
- Grand Prix events,
- International Water Festival events.

Note : Water Festival events in 2011 must include the following : F125, F250 and/or F350, **F500**. All being part of the class series.

There can be one World Cup and Continental Cup event per class and per year, provided that a World or Continental Championship is not organised for the class in question.

There can be only one Grand Prix event per country and per year, except when a World Championship series race takes place in that country

Additional classification, title and awards for low emission entrants within all classes S, T, P, PR and F4 titled events. Same classes must race together to qualify for these U.I.M. titles. A minimum number of starters must be 3. The intent is to award U.I.M. titles to only low emission engine competitors, when the results of the classification of a titled event results in more than 50 % low emission engines. Implementation will only be in that class and will only commence one year later. (i.e. + 50 % **in 2009** then ALL low emission engines **in 2011**).

No meeting is allowed a title unless authorised to do so by the U.I.M. who draw up the annual list in the official calendar.

Except for Formula Future **and American Power Boat Association classes**, if a scheduled U.I.M. titled event takes place with only **5** or less participating boats from less than 2 National Authorities only the event results will stand. It will not be officially recognised by the U.I.M. and therefore not included in the U.I.M. records. The organiser has the

discretion to pay any prize and/or travel/start monies. The organizer will receive a credit of 50 % of the calendar fee. ***In the event of endurance titles awarded as a result of a series of (more than one) races, the participant boats in all events may be counted to comply with the minimum participation number.***

Water Festivals include “O” classes 125/250 **and/or** 350 under Series rules and 500 (500 under F500 rules). NA’s application has absolute priority over any other application within these classes (rule 101.03). The U.I.M. still accepts single title events.

U.I.M. aims to protect titled meetings, the Council may refuse to sanction any meeting which takes place at the same time. Such refusal is only notified at the specific request of the National Authority lodging a protest.

## **106 - INTERNATIONAL CHAMPIONSHIPS, WORLD AND CONTINENTAL CUPS**

### **106.01- GENERAL RULES**

World Championships are open to all U.I.M. classes as well as all A.P.B.A. classes. There can be only one World Championship per class, per year. The requests to organise these championship must be sent in due time. The Sports Commission will allocate the Championships.

No exception is to be allowed to the preceding rule.

U.I.M. has created Formula World Championships for the F1, F2, F500, **F4** and Formula European Championships for F250, F1000, Formula R 1000, F125 and F350. All to be run as a series.

Classes O125 to O700 U.I.M. World and Continental championships, these events will only be granted permission by Cominsport on a venue within the U.I.M. venue listings agreed by Cominsport.

MINIMUM criteria for U.I.M. race Course/Venues:

ONLY for allocation of classes “O” up to O700

The following are mandatory:

- 1) Minimum number of boats registered to be raced at one time: 14,
- 2) No clock start,
- 3) Correct length and width of jetty. Must be very stable to take relevant boats for safe launching,
- 4) Organisation to guarantee:
  - a) Full medical rescue as U.I.M. rules,
  - b) Full experienced organisation to U.I.M. rules,
  - c) Computerised timing equipment and experienced staff,
  - d) Adequately controlled pit area on hard surface,
  - e) Adequate toilets and showers (hot).

Other points to be added on experience.

The U.I.M. delivers following requests made by the champions to their National Authorities and transmitted by that National Authority to the U.I.M. Secretariat a “champion’s certificate”.

The cost of such certificate is fixed annually by the General Assembly and is to be paid by the National Authority to the U.I.M. when the request is made.

A list of champions is issued annually.

The U.I.M. rules and those of the National Authority are applicable for any point not foreseen by these rules.

A non-European may be proclaimed European Champion provided he has had a European licence for more than two years. The same applies for other continents.

A non-European driver can only compete in any U.I.M. European titled event if:

- a) It is a series,

- b) He/she competes on equal terms for any start/prize monies and/or event trophies,
- c) He will not accumulate points for the Series,
- d) His results will be discounted when calculating points to go forward to the final series point count.

Immediately after the Championship, the name of the Champion must be transmitted by fax and/or e-mail to the U.I.M. secretariat.

The entry for the drivers is free of charge.

## 106.02 - WATER REGISTRATION

Permission to organise **a U.I.M. titled race meeting** is granted ONLY if the race is run on a course approved by the National Authority and registered by the U.I.M.

All the National Authorities MUST approve such courses and send a list (updated every four years) to the U.I.M. Every list must include ALL the following criteria in English:

A PLAN to scale (1:500 ... 1:2 000) with graphic scale representation and geographical north, showing accurately:

- a) The minimum depth of the race course,
- b) Position of ALL race buoys,
- c) Position of finish line,
- d) Position of jetty/beach (if applicable) or start line,
- e) Direction of the race course,
- f) Other obstructions duly marked,
- g) Any other buoys not applicable to the race,
- h) Position of control,
- i) Entry to water... crane/slipway,

- j) Area for pits,
- k) Spectator barriers etc. (see drawing),
- l) Position of ambulance and CLEAR access,
- m) An ALTERNATIVE race course (if possible) only for use under “Force Majeure” conditions,
- n) Altitude of venues,
- o) Coloured photographs of the surrounding area (banks, sea walls and others),
- p) Tides chart of the relevant race days,
- q) Categories to race,
- r) Number of boats of each class/category to race,
- s) Position of sound level meter.

List of all possible Classes allowed to race. List MAXIMUM number of boats allowed to race in each class.

For circuit races, bridges in the circuit should be avoided. If unavoidable, minimum opening clearances must be 50 m width for hydros, 80 m width for other classes and 15 m vertical clearance, except for endurance races.



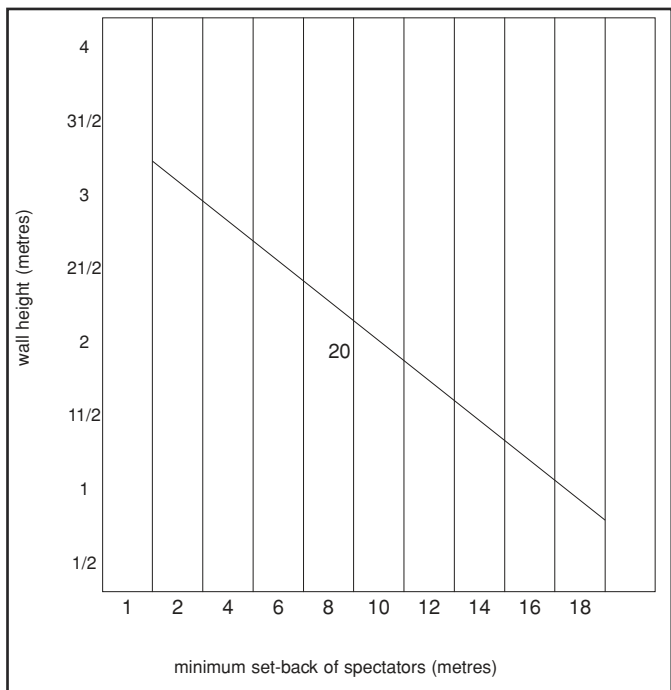

#### QUESTIONNAIRE FOR WATER REGISTRATION - ARTICLE 106.02

This request will only be considered valid if a plan to scale is added with all details as requested under rule 106.02.

Please provide : A plan in two-fold of the venue with graphic scale - A3 color copy - photographs of the banks and or others of interest by February 28<sup>th</sup> the latest or 90 days prior to the race.

Please refer also to rules 106.01, 302.01, 307.01, 307.02, 313.03 and those on the blue pages section of the "U.I.M. Circuit Rules" book when applicable.

COUNTRY :

PLACE :

NATURE OF WATER :

TOTAL LENGTH OF CIRCUIT :

NUMBER OF BUOYS :

DESCRIPTION OF TURNING BUOYS :

MINIMUM DEPTH OF CIRCUIT : Jetty Race course:

MINIMUM WIDTH OF RACE COURSE :

HEIGHT OF THE BANKS :

ENTRY TO WATER :

PLACE AVAILABLE FOR PUBLIC :

PROTECTION OF PUBLIC :

ALTITUDE OF VENUE :

CATEGORIES TO RACE :

NUMBER OF BOATS TO RACE :

N.A. STAMP Registered on : U.I.M. STAMP

Registered for :

Registration n° :

## **107 - WORLD CHAMPIONSHIP**

World Championships, allocated by the U.I.M. Sports Commission are raced under the same rules as the Continental Championships.

To avoid any confusion about the value of the title, there will be no class World Championship when such Championship is organised under the Formula system.

## **108 - CONTINENTAL AND WORLD CHAMPIONSHIPS**

### **108.01 - NUMBER OF CHAMPIONSHIPS**

There can be one championship per year, per class, per continent (except where there is a series) but only in classes approved by the Sports Commission at least 13 months before the applicable year.

The right to organise Continental and World Championships is annually rotated in alphabetical order of the Initials of the English names of the affiliated countries applying. However, when National Authorities apply for a Water Festival, no rotation will be used.

***In 2011, a water festival can include 3 or 4 classes.***

***A Water Festival with 4 classes must include a round of the following series for the European Championships F125, F250, F350 and F500 for the World Series.***

***A Water Festival with 3 classes must include a round of the following series for the European Championships F125 and F250 or F350, and F500 for the World Series.***

Each application will be judged by Cominsport solely on the presentation of the merits of the actual organiser, venue, facilities, date/time of year, previous record and input from the Cominsport hydroplane working group. No limit to the number of Water Festivals allocated to one National Authority.

If a nation declines to organise a championship the next in rotation is taken into consideration.

If a country is allocated a U.I.M. title for a certain year but fails to organise it, this country is considered as having held the championship as far as rotation is concerned.

## 108.02 - EUROPEAN CHAMPIONSHIP SERIES

European Championships are a series. The following classes will be included in Water Festivals :

- O 125 Formula 125                   (4 races - **4 heats**)
- O 250 Formula 250                   (4 races - **4 heats**)
- O 350 Formula 350                   (4 races - **4 heats**)

Other classes :

- FR 1000 Formula R 1000 (up to 4 races series)

Each leg of the Championships should be run in accordance to U.I.M. 108 rule.

Classification: In order to obtain a general classification of the European Championship, the first driver classified will be given points as follows: 20/17/15 ... (see F500 - rule 3).

If there any dispute of how the above rule, guidance should be taken from:

- 1) the F500 rules,
- 2) the U.I.M. ordinary rules.

U.I.M. will provide medals for 1-2-3 in the series at the final race.

Foreign drivers, based on the nationality of their international licence: Those drivers who successfully start in either a qualifying heat & race must receive the following **travel** money:

- |               |           |
|---------------|-----------|
| Formula R1000 | Euros 100 |
| Formula 250   | Euros 160 |

Formula 125          Euros 160

Formula 350          Euros 160

If a driver participates in more than one class at a multi-series event, the organisers have the option of only paying for one entry, if mentioned in the advance program. ***If the relevant classes have different start monies the organizers must pay the higher.***

### **108.03 - ENTRIES**

Each National Authority may designate drivers according to its own rules.

Entries are to be sent through their National Authority to the organiser, no later than **28** days, before the start of the meeting. Failure to meet this deadline may result in the driver losing any scheduled start money.

### **108.04 - HEATS AND LENGTH**

A championship can only be held during an International meeting. The race must include four heats. Every heat must have a length of:

6 to 8 km for the class OSY 400, JT 250, T250, GT15, GT30, O 125, O 175,

12 to 17 km for racing outboards 250cc to 700 cc  
                   for inboards up to 1000cc  
                   for all classes in S.P.T. up to 550 cc  
                   for F-4S,

20 to 30 km for racing outboards 850 cc to ∞,

20 to 25 km for all other classes.

With interval of at least one hour between finish of one heat and the start of the following one.

## **108.05 - REPAIRS AND MEASURING**

Repairs are permitted. The substitution of parts (except crankcase) is permitted but must be done under supervision of a technical officer. In those classes where the engine(s) or motor(s) are restricted, such substitution is only to be effected with original parts. Should it be necessary to effect the repairs outside the controlled area, this must be done under supervision of a technical officer.

In multi-heat races a complete engine change is possible: then if it is before time trials no penalty. If after time trials, start low end of jetty. If after first heat or more, all points gained are removed. Start next heat with zero points.

After the race, the first classified boat and engine must be measured by the Technical Officer. A sufficient number of boats must stay in the "parc fermé" until the winner is established.

## **108.06 - RESULTS**

***A driver's three best heats of the four are to be considered for the results.***

When through force majeure (bad weather etc.) the heats are reduced in number or length the final positions are a valid race result.

All classes must race separately even if they belong to the same series.

The races for the Championships are not to be combined with races for other cups or trophies bearing another name.

The organising club will present a gold - silver - bronze medal to the top three drivers, unless U.I.M. distributes the medals (to World Championships and to Formula European Championships).

Other prizes may be awarded.

A driver who has entered for a Continental Championship cannot be compelled to enter other races programmed during the meeting.

As soon as the results have been verified, the National Authority forwards these results to the U.I.M. Secretariat. ***Up to ten photos of the race may be included.***

The results must be printed or typed. The results must include position, name of driver, country, time/laps and points. Additional information such as sponsor, boat may be mentioned.

If a low emission certified engine is raced, the engine manufacturer, complete with engine model number must be mentioned in the full results and on the commissioner's report.

## **111 - RESERVE NUMBER**

## **112 - RULES FOR DRAG RACES**

### **112.01 - DEFINITIONS**

The word "DRAG RACING", defines a particular kind of racing which originated in the United States and is derived from the slang of American mechanics.

First practised in motor racing, drag racing has now been adopted by motorboat racing enthusiasts.

World records of the different U.I.M. series and classes as well as those of the American Power Boat Association, drag records included, can be homologated by the U.I.M.

The racing regulations of the U.I.M. apply for any point not mentioned in the rules issued annually in the American Power Boat Association Year Book (part. 1 Racing Rules) Year Book, volume 1, Racing Rules).

## **120 - RACING LICENCES**

### **120.01 - COMPULSORY LICENCE**

No one can take part in a U.I.M. race, establish or improve on a U.I.M. record in international class boats, without being in possession of an international licence from his National Authority.

In order to obtain an International licence or Super Licence, following disclaimer must be signed by the licence holder:

“The undersigned... Licensed pilot (licence n ), participating to U.I.M. sanctioned events, yields the media rights of any coverage by the promoter taken during the event, to the U.I.M. for further use by press, radio or television. The right however remains the property of the undersigned”.

### **120.02 - REGISTRATION**

The National Authority establishes each year a list of people to whom licences have been delivered and this is sent to the U.I.M. Secretariat.

The list must include: the name and surname, the address **and e.mail**, the class(es) for International Licence **only**.

These lists may be sent to other National Authorities.

Licence numbers are given annually by the National Authority to the owners and drivers entered on the list.

Any person wishing to obtain a licence must apply to the National Authority through his club.

The licence is granted by the National Authority and is marked “International” as decided by the National Authority. Licence holders must have a U.I.M. rule book. For international endurance races, titled or not titled, only one example of the U.I.M. rules will be required, one per boat and not per **driver**.

Any National Authority has the right to deliver licences to:



- its nationals
- nationals of another country affiliated to the U.I.M. only with the written agreement of the National Authority of that nation.

With the approval of the U.I.M. a National Authority may also deliver licences to persons belonging to a country which is not yet affiliated to the U.I.M.

Drivers are only permitted to hold licences from one National Authority.

A National Authority may refuse to give a licence. Notification of this is sent to all affiliated clubs and to the U.I.M.

### **120.03 - VALIDITY OF LICENCES**

Licences are valid from the 1<sup>st</sup> of January until the 31<sup>st</sup> of December each year, unless local circumstances require other dates, but validity should always be shown on the licence itself, and must be for one year.

A licence is valid in any country affiliated to the Union and entitles the holder to enter or drive in his boat in all competitions organised in any affiliated country, provided he complies with what is stated in the U.I.M. general racing rules.

However, for any event held under special rules, the licence holder must abide by the rules in question.

### **120.04 - COST OF LICENCE**

The cost of the yearly licence is to be fixed by the National Authority.

### **120.05 - EXAMINATION OF LICENCES**

At any meeting, the holder must produce his licence at the request of any official of the meeting.

## **120.06 - CANCELLATION OF LICENCE**

Anybody who takes part in an unauthorised meeting loses his licence.

However, if the unauthorised meeting is held in waters of a country other than the one which has delivered the licence, both National Authorities must agree as to the duration of the suspension. The U.I.M. decides finally in case of dispute.

## **120.07 - PSEUDONYM**

The use of a pseudonym must be requested to the National Authority and the National Authority marks the pseudonym on the licence.

A licence holder, as long as he is listed under a pseudonym, may not take part in any sports event under any other name.

Changing a pseudonym is subject to the same formalities as the adoption of it. Anyone who has chosen a pseudonym may not return to his actual name until the National Authority has agreed and has delivered a new licence.

The driver may only race under his name or the pseudonym written on the licence.

## **120.08 - SUPER-LICENCE ENDORSEMENT FOR WORLD FORMULA SERIES RACING**

**120.08.01** Before being granted a superlicence, drivers must have taken part in 10 circuit races for class S catamarans equipped with an engine of a capacity higher than 750 cc, or in three races for class O boat with an engine of a capacity 500 cc or higher. Updates rules see blue pages.

**120.08.02** In F125, F250, F350, F500, F1000, FR1000, Formula OSY and F4, there is no superlicence but National Authorities will have to send to U.I.M. before the end of February the list of drivers racing in these categories and formulas, with their addresses.

**120.08.03** The Secretariat of U.I.M. will hold all the information referred to in 120.08.02 as soon as it is received.

## **200 - RACE ORGANISATION**

### **200.01 - GENERAL**

The following bodies have the right to organise any motor-boating event: National Authorities; Affiliated Clubs; Corresponding members of the U.I.M. contracted promoters (with the agreement of the National Authority).

All events have to be sanctioned by the National Authority.

Affiliation to the National Authority implies their acceptance of the national rules and those of the U.I.M.

A club, member or driver who is suspended, is not allowed to take part in any sporting event in his country or in any other country neither as a driver nor as an official, as long as the suspension lasts.

A member or a driver who takes part in any race in a foreign country affiliated to the U.I.M. is ipso facto under the jurisdiction of the National Authority of that country.

A member or a driver belonging to a country which is not affiliated, is to be considered as a national of the country where he takes part in a race.

All clubs, race organisers, officials and drivers are obliged to know the general rules of the U.I.M. as well as the rules related to races or series (local, national or international). Two copies of the present U.I.M. rulebook and up to date amendments must be available at every race.

All races organised by the National Authorities or their clubs are subject to the U.I.M. racing rules. All rules and programmes must mention this.

The general racing rules and the rules related to records are applicable to all the international series.

## **200.02 - INTERPRETATION OF THE RULES**

In case of conflicting rules, those rules concerning series and classes are to prevail over the general rules.

In all cases not foreseen by the International rules or seemingly inaccurately defined, the National Authority, a race committee, race jury or an appeal board, is to judge bearing in mind the intention of the disputed rule.

## **201 - ORGANISING BODIES**

### **201.01 - RACE COMMITTEE**

All races are under control of the organising club who is to nominate:

- An Organising Committee which organises the general and administrative aspects of the meeting;
- A Race Committee which organises and supervises the actual racing and decides whether competitors are eligible or not.

The Race Committee is composed as follows: the Officer of the Day, the Deputy Officer of the day, the Medical Officer, the Race Secretary, the Technical Officers.

The decisions of the Race Committee and the Jury must be based upon the U.I.M. rules, but as no rules can be devised capable of covering every case, the race committee **and the Jury must** discourage all attempts to win by means other than fair racing, superior speed and skill.

The organising committee appoints a Committee that verifies all the documents required i.e. Measurement Certificates, Driving Licence, etc. This Committee also verifies whether or not the boats and motors conform to the rules.

No officer, nor member of the Jury, nor member of a National or International Committee or Commission, is allowed to intervene in the

judgement of a problem in which he is involved himself or is an interested party.

The following are the Race Officials:

1. The Officer of the Day;
2. The Deputy Officer of the day;
3. The Medical Officer;
4. The Secretary of the Race Committee;
5. The Technical Officers;
6. The Course and Buoy Officers;
7. The Timekeepers;
8. The Lap Scorers.

## **201.02 - INTERNATIONAL OFFICERS LISTS**

Lists of International Officers of the days and of International Jury Chairman are deposited in the Secretariat of the U.I.M.

Every year, each National Authority has to transmit the Secretariat its new list of O.O.D. and I.J.C. or the confirmation of the previous year's one not later than September 30<sup>th</sup>.

Each National Authority may propose for enrolment in the list of O.O.D. and I.J.C. only those race Officers that have been regularly qualified by said National Authority.

Requirements for the enrolment of a candidate:

- a) a personal record (containing personal data, address, telephone, fax, numbers and/or e-mail)
- b) knowledge of French or English
- c) not less than a five year experience in the position applied for

Only people enrolled in the U.I.M. lists are allowed to be appointed to the charges mentioned above and therefore to be appointed by their National

Authority to perform such duties in international races valid for U.I.M. titles.

### **201.03 - THE OFFICER OF THE DAY (O.O.D.)**

The Officer of the Day must supervise the organisation of the races on behalf of the Organising Club. He must maintain order on the course, ascertain that all services work properly, ensure that all correspond to the rules and observe the Racing Rules according to the Programme, gather written reports of the Officers and Timekeepers and any other documents that will enable the results to be compiled.

### **201.04 - THE DEPUTY OFFICER OF THE DAY**

The Deputy Officer of the day co-ordinates (together with the Officer of the day) the safety services on shore (fire) as well as on the water (boats, people on board, material). When necessary he stands in for the Officer of the day.

#### **201.04.01 - THE MEDICAL OFFICER**

The Medical Officer is responsible for the medical organisation in the racing area, on shore as well as on the water.

In agreement with the Officer of the day and his deputy, he controls the order of the means of emergency such as life-boats, ambulances, mobile reanimation unit, an eventual airborne ambulance and the first aid station.

In case of intervention on the water, he will take command of the rescue operation following stopping of the race by the Officer of the day.

### **201.05 - THE RACE SECRETARY**

The Race Secretary is responsible on behalf of the O.O.D. for the practical side of the meeting and organisation and must satisfy himself that the various officials know their respective duties and that they have

all the necessary documents and equipment. He must collect all documents.

## **201.06 - DUTIES OF THE RACE OFFICIALS**

The Race Officials shall perform only the duties with which they are entrusted.

## **201.07 - THE TECHNICAL OFFICERS**

The Technical Officers are to make sure that all drivers have their Measurement Certificates and shall verify that the hull and engine conform to the certificate and rules, and make sure that the drivers carry the homologation sheets of the engines or hulls used.

They check and control safety devices for boats and drivers as provided for in the rules.

Special attention must be paid to the automatic engine shut-off and that the racing number conform with the rules.

They verify the synchronisation of the clock and the camera if used.

After the race, they must do all necessary checks, all infringement must be communicated in writing to the O.O.D.

## **201.08 - THE BUOY AND COURSE OFFICERS**

They must ensure that the drivers conform to the racing rules. Any irregularities must immediately be reported to the O.O.D. by radio, and in writing following the event, the O.O.D. will enforce the rules when needed. Buoy and course officials are allowed to be in boats. If they cannot be in boats inside the circuit, there will be two of them: one at the entrance and one at the exit of each turn.

## **201.09 - THE TIMEKEEPERS AND STARTER**

The Timekeepers will:

- calculate on completion the elapsed time of each drivers;
- establish the finishing order after having made all necessary calculations and establish the average speeds;
- for international races there must be at least two timekeepers. Their results must only be handed to the Officer of the Day;
- the starter signals the start when ordered to do so by the Officer of the Day.

## **202 - ADVANCE-PROGRAMME**

### **202.01 - FORWARDING DATE**

45 days before any international race the organising committee must forward at least one advance-programme to the U.I.M. Secretariat, to the National Authorities and to the invited Clubs and drivers. The advance-program will also be forwarded to the commissioners for recommendations. Any such recommendation should be accomplished at least two weeks prior to the event.

Should the 45 days delay not be complied with, the calendar fee will be double.

The above advance-programme must be written in the language of the organising country and in English and must contain the following information:

- 202.020** the name and the address of the organiser;
- 202.021** the series and classes of boats catered for;
- 202.022** the race or races which will be run;
- 202.023** the venue and the date of the race(s);
- 202.024** the course of each race and plan drawn to scale showing all details as per rule 106.02. Start method, flying start or dead engine start, and maximum numbers of boats on the course.



The spectator areas must be shown and minimum distances between spectator areas and the course marked on the plan. Natural or man-made spectator protection such as fences, docks, etc. shall be noted.

The circuit plan and spectator areas shall be positioned to provide for spectators and drivers safety. Spectators and crews shall not be in the water during the running of a race.

- 202.025** The races are held under the U.I.M. rules;
- 202.026** The special conditions which in accordance with the U.I.M. rules may be added or modified;
- 202.027** Time limit and place to which entries must be sent, and whether written, by fax, by email or by hand;
- 202.028** The amount of the entrance fee, except for Continental or World Championships for which there is no fee;
- 202.029** All information regarding the prizes for each race;
- 202.030** An entry form must be included in the advance programme. Where and when racing instructions can be obtained;
- 202.031** Transport facilities and concessions;
- 202.032** Terms and conditions of a mandatory insurance for personal and material damage to third parties, competitors included;
  - The minimum limit of coverages required;
  - The quality of risks to be covered by the insurance;
  - Whether insurances from other National Authorities are authorised and if they are, in which language they must be drawn up;
  - The amount of insurance fees to be paid on the spot (90€ maximum).
  - If the charge to the drivers for the insurance exceeds 90 euros, the U.I.M. will fine the organising National Authority

with twice the amount exceeding 90 euros per driver that they have had to pay the extra insurance.

- U.I.M. will then return only the extra insurance fee to each drivers National Authority.

- 202.033** Minimum age of competitors;
- 202.034** Times for practice per class and the interval between the heats;
- 202.035** Full instructions regarding noise regulations;
- 202.036** Date and times for scrutineering;
- 202.037** Should no publicity be allowed during a race, this is to be mentioned in the advance-programme;
- 202.038** The time limits for late starters and finishers;
- 202.039** No modifications are to be made to any particular rule after the advance-programme is posted except if decided by the Race Committee and for cases of force majeure only. The modifications must be communicated, by written means, to the officials and participants, at least 1 hour before the first start.
- 202.040** Place and time of the drivers meeting.
- 202.041** The protest fee. (maximum 80 euro)
- 202.042** Organisers must announce if they will supply fuel at the meeting, at what price, and to what manufacturing specification and octane rating.
- 202.043** There must not be any financial penalty for not respecting any U.I.M. rules other than what is provided for in the U.I.M. rulebook.
- 202.044** The cost of the buoy (maximum **200 €**).

## **203 - ENTRIES**

### **203.01 - RATIFICATION**

The National Authorities must ratify in writing any entry for drivers wishing to race abroad.

Direct correspondence between the organising committee and foreign drivers is permitted but no entry is to be accepted unless approved by the driver's National Authority.

The Organising Committee will keep blank entry forms at the disposal of the drivers.

An entry is not valid unless it reaches the organising committee within the time prescribed in the advance programme.

### **203.02 - ADMISSION**

No organiser, organising an international race has the right to refuse the entry of a foreign driver duly commissioned by his own National Authority provided said driver conforms to U.I.M. rules.

Drivers need only to supply such particulars as are applicable to the class of their boat.

However, if a driver wishes to enter a boat with a reinforced cockpit (rule 509) in a class where a reinforced cockpit is not mandatory he must mention this in his entry. Acceptance of the entry then binds the organiser to provide the proper rescue facilities as per rule 205.08.

No entry shall be considered accepted until the boat has passed scrutineering and the documents are checked.

Only one boat per driver is allowed to be entered for any championship meeting. Spare hulls and engines are allowed but may only be used as foreseen in the rules.

### **203.03 - ENTRY FEE**

Each organising committee fixes the amount of entry fee for the races. Entry is valid only after payment of the entry fee.

The National Authorities have the right to establish a rule whereby higher fees are imposed on late entries.

### **203.04 - MINIMUM AGE**

Each National Authority has the right to fix a minimum age for the drivers allowed to race on its waters. Such age restriction is to be shown in the advance programme.

#### **203.041 - MINIMUM AGE INTERNATIONAL**

The minimum age for all drivers racing international races is 16 years. For racing in the classes S-P-T up to 400cc, GT30 and the F-4S the minimum age is 14 years (by the race date).

Drivers allowed to race in the class JT250 and GT15 must be 10 years of age (by the race date) and may complete the race season in which they reach 16 years of age.

Minimum age of drivers allowed to race in class Formula Future is listed under 500.10 pt 1.1.

### **203.05 - NATIONALITY**

**Only** the nationality shown on the drivers' licences must be taken into consideration in the classification **and for any flags affixed to the boat.**

#### **203.051 - PUBLICITY ON THE BOATS**

Advertisements may be freely applied on the entire surface of the boat, but there must be a free distance of space of no less than 0,15 meter around the boat number.

No crew can be compelled to carry any advertising whatsoever on their person, clothes or upon the boat that is being raced and his-their refusal to do so cannot in any way be an obstacle to their participation in any race.

Penalties may be applied to any driver who, in the course of any sporting event, has made any advertisement contrary to the truth or distorting the facts.

Political publicity or immoral advertisements are not allowed.

Should no publicity be admitted for an event, this has to be announced in the advance programme.

Any National Authority has the right to fix its own rules regarding publicity for its own boats and courses.

## **204 - RACE INSTRUCTIONS**

### **204.01**

The Organising Committee must clearly state the following points in their race instructions:

**204.011** Places and dates of the race;

**204.012** Layout of course drawn to scale:

- Length of the course;
- Direction of the course;
- Starting line and its marks;
- Finishing line and its marks;
- Full details of buoys;
- Full details of obstacles;
- Prohibited area;

- 204.013** Starting time of each race;  
Signals for each race;
- 204.014** Full particulars of prizes for each race;
- 204.015** Time limit and place for handing over the protests;
- 204.016** Time and place of the distribution of prizes;
- 204.017** Composition of the Race Committee, of the Jury and of the Technical Commission;
- 204.018** List of boats entered for each race and if possible, names and clubs of the drivers;
- 204.019** Place and time at which written instructions will be issued. Where and when the official time is to be communicated and place and time of driver's meeting;
- 204.020** Only drivers whose entries have been accepted by the organising committee have their names printed in the programme.

## **204.02 - ORGANISING COMMITTEE MEETING**

On the day prior to the first race/practise day, a meeting shall be held between the U.I.M. Commissioner and the race organisers/officials, and the promoter (if any), to review all aspects of the race organisation. Time for the meeting will be at 18.00, unless not otherwise agreed.

## **204.03 - DRIVERS MEETING**

A driver's meeting must be held before any training.

It is mandatory for all drivers to attend all driver's meetings.

If these meetings are not held in English, a full and immediate translation into English must be made by an interpreter.

It is mandatory to inform the Drivers of all environmental matters at the Drivers meeting (See Group 700).

## **205 - SAFETY RULES**

### **205.01 - ANNUAL MEDICAL EXAMINATION**

Each National Authority must submit all the drivers under its jurisdiction to an annual medical examination.

Each National Authority must adopt a form to be used for the medical examination.

Each National Authority must submit to a special medical examination any handicapped driver, any driver who has had a serious accident or any driver who, during two or three races, has shown odd behaviour when driving his boat: this check is compulsory before participation in any international race and must be certified by a commission set up by the National Authority of the interested driver; the commission will be composed of a well known specialist, a technician and a delegate of the National Authority; the Commission may give or refuse authorisation as to the eligibility of the driver.

Each National Authority which organises an international race must abide by the regulations approved by the Medical Commission regarding the medical organisation of international races.

### **205.02 - MEDICAL EXAMINATION AT EVENT**

The medical officer who is to be present at any motorboating event has the right to submit any participating driver to psycho-physical examination and this at any time during the event, an alcohol or drug test may be performed.

The result of such examination is immediately communicated to the Race Committee who basing themselves on the report of the medical officer, may suspend the driver from the competition.

Following any accident, the driver must undergo a physical examination and be passed fit by the event medical staff before being permitted to continue in that racing event.

Following any accident, damaged boats must be completely rechecked and approved by the official scrutineer and the U.I.M. Commissioner, before being permitted to rejoin the event.

## **205.02.01 - MEDICAL EXAMINATION - ADDITIONAL REQUIREMENTS**

In order to qualify for a superlicence or for drivers in classes where the U.I.M. world speed record exceeds 210 kmh, 131.25 mph (at 1<sup>st</sup> January of the relevant year), additional items in the medical examination are mandatory.

## **205.02.02 - DOPING TEST CONSUMPTION OF ALCOHOL**

- Competitors shall not be under the influence of alcohol while competing and practising.
- Testing when carried out shall be by using an alcoholmeter.
- A competitor shall, if requested by an authorised official, submit to an alcohol test. Written notification of selection for testing will be handed to a competitor by an authorised official. Refusal or failure to do so may be taken as if a positive test had been ordered and dealt with accordingly.
- a. For international races, any competitor found to have more than **BAC 0,10 0/00 (0,10 g/L blood // AAC 0,075 \*\* mg/L air)** 1 hour before and during testing or race shall be immediately suspended and disqualified from the whole event. A formal report shall be forwarded to the NA of the competitor.

***\*\* value on the equivalent breathalyzer number to be confirmed since no adequate information available at the time of proposal publication.***



If in an organising country, the legal requirements of the above numbers are lower, then these numbers have to be announced in the advance regulations and prevail.

### **205.02.03 - ANTI-DOPING REGULATIONS**

Anti-doping regulations based upon the world anti-doping code.

See separate section in this rulebook.

### **205.03 - MEDICAL EVALUATION SHEET**

Location of test \_\_\_\_\_ Date \_\_\_\_\_

Name \_\_\_\_\_ Surname \_\_\_\_\_

Born in \_\_\_\_\_ Date \_\_\_\_\_

Address \_\_\_\_\_

Status \_\_\_\_\_ Profession \_\_\_\_\_

Date of first involvement in the sport \_\_\_\_\_

Other sports practised \_\_\_\_\_

#### **PRESENT STATE OF HEALTH AND FORMER DISEASES**

Disease (former or current) \_\_\_\_\_

With special mention of \_\_\_\_\_

o Cardiopathy o Coronary o Diabetes Type 1 / 2 (circle the type)

o Epilepsy o High blood pressure

Operations undergone previously \_\_\_\_\_

Dates of these operations \_\_\_\_\_

Accidents (when, where, under which circumstances) \_\_\_\_\_

\_\_\_\_\_  
\_\_\_\_\_

Alcohol \_\_\_\_\_ Tobacco \_\_\_\_\_

Allergies \_\_\_\_\_

Medicines usually/frequently taken \_\_\_\_\_

**205.04 - GENERAL OBJECTIVE EXAMINATION**

Height \_\_\_\_\_ Weight \_\_\_\_\_

Body Mass Index (Weight (kg)/Height<sup>2</sup>(m): \_\_\_\_\_

Any driver with a BMI over 30 kg/m<sup>2</sup> in 2010 must submit in 2010 with his 2010 superlicence application, all detailed examination results required in this form. This will then be submitted to a doctor appointed by the U.I.M. Drivers have until the medical test in 2011 to reduce their BMI to less than 30 kg/m<sup>2</sup>. The 2010 year is a transition period and no one with a BMI over 30 kg/m<sup>2</sup> will be issued a superlicence in 2011.

Age \_\_\_\_\_ Sex \_\_\_\_\_

Congenital or acquired deformities \_\_\_\_\_

Respiratory system \_\_\_\_\_

Spirometry (mandatory) \_\_\_\_\_

FVC (measured/predicted) \_\_\_\_\_

FEV<sub>1</sub> (measured/predicted) \_\_\_\_\_

Cardiovascular system : is there any evidence of abnormality of the heart or cardiovascular system ? o Yes o No

If "Yes", give details below.

\_\_\_\_\_  
 \_\_\_\_\_

Blood pressure at rest \_\_\_\_\_

Heart frequency at rest \_\_\_\_\_

Electrocardiogram at rest \_\_\_\_\_

Stress ECG and blood pressure profile (*see 205.04.1 -additional Items*)

\_\_\_\_\_

Sight-testing (see 205.04.1 - additional items)

Date of the last ophthalmologic check-up (performed by a

Professional ophthalmologist : . . / . . / . . . .

Faculty of vision (uncorrected) R \_\_\_\_\_ L \_\_\_\_\_

(with correction) R \_\_\_\_\_ L \_\_\_\_\_

Vision with both eyes open (wearing corrective lenses if necessary

Field of vision \_\_\_\_\_

Vision of colours: is the applicant's colour vision normal?

Yes  No

If "No", give details below.

Hearing testing \_\_\_\_\_

Urine: Albumine \_\_\_\_\_ Sugar \_\_\_\_\_

Is the Urine analysis normal?  Yes  No

If "No", give details below.

Nervous system \_\_\_\_\_

Others \_\_\_\_\_

Does the applicant have any physical abnormality or restriction of movements in the arms or legs?  Yes  No

If "Yes", give details below.

Is there any evidence of a physical or mental condition (past or present) which could, in your opinion, prevent the applicant from holding a competition licence for motorsport ?

Yes  No

If "Yes", give details below.

---

---

To the Doctor and the Driver :

Are you the applicant's usual doctor? o Yes o No

Your practice stamp (together with your name and qualifications):

Name in capital letters \_\_\_\_\_

Degree \_\_\_\_\_

Address \_\_\_\_\_

\_\_\_\_\_

Tel \_\_\_\_\_

Fax \_\_\_\_\_

Aptitude assessment \_\_\_\_\_

Date \_\_\_\_\_

This is to certify that I have examined the applicant in line with this form.

Signature of the Doctor \_\_\_\_\_

Signature of the Driver \_\_\_\_\_

## **205.04.1 - ADDITIONAL ITEMS FOR SUPER-LICENCE**

Stress ECG and blood pressure profile : electrocardiogram has to be performed under stress on a cycloergometer starting at 60 watts and increasing by 30 watts every two minutes. The driver must be capable of reaching a minimum power level of 2.5 watts (males) - 2.2 watts (females) per kilogram of body weight.

***Treadmill tests are no longer accepted.***

***A written report from the physician (English language) should be enclosed.***

Exhaustive ophthalmological check-up, tested and certified (English language) by a professional ophthalmologist to be renewed every five years and after skull trauma.

## **205.05 - IMMERSION TEST**

Competitors taking part in a race and using a reinforced cockpit as defined in rule 509, must have a certificate of underwater training. This is given by a National Authority and includes an immersion test in a simulated reinforced cockpit. All tests must include demonstrating the drivers ability to use the air supply successfully under water in simulated accident conditions. The immersion test is only valid for 14 months.

A model for the certificate and instructions of how to perform an immersion test are available at the U.I.M. Secretariat.

## **205.06 - LIFE JACKET**

Each person aboard a race boat must wear an efficient life jacket during the race and practice conforming with the following rules:

The efficiency of a life jacket is the sole responsibility of the wearer who must be assured that it conforms with the U.I.M. rules and carries indelible confirmation of this;

Race organisers are required to repeat this important clause in race instructions and in the advance-programme;

This compulsory regulation is for all international races and recommended for national ones. In any case, life jackets must be in conformity with following rule;

Buoyancy: a life jacket must have a minimum of 7,5 kg solid buoyancy for a person weighing up to 60 kg and 9 kg solid buoyancy for those over 60 kg (closed cells foam only);

The disposition of the solid buoyancy must be such as to ensure that an unconscious person shall float face up in the water;

All adjustable straps must be at least 40 mm wide and have a minimum breaking strain of 1000 kg. The crutch straps must be attached at the front at the position of iliac crest and at the back in the sacral region. A recovering attachment must be placed either on the shoulders, or as a chest strap and made with strap of the same quality as indicated above;

Manufactured from fire resistant material and coloured orange;

The back must include a protective plate;

Alternatively, the protective plate on the back may be a separate plate.

The compulsory collar must have rounded edges and extend above the bottom of the helmet. It must not exceed 180 degrees;

A racing life jacket manufacturer must undertake to comply with the rules and print indelibly on the life jacket the following : “conforms with the regulation for a person weighing a maximum of 60 kg” or “for a person weighing over 60 kg”, in respect of the buoyancy.

Flotation overalls are a permitted alternative to life jackets, but must conform to all life jacket requirements (colour, buoyancy, protective plates, collar, etc.). The overalls must also include the cut resistant material required in rule 205.11.

## **205.07 - PROTECTING HELMET**

Any person aboard any boat taking part in races must wear an adequate helmet which at least the upper 50 % (area) must be of fluorescent orange, red, yellow or international orange color. These helmet colors must be bright enough to be clearly visible in the water.

The wearer is entirely responsible for the efficiency of his helmet. The organisers are requested to repeat this important rule in their particular rules, as well as in their advance-programmes, race instructions and programmes.

Each National Authority may request that their nationals wear a helmet of a type laid down in their own national rules.

## **205.08 - SAFETY BOATS**

- 1) The crew of a safety boat should be as follows: one driver, two divers, one doctor or a paramedic who has to be on board at least one boat
- 2) The safety-boat must be in contact by radio with the Officer of the day or the person designated by him
- 3) The safety-boat crew will lift the victims of an accident from the water keeping them in a horizontal position as much as possible, using a rigid stretcher
- 4) It is recommended that one person capable of providing basic life support administration be on board the boat
- 5) When competitors use safety harnesses, the divers must know how to deal with these systems.

### **205.08.01 - TOWING BOATS**

There must be at least four boats for towing damaged boats on circuits up to 2 000 metres.

Each of these boats must cover 1/4 of the circuit, the space to be controlled being in any case limited to an area within a 500 meter radius. The towing boat crew will consist of two people. The towing boat must contain the following equipment:

- one signal flag, one fire extinguisher of a high capacity homologated for fuel fire, ropes and a boat hook.

Towing boats can only come into action once the race has been completed or stopped.

## **205.08.02 - FIRST AID STATION**

A first aid station with qualified medical must be located within the racing area.

At least one ambulance and one mobile resuscitation unit with a qualified doctor must be located within the racing area.

## **205.09 - INSURANCE**

All drivers must be properly insured, either by themselves, with the policy to be produced before the start, or by an insurance covered by the National Authority, the fee being paid by the driver.

If insurance can or must be bought at the race meeting the total cost must be stated in the advance-programme. The cost to the driver must not exceed 90 €.

Do not underestimate your responsibility in accidents occurring during official trials before the verification of the boats and the various documents required. Only verification will make it possible for you to be sure that the driver is insured properly.

## **205.10 - TECHNICAL PROTECTION**

It is forbidden to start the motor with the propeller rotating in the air, except when the boat is launched immediately.

After launching of a boat whose cylinder capacity is more than 750cc, it is forbidden to start the motor or the engine with the afterpart of the boat lifted up and the screw rotating. If it is necessary in order to start a boat of less than 750cc to lift it up, a contrivance must be set up to protect the person(s) who must launch the boat.

This device must leave a free space between the propeller and the above mentioned people.



## 205.11 - CLOTHING PROTECTION

It is mandatory that cut resistant clothing “with equivalent properties to” Kevlar 29 fabric be worn by participants in all boats without reinforced cockpits. All limbs of drivers in both reinforced and non-reinforced cockpits must be covered. A one-piece overall suit must be worn in reinforced cockpits.

## 205.12 - LIFTING OF RACEBOATS

Boats intended to be craned in and out of the water, must have slings and hooks certified to lift minimum the double of the minimum boat weight.

The certification must be located on the slings and the hooks.

All hooks used for lifting raceboats must be a closed hook type.

Lifting eyes on the raceboat must be bolted through the construction of the boat, with minimum 8mm bolts and washers of at least 10 square centimeters area per lifting point.

No boat shall be lifted over people. Lifting a boat with a person on board other than for weighing will disqualify that boat and it's driver.

No boat can be lifted higher than 0.5 m from the boat's trailer or the ground/water with any person on board, while weighing.

## 205.13 - TESTING

Testing outside the race circuit and before or after the authorised hours is prohibited during the event.

## 205.14 - ACCIDENT REVIEW BOARD

At the request of the U.I.M. Commissioner at an event ***or after a fatality, an Accident Review Board set up by Cominsafe*** must conduct a review. This review may consist of interviews with pertinent and appropriate parties, examination of the relevant racing equipment, review

of relevant reports, etc. in order to determine as much useful information as possible. A report of the findings will be filed with U.I.M. and may be used as the basis for rule changes.

## **206 - NATIONALITY AND RACE NUMBERS**

### **206.01 - NATIONALITY**

The national flag, painted in a rectangle 25 cm x 40 cm on the deck, the hood, or the vertical part of the sides: this flag must be visible on both sides of the hull. The national flag should show the nationality of the drivers license.

### **206.02 - NUMBERS**

A race number is allocated to every driver by his National Authority.

Should two drivers of an international competition have the same number:

- 1) the driver of the inviting nation will change his number following the instructions of the Technical officer.
- 2) If none of the drivers is from the organising nation, the driver who entered last will change his number following the instructions of the Technical Officer.

The race number may be fixed:

- 1) on a surface corresponding to the following measures and characteristics: the surface measures 32 x 40 cm and the numbers must be black on a white surface on both sides of the hull in digits of 24 x 14 cm.

***The width of the stroke of the number should be at least 4 cm.***

The space between the rectangular with the digits must be 4 cm.

The white surface must surround the digits with 4 cm.

All numbers must be plain and upright (no italics). No number shall begin with zero, e.g. for 2 digit numbers (sketch as shown below):

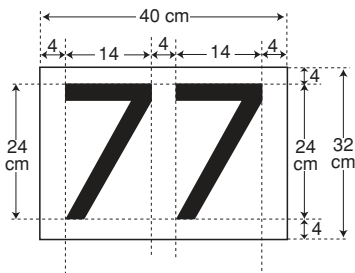

In case of a 3 digit numbers, the length of the surface must be modified consequently.

- 2) the race numbers may also be painted or glued to the slightly curved surfaces and on one vertical surfaces provided that the whole number is within 30 degrees from the vertical position.

It is recommended to use two digits only.

National Flag and the race number must remain visible during the whole race.

### **206.03 - LOSS OF RACE NUMBER**

The absence of the race number or part of that race number leads to the disqualification of that boat from that heat only.

### **206.04 - U.I.M. STICKERS**

The U.I.M. actual logo, minimum 20 cm in length stickers, supplied by the U.I.M. or other manufacturer, must be attached to both sides on a near vertical surface, of all boats participating in U.I.M. titled events. The

loss of the U.I.M. logo will not be a reason for disqualification at post race technical inspection.

## **RULES FOR CIRCUIT RACES 300 - RULES FOR CIRCUIT RACES**

### **300.01 - DEFINITIONS**

<b>French</b>	<b>English</b>	<b>Italian</b>	<b>German</b>
Course	Race	Gara	Rennen
Manche	Heat	Prove	Lauf
Tour	Lap	Giro	Runde
Circuit	Circuit	Circuito	Rundestrecke
Parcours	Dist. covered	Percorso	Rennstrecke
Base	Base	Base	Messtrecke

#### **Circuit**

A circuit is a closed course defined by buoys where races are to be held.

Circuits must be anti-clockwise.

#### **Distance covered:**

Distance covered is the total distance to be covered per heat or race.

#### **Base:**

A base is a course expressly measured for record attempts.

**Marks of the Course:**

Any objects specially indicated as such in the race instructions, are to be considered as marks of the course.

**Obstacle:**

Any non specified object is considered as being an obstacle to free navigation.

**Race:**

A race is a competition in speed between boats held in one or more heats.

**Event:**

An event is one or several races held at the same venue and within one, or more days.

**Laps:**

When calculating percentages of races in any circuit rules: **ONLY** full completed laps (Rounded up) can be counted.

(eg; 75% when full race is 7 laps = 5.20. Rounded up = 6 laps)

**301 - TIMING**

In all international races and championships the timing is carried out by officially appointed timekeepers using certified timing devices graduated to one tenth of a second. The devices must have a split second system one part of which must be capable of being stopped and restarted or any electronic of the same or better accuracy.

## **302 - CIRCUIT**

### **302.1**

All circuits must be measured on site by official surveyors or measured on an official chart of not less than 1/25 000.

At U.I.M. titled races the length of circuits must be for:

O175 / OSY.400 / F-4S - S.T.P. Classes up to 550 cc:

Lap of 1000 metres to 1500 metres with maximum of any one straight 600 metres.

In special circumstances, e.g. for safety reasons the maximum length can be exceeded only for the starting lap.

Classes JT250 / GT15 / GT30 Lap of 800 metres to 1100 metres with maximum straight 400 metres.

All other classes Minimum of 1500 metres, with maximum of 850 metres for any one straight.

The alignment of the start pontoons, or the start line should be such that the pole position has the maximum advantage towards the first turn buoy, compared with the last positions on the starting grid.

If the length of the course cannot be certified, the marks having drifted or for any other reason, the speed is not to be declared in the results (or used in the event of a "dead-heat").

The organisers must ensure that the position of the buoys does not present any danger to the drivers.

It is recommended that the pits be sited where possible away from the race course on the outside.

### **302.2 - RACE CONTROL**

- a) Race control should be situated so that the circuit can be easily seen and controlled;
- b) The race should be observed by three persons:

- the O.O.D.; or his assistant;
  - one or two Commissioners or one or two members of the Jury;
- c) The O.O.D.; is the general observer of the race, being in radio or telephone contact with the assistant, the Deputy Officer Of the Day and the rescue team;
- d) The other two supervisors share the circuit in observation;
- e) The race can only be stopped by order of the O.O.D.;

## **303 - MARKS OF THE COURSE**

### **303.01 - DEFINITIONS**

The Marks of the Course are any objects (boat, buoy...) that are specifically designated as such in the racing instructions. The objects that are not designated specifically as such are to be considered as obstacles.

Course turn buoys must be of a single colour of either orange or yellow 70 x 70 cm (28` x 28`) except the mark on the starting/finishing line buoy which carries a black and white chequered buoy or a white and black striped buoy.

The safety zone (150 m minimum length) is defined by at least one buoy which carries a white and red chequered identification or a white and red striped identification.

The buoys are to be made of rubber or similar material.

An Official is posted near the turning marks. He must observe the turning of the marks and report to the Race Committee.

Should any mark be removed from its proper position either by accident or otherwise, the Officer of the day shall, if possible, have it replaced. Should it be impossible to replace the mark in time for the boats to round it, the Officer of the day shall decide whether the race is to be restarted or not, according to the restart rules.

Protection buoys may be placed on the circuit.

### **303.02 - TURNING BUOYS**

Any turning point of the circuit must be marked with two buoys (minimum).

## **304 - SIGNALS FROM THE SHORE**

### **304.01 - CALL SIGNALS**

When a race, or heat has been started a call signal shall be put up to inform the drivers in the pit area which class is the next to start.

A signal consists of a 35 x 90 cm white board, with the class designation (O500, S850 ...) in black.

The signal should be put in a place where it is easily read from the pit area. If two or more classes start together the call signals for these are to be put up together.

If the time to the next start is so long, that it is not necessary to put the boats into the water immediately, the signal can be supplemented by a sign of similar size and colours showing the estimated starting time.

### **304.02 - FLAG SIGNALS**

The flags used for signalling are the same for all series and must be used in all countries.

The flags used for signalling have the following meaning:

Red: to stop the race and mark serious danger on the circuit;

Yellow: danger on the circuit;

Minimum size of red/yellow flags: 1000 mm x 600 mm



Black: The driver to whom the flag is shown must immediately return to the pits where he will receive instructions from a race official. The flag must be accompanied by the race number of the boat to be stopped.

Chequered, white and black: finish;

Chequered, white and red: course mark showing the safety zone;

Green: This is the signal that all boats are ready to go to start procedure.

### 304.03 - STARTING IN GROUPS

If the number of drivers entered is too large for all of them to start together, the Race committee has to split the group of drivers into several groups.

The Race committee will have each group race a selection race followed by a second chance heat. ***It is mandatory*** that time trials are run to evaluate boats into the two groups instead of random selection.

Drivers of one same nation must be evenly distributed into separate groups.

Example: based on a circuit that can accommodate 20 boats, with 30 entries.

2 groups of boats;

After the selection heats:

the first 8 in each group are selected = 16 boats

A second chance heat grouping the 14 boats that have not been selected:

the first 4 in this heat are selected = 4 boats

Participants in the final heats: 20 boats

The number of laps in the qualifying heats will be reduced and this number, which will be fixed by the organiser, must be mentioned in the advance-programme and recalled at the drivers briefing.

A minimum of one-hour interval is required between the last qualifying heat and the first final heat.

The championship will then take place in four heats, the three best heats for each driver being taken into consideration in the final classification.

If necessary, after all the qualifying races, the organisers reserve the right to make up the number of boats in the final races to the maximum permitted from the repechage heat, when any qualified driver indicates that they cannot participate in the final heats. This cannot be done after the first heat.

## **305 - THE START**

### **305.01**

Starts are:

- flying start with clock (14 boats maximum)
- dead engine start.

### **305.02**

After the starting signal has been given, no boats are allowed on the course other than competitors and official service craft.

### **305.03**

Any boat starting late shall not cross the starting line later than 5 minutes after the starting signal has been given in circuit races (heat races).

Any boat starting late is not allowed to start after the first boat which finishes the race has crossed the finishing line.

Any boat starting late is not allowed to start after the delay provided for in the advance-programme in endurance or long distance races.

## **306 - FLYING START WITH CLOCK, DISCS AND GUN**

The clock must have a dial of no less than 2 meters (6ft. 3/4 ins.) and marked out as follows:



This clock is to be driven electrically or mechanically. It has only one hand moving continuously and indicating the seconds.

The official start is given by the clock. The discs and the gun are supplementary to the clock.

The clock must be run for the majority of the training periods.

### **306.01 - PLACE OF THE CLOCK**

The clock must be placed 3 or 4 metres before the starting line and less than 5 metres above the water level.

### **306.02 - DISCS**

A set of five discs, each having a minimum diameter of 40 cm (15 3/4 ins.) pivots in a white frame. One side of the disc is black and the other white. The discs are numbered 5, 4, 3, 2, 1 on the white side. The figures must be 25 cm high at least and 5 cm thick. These discs are worked by hand. It is recommended, to use discs as large as possible.

Discs must be located in a place which is clearly visible to all the drivers. Sometimes, it is necessary to have two sets of discs (one close to starting line and the other easily visible from the boat park).

### **306.03 - GUN**

Any audible signal loud enough to be heard above the sound of the motors. The gun may be replaced by a rocket pistol.

No other signal than those described above are to be used.

### **306.04 - STARTING LINE**

The starting and finishing line is marked by two poles erected on the shore and surmounted by a triangular mark with one top upwards and one top downwards.

Both poles are erected on the shore at different heights placed in line one behind the other adjacent to the jury.

The distance between the starting line and the first turning buoy must be at least 300 metres (984 feet).

The distance between the shore and the inside safety buoys before the starting line must be at least 50 metres(164 feet).

### **306.05 - SAFETY ZONE**

It is compulsory to determine a zone of 150 metres minimum in length marked by one or two buoys with a red and white chequered or striped

identification at one end, the other end is the starting line marked by one or by two buoys with a black and white chequered or striped identification.

### **306.06 - BEFORE THE START**

During the five minutes preceding the start, boats must not enter in this safety zone, except for the start.

When the warning signal is given 5 minutes before the start, no boats are allowed to be on the water except racing boats and official boats.

The rules of the road (Rule 312) are also applied in that zone. Any infringement will lead to the disqualification for that particular heat or race.

The organisers using this starting system must use a still or movie-camera or a video tape recorder which must be synchronised with the clock.

### **306.07 - THE START**

The start will be given as follows:

- a) 5 minutes before the start, the class letter is hoisted and a gun fired. The five discs are shown with the numbered side towards the course. The hand of the clock is placed on the zero position (12 o'clock).
- b) 4 minutes before the start, the disc number 5 is turned black.
- c) 3 minutes before the start, the disc number 4 is turned black
- d) 2 minutes before the start, the disc number 3 is turned black
- e) 1 minute before the start, the disc number 2 is turned black, the clock is started
- f) At starting time, the disc number 1 is turned black. The clock is stopped and a gun is fired.

The clock, discs, letters and gun and camera / video must be synchronised.

### **306.08 - APPROACHES TO THE STARTING LINE**

Any boat approaching the starting line other than at a right angle within a zone of 150 metres minimum (495 feet) marked by at least one buoy with a red and white chequered or striped identification (which must be left to port), will be disqualified. Boats can not enter in this zone during the five minutes preceding the start, boats must not navigate in the reverse direction of the course and rules of the road apply.

A boat which has not left after the starting signal, can not pass in reverse direction between the starting line.

A mandatory training period will be held to allow drivers an opportunity to familiarise themselves with the safety zone and approach to the starting line prior to actual competition.

### **306.09 - BOAT STARTING BEFORE TIME**

Boats starting before time are disqualified for that race, heat or series.

Boats which cross the starting line in either direction during the five minutes before the start are disqualified and get zero points in that heat.

If the numbers of boats which started before time are all known the race continues and is valid but the boats which started before time are disqualified for that race (or heat).

If the Race Committee cannot note all the numbers of the boat which started before time, it will restart the race. The leading boat across the starting line that starts before time will be disqualified and not allowed to participate in the restart of that race.

## **307 - DEAD ENGINE START FROM A QUAY, A JETTY OR A BEACH**

### **307.01**

All start jetties of the relevant classes should be inclined up to 50 degrees to the line of travel at the start.

Whilst every effort must be made by the organisers to obtain this, a jetty start can still be used even if perpendicular.

Boats should be drawn up stern first, engine dead, to a jetty, floating stage or beach. Boats without electric starts may have external aid from the jetty.

The jetty or floating stage must be long enough for all boats starting plus a length equal to 0.75metres for each boat and with a minimum width of 2.5 metres.

The jetty must be stable even when the maximum permitted boats plus maximum 3 mechanics per boat prior to launch. If not the numbers starting must be reduced and must be reported to the U.I.M. by the Commissioner.

Positions on the jetty are determined by individual qualifying times or from qualifying heats.

Jetty positions for qualifying heats should be taken from available lap times and not by random choice.

Pole position boat does not have the choice of ends. This is announced by the O.O.D. at the drivers meeting [if challenged].

When qualifying heats are run the jetty positions for the actual final heats are allocated by the times from the two heats. The qualifying boats from the “repêchage” heat are positioned at the lower end of the jetty.

Jetty positions, in multi-heat races, after the first heat, are the finishing positions in the prior heat.

## 307.02

The distance between the start line and the first turn mark must be in a straight line and at least 300 meters.

At dead engine starts, drivers must keep their relative jetty positions to the first turning buoy and through completion of that turn, ***not interfering in the path of competing boats***. Sufficient room on the inside must be left by the leading boat, if not pole, to allow others higher on the jetty to negotiate the turn. The inclusion of a ***mandatory starting/alignment*** buoy for safety does not count as the first turning buoy when keeping your lane. ***For the "O" hydroplane classes, the first turn must consist of a minimum of 4 buoys placed to create at least a 35 meter turning radius.***

Breaking this rule will result in one or more of the following penalties, which are disqualification, one lap penalty or a yellow card, depending on the severity.

It is prohibited to stand up during start and while racing.

At all dead engine starts at international titled races, the start may be videotaped (or similar). This is to be done from a position as high as possible and/or from a place in extension of the start lane.

## 307.03

The start will be given as follows:

When the jetty marshal is satisfied that all drivers are ready to start, with engines stopped he will raise a green flag. The O.O.D. or starter will commence the start procedure.

The O.O.D. or starter may decide at any time, if the judges it necessary, to cancel the start by showing the red flag and recommences the starting procedure again.

The two minute board is shown. Alternatively the time can be lengthened to 3 minutes if notified at driver's meeting.

One minute before red light is switched on a "1" minute board is shown.



30 seconds before red light is switched on a “30” board is shown.

Engines must not be run after this signal.

At the end of the 30 seconds the red light is switch on.

After 5-12 seconds the red lights are switched off, this is the signal to start. All information start boards to be shown for their applicable time.

### **307.04**

Those drivers running their engines during the last 30 seconds before the start are disqualified.

Those drivers starting their engines or leaving the jetty whilst the red light is on lose one lap.

Those drivers rotating their engines (with ignition switched off) prior to the red lights going off lose one lap.

After an announced time the red light will be shown again.

Late starters: A driver who has failed to start before the red light is shown again, must wait until the whole field has passed the start jetty and the jetty marshall indicates that he may join the race in the proper way.

Any boat starting unsuccessfully must be returned to shore. Any crew member swimming, or wading, out to a boat will cause his entry to be disqualified.

### **307.05 - MATCH RACE RULES**

Qualifying from time trial position. (numbers on sheet are timed trial qualifying positions).

Qualifying matrix for 16 boats

- First elimination round
- Quarter-finals

- Semi-finals
- Third place race
- Final

#### Qualifying matrix for 8 boats

- First elimination round
- Semi-finals
- Third place race
- Final

#### Course

- Three pin course (by a straight line)
- Round the first turning buoy it should be a sausage buoy (safety zone) to keep the lane for both drivers
- The third buoy is the same for both drivers
- Finish line is the same for both drivers
- Both drivers do one long and one short lap
- The longest lap should not be more than 800 m total

#### Start

- By light
- From a pontoon
- Side by side
- Inside driver go for the shortest lap
- The outside driver goes for the furthest buoy
- With double heat the driver switch lanes

- If a driver does not start the other driver must complete the course

#### Finish single heat

- The driver who passing the finish line first is the winner of this Match Race heat, there may be time keeping, if required for minor places overall position.

#### Finish double heat

- The driver who made the best average time is the winner of the double heat

#### Penalties (disqualification)

- Non-start
- Jump start
- Cutting course
- Impeding other course

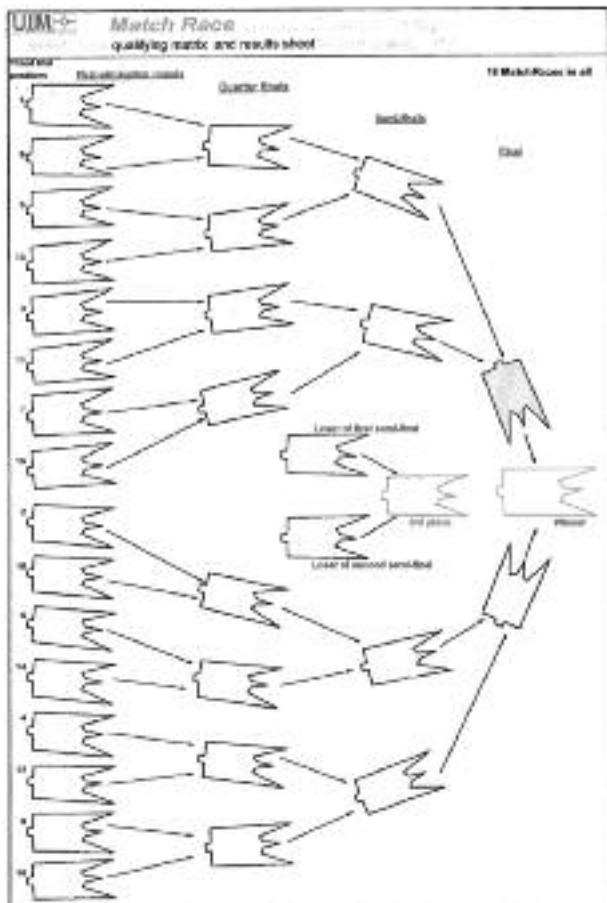

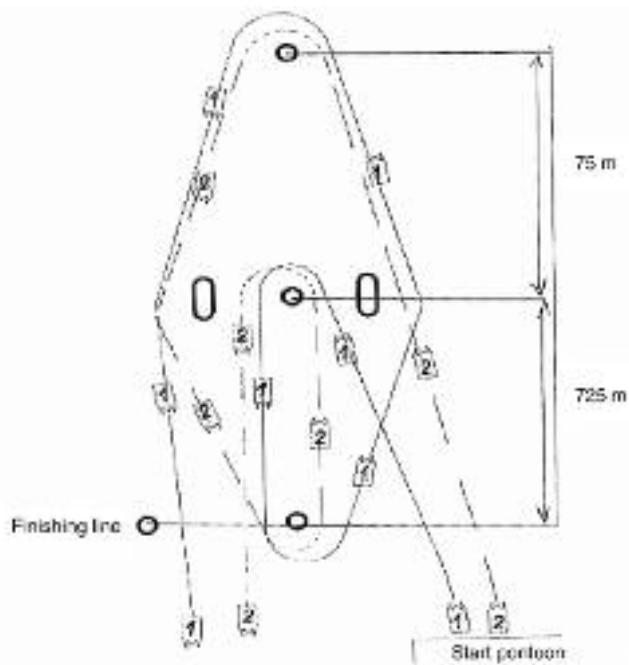

START PONTOON  
ANGLED TO GIVE  
SAME DISTANCE  
FOR BOTH START LINES

## **308 - RACE CANCELLED**

The Race Committee has the power to cancel any race should unfavourable weather or other serious circumstances render such action necessary.

## **309 - RACE POSTPONED**

### **309.01**

The Race Committee has the right to postpone a race, in which case the letter "R" and the class letter are hoisted. Races this postponed are subject to written notice on the notice board.

The Officer of the day may postpone the start, even after the first signals have been given, but only in cases of force majeure or if an error in the starting signals has been made.

### **309.02**

In both cases, signalling is to be recommenced. When the need for postponement has passed, the Race Committee signals the start according to the instructions contained in the programme.

New entries are not to be accepted for postponed races.

Only drivers who duly entered and were present when the race was postponed are admitted.

### **309.03**

A race or heat must in no case be postponed more than 24 hours. If it is impossible to race within this time, the other races or heats held will be used as a basis for classification.

## **310 - RACE SHORTENED**

A shortened race is a race over a course which has been shortened by the Race Committee before the start.

If a race is shortened due to force majeure, it is at the discretion of the O.O.D. (and the U.I.M. Commissioner if present) to alter the time table, and if necessary the course layout accordingly.

If the race is declared to be on rough water, the number of laps should ideally be maintained, but may be reduced if seen fit by the O.O.D. If time permits, the circuit layout can be changed, as agreed by the O.O.D., U.I.M. commissioner and the driver's representative.

If there is a change to the race course after time trials, there may be extra fee practise, if time permits.

The decision with instructions about the shortened course must be handed in writing to the drivers and the timekeepers.

## **311 - RACE STOPPED AND RE-STARTS**

### **311.01 - GENERALLY**

1. A stopped race is a race interrupted by the O.O.D. after the start.
2. The stopping of a race is the sole decision of the O.O.D. and officials specially mandated by the O.O.D. ***The signal to stop will be the display of red flags shown at prominent positions together with mandatory firing of a red flare or buoyant orange/red smoke flares. The display of these flares is optional at U.I.M. non-titled events.*** It is recommended that the start lights are turned toward the general direction of racing after the start and switched on, in a red flag situation as an additional warning.
3. A race is also stopped when anybody is in the water on the course or is considered to be injured, and/or continuation of the race constitutes a danger to those involved.

4. Drivers whose actions result in a stoppage shall not be scored or restart. If the sanctioned driver protests, he shall be permitted to restart, the result being subject to the decision of the jury. So that the racing is not delayed, and protest about the inclusion of a driver after stoppage may, at first, be verbal. A normal written protest must be submitted after the end of the heat or race.
5. Any penalty incurred in any heat is carried forward to any restart of that heat or race.
6. Disqualified drivers shall not restart (unless under protest see 4).
7. Jetty positions are the race positions at the end of the lap prior to the stoppage.
8. Drivers who do not succeed in reaching the jetty with the power of their own engines shall not restart. This rule applies only for classes with electric start.
9. Repairs may only be carried out on boats that have returned to jetty (Rule 8). Repaired boats may rejoin the race as directed by the jetty marshal. Further definition of the repair areas will be given at drivers briefing.
10. In the event of a restart any repaired boat must be ready to take up its correct position on the jetty as directed by the jetty marshal. If the boat is not ready it must start from the bottom end of the jetty. If the race has already restarted the driver can only start under the directions of the jetty marshal.

### **311.02 - RACING IN HEATS**

1. When the leading boat has completed less than 70 % of the required laps the race shall be restarted.
2. There shall be only one restart. In a final heat there shall be a second restart if the first restarted final heat is stopped before 35% of the required laps have been completed.
- 3 Laps gained in previous starts are discarded.



4. The restart shall be for the original number of laps and re-fuelling is permitted. Place for re-fuelling shall be indicated by the organiser.
5. Only the drivers scored at the lap before the stoppage shall be eligible to restart.
6. When a race is stopped after the leading boat has completed at least 70 % of the required laps there is no restart and full points are awarded.
7. Points for a restarted race which is also stopped are:

up to 35 % of the required laps: 50 % POINTS

over 35 % of the required laps: FULL POINTS

Up to 35% means: 'After lead boat has completed at least one full lap and can all be identified by timing control. Failure means zero points.

Points for a second restarted final heat are full points independent of the number of laps in this heat.

### **311.03 - SINGLE HEAT RACING**

1. Eligible drivers may rejoin restarts even if not in previous starts.
2. The race shall be restarted when after having deducted one lap for each stoppage the remaining laps are at least 20 % of the original total.
3. Eligible drivers must return directly to the start, no outside assistance, no refuelling.
4. The number of laps to be scored are those at the end of the lap prior to stoppages.
5. Laps scored from the original start and all restarts shall be aggregated for final positions.

## **312 - RULES OF THE ROAD**

### **312.01**

All racing boats must take any action to avoid a collision at all times.

### **312.02 - OVERLAP**

An overlap is only established when two boats are approximately on the same course and the cockpit of the overtaking boat, if passing on the inside, is even with the cockpit of the overtaken boat.

When overtaking from the outside, an overlap is established when the overtaking boat has passed the overtaken boat sufficiently to alter course without contact.

### **312.03**

The leading boat has right of way until an overlap is established.

### **312.04**

A safe overlap and overtaking manoeuvre is the responsibility of the overtaking boat.

### **312.05**

After an overlap manoeuvre, the overtaken boat must give the overtaking boat room to negotiate turn buoys.

### **312.06**

The overtaking boat cannot force an overlap situation once the lead boat has started his turning manoeuvre.

### **312.07**

An overlap can be attempted from either side of the leading boat.

### **312.08 - OVERTAKING**

An overtaking boat shall keep clear of the boat which is being overtaken.

### **312.11 - PASSING MARKS**

When trying to overtake a boat on the inside, the driver must anticipate the possible direction of the boat he is trying to overtake and must take all necessary action to avoid a collision.

When passing a turn buoy and an overlap has been established, both boats must maintain a safe distance from each other and from the turn buoy.

Overlapping while overtaking does not give priority to the boat overtaking on the inside.

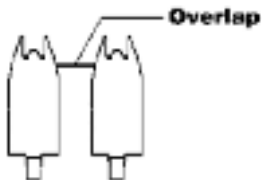

### **312.12 - ALTERING COURSE**

When one of the boats is obliged to keep clear, the other shall not alter her course, to avoid risk of fouling.

A boat must not bear out of her course so as to hinder another in passing to the right.

## **313 - ROUNDING AND FOULING MARKS**

### **313.01**

All marks must be on the left side of the boat unless otherwise stipulated in the advance programme and repeated during the drivers meeting.

On circuits with both left and right hand turns, orange turn buoys must be for left hand turns and yellow buoys must be for right hand turns.

### **313.02**

A boat which rounds a mark in the wrong way loses a lap. For safety reasons, a boat is not allowed to round the mark again after rounding it the wrong way. A boat which rounds a mark again is disqualified.

A boat is considered as having rounded a mark in the wrong way when the buoy official considers that it has passed the mark on the wrong side after starting to negotiate the turn.

### **313.03**

Every turn on the race course must have two turn buoys, minimum.

In the following text first and second buoys refers to the sequence in which they are damaged or destroyed by a boat, not to their position in the turn and the order in which they are to be passed.

In this case, if a driver:

- touches the first turn buoy in a turn: no penalty
- damages or destroys the first buoy: one lap penalty and a fine that will be decided by the Organising Committee and announced in the advance regulations
- touches the second buoy: no penalty

- damages, destroys or dislodges the second buoy: disqualification and a fine that will be decided by the Organising Committee and announced in the advance regulations.
- In the case of a single buoy, penalties will consider that buoy as the second buoy

The penalty lap will be deducted at the end of the heat.

Recommendation: the two buoys should not be tied up together.

Cost of destroying a buoy is maximum **200 euro**.

### **313.04**

A driver who is forced on to a mark by another driver may lodge a protest against that driver.

## **314 - FOULING COMPETING BOATS**

If a boat, in consequence of her neglect of any of these rules fouls another boat, or compels others to foul each other, she is disqualified.

## **315 - MEANS OF PROPULSION**

All methods of propulsion other than motor and paddle are prohibited.

The action of the wind and current will not entail the disqualification on the competitor.

## **316 - YELLOW FLAG SITUATION IN PRACTICE / TIME TRIAL**

In a yellow flag situation in practice / time trial the driver must slow down to a safe speed.

## **317 - FINISHING A RACE**

### **317.01 - THE FINISH**

The finish is shown to a driver by waving a black and white chequered flag.

### **317.02**

A driver who finishes a race or heat must withdraw from the course without hindering the boats that are still in the race.

Drivers have to fulfil at least one extra lap after crossing the finishing line, unless the organiser specifies something else.

A driver who has finished that race and cuts across the course will be disqualified in that race or heat and get zero points.

A boat is timed as completing a race when her stem crosses the finishing line. After finishing the race, the driver must continue to observe any special regulations prescribed by the Race Committee as to keeping clear of the finishing line and the course.

### **317.03**

The Race Committee has the right to stipulate the maximum duration of each race.

Races for the international classes are limited to 4 consecutive days.

For races on the sea, an interval of consecutive 24 hrs might be conceded, if the water conditions justify it.

## **318 - SCORING SYSTEM**

### **318.01**

The boat placed first will be the one having covered the scheduled distance in the shortest time.

All boats will be classified by taking into account the number of complete laps that they have covered and for those, which have completed the same number of laps, after deducting penalties, the order in which they cross the finish line.

Unless otherwise specified, the following scoring system is to be adopted in all races consisting of two or more heats:

1	-	400 pts	11	-	22 pts
2	-	300 pts	12	-	17 pts
3	-	225 pts	13	-	13 pts
4	-	169 pts	14	-	9 pts
5	-	127 pts	15	-	7 pts
6	-	95 pts	16	-	5 pts
7	-	71 pts	17	-	4 pts
8	-	53 pts	18	-	3 pts
9	-	40 pts	19	-	2 pts
10	-	30 pts	20	-	1 pts

### **318.02**

To be awarded points a driver shall have completed at least 75 % of the race winner's distance and cross the finishing line after the leading boat has taken the chequered flag.

Only full completed and recorded laps are taken into account when calculating % (rounded up):

[e.g. Heat of 7 laps. 75% = 5.25 laps. So round up to 6 laps].

For drivers with the same total of laps, ***after deducting any penalties***, their finishing order shall be determined by their positions at the finish of the race.

**For single heat races**

Boats that complete 90%, or more of the race distance, but do not cross the finishing line after the winner has crossed the finishing line, will be classified after those boats that have done the same number of laps and also cross the finishing line after the winner.

For a race stopped, the finishing order is that existing at the end of the lap prior to the stoppage.

Organisers may limit the race to a given time after the winning boat has finished, this must be mentioned in the advance programme.

**318.03**

The official results must be posted on the official notice board within an hour of the end of the races.

**318.04**

A general classification of different classes racing together is not permitted.

**318.05**

National classes may be raced at international meetings.

**318.06**

If boats of different series or classes start together every boat must be classified within its own class.

When the programme for a race meeting does not provide races for all classes, boats not provided for may race in the next higher class in the programme, subject to their acceptance by the Race Committee.



### **318.07**

It is forbidden to take part in a race for a lower class than that to which a boat belongs except with the written consent of all competitors.

The Race Committee may hold a race, as a separate class, for one-design hulls equipped with identical motors.

### **318.08**

If post-race inspection reveals that a boat or motor is illegal, that entry shall be disqualified for each heat in which it raced, and the order of finish shall be corrected for each heat. Final overall race positions shall be obtained by adding the points from the heats after the order of finish has been corrected for each heat.

## **319 - DEAD-HEAT**

### **319.01**

Two boats are in a “dead heat” when :

- They cross the line together,
- They obtain the same points in a multi-heat race.

### **319.02**

In case of a dead heat, the boat having the faster race time , in any heat, will be declared the winner.

Only full completed heats can be used for this purpose.

If the course has been changed considerably between heats,the race time cannot be used.

But if the two relevant race boats race in at least two heats on the same race course (old or new) the faster race time can be applied.

Failing this then revert back to the first full heat and the fastest boat (whatever position) will decide the outcome of a dead heat.

### **319.03**

If the above has been applied, and there is still a “dead heat”, the boat having a higher average speed on any lap in any heat, will be declared the winner.

## **320 - POSTING OF THE RESULTS**

The results of each race must be posted at the pits in a clearly visible position, specified during the driver’s meeting.

## **321 - INSPECTION OF HULLS AND ENGINES**

### **321.01**

Upon completion of a race the engines must remain sealed to prevent any alterations being made.

Refusing to present the engine or the boat entails disqualification.

Any attempt to make changes to the engine or the hull after race and before starting of technical inspection entails disqualification from whole event by the decision of O.O.D. or U.I.M. Commissioner.

### **321.02**

It is compulsory for a driver to make arrangements (tools and special tools and mechanics) so that his motor can be disassembled if the Technical Officers at a post race inspection want to check any part of the motor.

Both driver or/and mechanics shall work as efficiently as possible so that inspection duration can be kept to a minimum.

Engines and boats will be placed pending inspection in a well defined place, which remains under the care of the “ boat park ” official. This is called the “ parc fermé. ”

The boats in each class **must go directly** to the “parc ferme” for **relevant** inspection immediately and directly after the end of the final heat. **Any visit to their respective pits during this move will result in disqualification. Only officials**, driver and maximum two mechanics per boat are allowed to attend.

### **321.03**

After the pre-race technical inspection, the boats must not leave the boat park except for practising or racing.

### **321.04**

If any repairs can only be effected outside the boat park, they must be carried out in the presence of a Technical Officer.

### **321.05**

Officers allowed to attend the inspection:

- The Officer of the Day
- The delegate of National Authority of the driver who's boat/engine is being scrutineered.
- The measurers named by the organising committee
- The driver and a mechanic if necessary
- The U.I.M. Commissioner(s)

The presence of other persons is only allowed if authorised by the Officer of the day.

## **322 - PRIZES**

### **322.01**

Prize giving cannot take place until at least 1 hour after posting of provisional results and NOT BEFORE the technical post race inspection is finished and a protest time against its results has expired.

The Race Jury, in the meantime, must not be dismissed.

It is recommended that immediately after the final race, the provisional first three drivers are paraded in front of the spectators, and introduced to the public and to the media on the official podium.

### **322.02**

A National Authority may ask to reduce the number of prizes according to the number of competitors. However, the value of the prizes must be maintained, as provided for in the advance-programme. This possibility must be explained in the advance-programme.

### **322.03**

In S, T and P series Titled events, the final heat must be completed at least 2 hours before the scheduled time of prize giving to ensure the technical scrutineer has enough time to find the correct winners.

## **323 - REPORTS**

### **323.01**

At the end of the meeting, the Secretary of the Race Committee must send to the Sports Commission of his National Authority a report including:

**323.011** Classification and distribution of prizes:

- 323.012** Report of the timekeepers;
- 323.013** List of drivers;
- 323.014** Penalties;
- 323.015** Documents on any records achieved in conformity with the U.I.M rule-s;
- 323.016** List of protests and decisions relating to these protests;
- 323.017** All necessary documents in order to evaluate the meeting or the race;
- 323.018** These documents must be sent to the Sports Commission of the National Authority within 8 days of the end of the meeting or the race;
- 323.019** After each titled meeting, the organisers must send the results to the Secretariat of the U.I.M.
- 323.020** If the results are taken into consideration for the granting of a trophy or a prize, the points must be sent to the U.I.M. by fax and/or e-mail within 48 hours;
- 323.021** 3 days after a competition, the organising club must send the final result to the National Authorities of all the participants and to the Secretariat of the U.I.M.
- 323.022** Details of technical disqualifications of drivers to be reported to their National Authorities per rule 502.07.

## **400 - JURISDICTION**

### **401.01 - DEFINITIONS**

Jurisdiction applies to:

The U.I.M. Offshore, Circuit, Aquabike and Pleasure Navigation Rules.

### **401.02**

No claim for damages arising from an infringement of any of the U.I.M. rules or the advance notice or any of the race instructions or race bulletins shall be adjudicated upon by any race committee or appeal authority, but shall be subject to the jurisdiction of the courts.

The crew of a racing powerboat which acknowledges infringing a rule does not thereby admit liability for damages.

The findings of fact, and the decision of the protest committee shall be relevant only to the purposes of the powerboat racing rules and shall not be referred to in any proceedings for damage without the written consent of all parties to the protest.

## **402 - JUDICIAL BODIES**

### **402.01 - THE INTERNATIONAL JURY**

The Jury hears any protest raised by a driver.

#### **1. Composition**

The Jury must be composed of at least three members, the Chairman included. The Organisers of the event appoint the Chairman. Each competing country, including the hosting country, may appoint one member delegate who can represent only one country. These appointments must be made in writing, authorised and signed by a National Authority Official and delivered to the event Secretary.

If there are not enough NA appointed members to form a Jury of three persons, the Organisers must appoint additional members, but only enough to reach three persons.

The Jury composition will be announced at the first drivers meeting. The jury must be present at the first drivers meeting.

Race Officials can not be Jury members.

The U.I.M. Commissioner appointed to the event is a full member of the Jury.

In an event comprising races of several classes there may be a different Jury for each class.

## **2. Authority and Duties**

The Jury sits as long as the event lasts, and hears all protests relating to that event.

The jury must decide as soon as possible on all protests presented to it during the event.

### **402.02 - INTERESTED PARTIES**

No member of a Jury who has taken part as a competitor or Official in the race concerning which a judgement is to be given, or knows himself to have directly or indirectly an interest in one of the parties involved, may judge the protest.

However, a member of an International Jury shall not be disqualified even if one of the parties is from his NA.

### **402.03 - THE U.I.M. APPEALS BOARD**

The U.I.M. will decide on Appeals arising from International events according to the provisions laid out in Rule 405.1.

In each case, the U.I.M. Executive Committee, or in case of an appeal lodged against an Executive Committee's decision, the appointed neutral Council member will nominate three members, one to be Chairman after consultation of the relevant commission. The members must not be from the National Authorities of the parties to the case.

One member will act as Clerk to the Board.

## **403 - PROTEST PROCEDURES**

### **403.01 - VALIDITY OF PROTESTS**

Only a driver may protest against facts pertaining only to the races in which he takes part.

Joint protests signed by several drivers will not be considered.

All protests must be in writing - type written or hand written in printed characters in English.

It must state the reason for the protest and be accompanied by any relevant documents that shall provide evidence within the given time and any protest fee as stipulated by the Race Organiser.

All protests must be signed by the protester.

The protest must be handed to the Race Secretariat who must, in the presence of the protester, record the time of receipt.

Any costs involved in verification are to be borne by the losing party.

A written protest can be withdrawn by the protester; he then loses the protest fee.

### **403.02 - PROTEST FEE**

The amount of the Protest fee must be decided by the National Authorities and it must be published in the advance programme. The



maximum amount for a Protest fee will be decided by the U.I.M. General Assembly. It will be 80 €, or an equivalent sum in the national currency.

The Jury must determine whether the protest presented to it, has been lodged according to the rules. If found to be invalid, the reasons must be given to the protester.

If a protest is upheld by the Jury, the fee must be returned to the protester.

### **403.03 - RIGHT OF PROTEST**

A protest can be lodged against the posted provisional results or against any decision made by the Race Committee or against one or several competitors.

In the event of a competitor protesting against a penalty imposed on him by the O.O.D. or the U.I.M. Commissioner and another driver protesting simultaneously against this competitor due to the same incident, the jury will have only one meeting with both competitors being party of this protest procedure.

A protest can only be lodged on a subject which directly concerns the protester himself. A protest which complies with these rules can not be refused by the Jury.

No protest is permitted on jury decisions, they may only be contested by appeal.

### **403.04 - TIME OF LODGING A PROTEST/ PROTEST PERIOD**

A protest regarding the qualification of a boat, a motor, or a driver must be made before the drivers briefing. Starting in a race is considered as acceptance of the conditions and the eligibility of the other competitors. The only exception to the above is when the protester can prove the facts were not given to him before the drivers briefing, then a protest can be lodged up to one hour after the posting of the results.

Any other protest must be lodged within one hour of the first results being posted with the following exceptions:

A protest of a driver (driver "A") against another driver (driver "B") can be lodged within 30 minutes after the posting of the protest form according to rule 404.03 if driver "B" has been penalized and himself protested against this penalty. Without lodging such a protest driver "A" shall not be entitled to appeal against the jury decision.

A protest against new results which are not caused by a jury decision can be lodged within one hour of these new results being posted, but only concerning the decision, which lead to the changing of the results.

A protest against any other decision, posted after the posting of the first results can be lodged within one hour after the posting of this decision.

### **403.05 - JUDGEMENT**

Decisions by the Jury shall be reached by simple majority of votes. In the case of equal votes, the Chairman's vote will be the casting vote.

In the event of a protest, penalties may be agreed, rejected or changed by the jury.

Any judgement pronounced by the Jury stays in effect until altered by the Appeal Board.

### **403.06 - NOTIFICATION OF DECISION**

All decisions by any jury must be notified to the concerned parties in writing, including their right of appeal.

### **403.07 - AVAILABILITY OF DOCUMENTS**

All documents relevant to any decision by the Jury must be filed with the organising N.A. and held available for a higher authority until the time limit for an appeal has expired.

## **404 - HEARING OF THE PROTEST**

### **404.01 - RIGHT TO A HEARING**

Any person being party to a protest, or being charged for an offence against the rules shall have the right to be heard before the Jury in order to defend himself.

The Jury must give notice to all parties of where and when the hearing will take place.

If any party duly notified, fails to appear without giving an acceptable reason, judgement can be rendered by default.

### **404.02 - EVIDENCE**

It is the responsibility of the parties involved in a protest to ensure that witnesses appearing on their behalf together with any other evidence are present and the Chairman of the Race Jury at his/her sole discretion may take their availability into account when determining the time of the hearing.

Any costs incurred by the appearance of witnesses shall be borne by the respective parties unless decided otherwise by the Jury.

### **404.03 - THE HEARING PROCEDURE**

The following procedure must be followed in all hearings unless otherwise stated elsewhere in these rules:

- A copy of the protest must be posted in the same way as the results. The time of posting must be noted on this copy.
- Written minutes must be taken.
- All parties to the case are entitled to be present and to hear and question all evidence at the hearing up to the time the Jury makes its decision. The protest, shall be read out to the parties.

- The parties shall be invited to state their cases. The parties may call witnesses. Each witness, after having given his account of the case, may be questioned by all parties and by the members of the Jury.
- Any member of the Jury who is familiar with the case may give his evidence
- The parties shall be entitled to question each other and any member of the Jury who may have given evidence.
- The witnesses shall withdraw and the parties shall be invited to make a final statement of their cases.
- The Jury may recall any party, previous witness or new witness and call on other evidence to verify the facts.
- The parties must be present during the whole of the recall and must be given the opportunity to question any new evidence after which they may re-make their final statements.

## **405 - THE APPEALS PROCEDURE**

With reference to the 405 appeals procedures, any time limits which end on a Saturday or Sunday shall end on the following Monday. If the Appellant misses any time limit the appeal will be rejected as void.

### **405.01 - APPEAL BOARD**

The members of the Appeal Board may hold other sports functions and consist of a Chairman and two members.

The Appeal Board sits whenever the Chairman calls a meeting.

### **405.02 - INTERESTED PARTIES**

No member of an Appeal Board who has taken part as a competitor or Official in the race concerning which a judgement is to be given, or knows

himself to have directly or indirectly an interest in one of the parties involved, may judge the appeal.

### **405.03 - RIGHT OF APPEAL**

A decision by a Jury may be appealed by the parties involved in the jury meeting when they consider that an injustice has been made against them and/or fresh evidence has been made available that may alter the decision of the Jury.

A driver can also appeal:

- a penalty imposed against him

without the prior lodging of a protest, but only if this was not possible, because the race jury has had dissolved itself before or within the protest period.

### **405.04 - NOTICE OF INTENTION TO APPEAL**

The intention to appeal must be notified in writing to the Secretariat of the U.I.M. by the interested party within four days of the day following the Jury decision or in the case of a decision against which a driver can appeal without the prior lodging of a protest within four days of the day following the notification of this decision to the NA of the driver or if earlier to the driver himself.

### **405.05 - TIME LIMIT**

All appeal documents and fees must be received within ten days from the date when the notice to appeal was received by the U.I.M. Secretariat.

### **405.06 - LODGING OF AN APPEAL**

The appeal must be sent by telefax, letter or E-mail and it must be signed by the appelland. The reasons for the appeal must be stated.

Address, telephone, e-mail and/or fax should be clearly mentioned on the appeal, so that the U.I.M. can send any correspondence directly to the driver with copy to relevant N.A.

### **405.07 - NOTIFICATION OF THE PARTIES OF THE APPEAL**

The U.I.M. Secretariat must within two days from receiving the appeal, notify by telefax or letter the other parties that an appeal has been lodged and that they may send a rejoinder.

Eventual rejoinders must be received within ten days from receiving this notification.

### **405.08 - TIME LIMIT FOR DECISIONS ON APPEALS**

All appeals must be determined no later than forty-five days after the date when the appeal documents and fees were received by the U.I.M. Secretariat.

### **405.09 - APPEAL BOARD DECISIONS**

The Appeal Board takes its own decision based on every information available. The decision of the jury may be upheld, changed or not upheld. The decision of the Appeal Board is final.

### **405.10 - COSTS**

The appeal fee is 1525 €. In addition the driver has to pay 2290 € to the U.I.M. for possible costs of the appeal committee (meetings, telephone, fax, laboratory, experts or other costs of the appeal procedure). The appeal fee for a single championship/ invitation race (not a Formula race, or a WOC race or similar) is 760 €, in addition the driver has to pay 760 €, to the U.I.M. for possible costs of the appeal committee.

If during the procedure further costs arise, the Appellant has to deposit the missing amount accordingly with 14 days from notification.

The driver who appeals has to pay for the meeting costs anyway if the appeal is upheld or not. If the costs of the appeal committee is less than 2290 € then the difference will be paid back to the driver.

The appeal fee of 1525 € will be refunded if the appeal is upheld. If the original decision is changed by the appeal board (405.09), it can decide to refund a percentage of the appeal fee if appropriate. If there is an infringement to rule 405.05, the Chairman of the Appeal Board can decide that the appeal is not considered valid since the expiry dates were not respected. In this case 50 % of the received appeal fee will be reimbursed to the appellant.

The driver may agree to forego an Appeal Committee meeting and for the appeal to be handled through telephone, E-mail and fax, if possible, in order to minimise the cost for the appeal.

## **406 - PENALTIES**

### **406.01 - GENERAL**

Any proven breach of applicable Rules may be penalised.

If the rules do not determine a special penalty for the relevant breach, the penalty to be given has to be proportional to the seriousness of the breach. The proportionality is at the discretion of the decision maker.

The U.I.M. Executive Committee or the relevant National Authority shall only impose penalties, when they deem the relevant infringement to be so serious, that it has to be penalized although the deadlines for penalizing or lodging a protest have already expired. After the expiry of the aforementioned deadlines, a penalty for an ordinary breach of the rules shall in general not be imposed.

The Race Jury or the Appeal Board following a protest or an appeal can (only) impose penalties, which can be imposed by the O.O.D.

## **406.02 - DEADLINES FOR PENALIZING**

The first posted results are provisional for one hour.

The O.O.D. and the U.I.M. Commissioner can only impose Penalties until the expiry of this hour.

The National Authority and/or the U.I.M. Executive Committee can only impose penalties within 3 month from the day, the infringement occurred.

These deadlines are not valid for penalties imposed by the O.O.D. for the reason of post race technical scrutinizing and under the condition that this is stated on the results sheet.

In this case, the results will remain provisional until one hour after the finalization of the post race scrutineering.

The date and time of finalization of the post race scrutineering must be recorded by the U.I.M. Technical Commissioner or other technical scrutinizer in charge.

If the post race scrutineering can not be finalized until the end of the event and the O.O.D. has already left the race site, the penalty has to be imposed as soon as possible after the receipt of the scrutinizing results.

## **406.03 - UNACCEPTABLE BEHAVIOUR**

In order to protect the interests of the sporting community, the following actions may also be penalised by the O.O.D., by the U.I.M. Executive Committee or by the NA of the Licence Holder.

- any deliberate act taken to gain unfair advantage.
- any false act made or statement given with the intention of suppressing facts required for the proper conduct of the race.
- any attempt to bribe or the taking of a bribe.
- any abusive or unsportsmanlike behaviour.



## **406.04 - REPRIMAND**

A Reprimand is a notice of disapproval of an unacceptable action. It must be recorded by the Race Secretariat. A reprimand must be witnessed. A reprimand automatically constitutes warning that if the offence recurs, a heavier penalty will be given. A Reprimand is valid for 12 month.

A reprimand can be given by the O.O.D., or the National Authority of the Licence Holder.

## **406.05 - YELLOW / RED CARDS**

A yellow or red card may be given by the O.O.D. or U.I.M. Commissioner.

A yellow or red card will be confirmed on U.I.M. form which will be posted with the results and if it is confirmed it must be included in the commissioners report. The recipient must be notified privately before a red card is posted.

The driver has one hour from the posting of the penalty to protest (rule 403). If the protest is not upheld he can make an appeal (rule 405).

All yellow/red cards count towards the drivers CV.

Yellow/red cards can only be given for bad behaviour on the water including :

- up to two yellow cards at a time for dangerous driving;
- one red card for extreme blatant dangerous driving.

A driver with a red card is immediately prevented from taking any further part in the event or further heats if a multi-heat race.

A driver with a red card or three yellow cards will also lose the right to take part in the next titled U.I.M. race in his classes/formulae. Then all cards are removed.

All yellow cards will remain valid for the four events in which he competes following the date on which the last yellow card was delivered.

Yellow/red cards must be notified to the U.I.M. and the drivers' National Authority within three days.

The U.I.M. will notify all National Authorities when a driver has one red card or three yellow cards and is therefore suspended from international competition.

### **406.06 - DISQUALIFICATION**

Disqualification deletes a competitor from the results of the heat or race where the offence occurred.

Disqualification is done by the O.O.D.

### **406.07 - TEMPORARY SUSPENSION**

Temporary suspension suspends a competitor, a competitor together with crew, a crew member, or an Official from all or part of an event. Temporary Suspension may be given for serious indiscipline.

Temporary Suspension will be imposed by the O.O.D.

### **406.08 - PROLONGED SUSPENSION**

Prolonged suspension can be imposed on a competitor, an Official or an organisation for deliberate fraud, repeated or very serious indiscipline or very serious misconduct.

Prolonged Suspension can be imposed only by the NA of the licence holder or organisation, or by the U.I.M. Executive Committee.

A Prolonged Suspension is always international. The NA must immediately inform the U.I.M. of a Prolonged Suspension and the U.I.M. must inform all other NA's.

## **406.09 - EXCLUSION**

Exclusion means a permanent loss of all rights to take part in any activities falling under the U.I.M. and its affiliated organisations. A person or an organisation who has committed a moral or sporting offence of extreme gravity is liable to be excluded.

A sentence of exclusion can be pronounced only by the NA of the licence holder or organisation, or by the U.I.M. Executive Committee.

Exclusion is always International. The NA must immediately inform the U.I.M. when it has imposed a sentence of Exclusion and the U.I.M. must inform all other NA's.

In the case of suspension, prolonged suspension or exclusion, all National Authorities and therefore their affiliated clubs bind themselves to respect the decision and apply it in their own country.

## **407 - PRIORITY OF THESE RULES**

The course of the U.I.M. has to be exhausted, before the dispute can be brought before civil court.

## **408 - POWERBOAT PROTEST FORM**

### **PART A**

is for you, the driver, to complete and hand in within the specified time limit.

### **PART B**

Is for you, the driver, to complete and give to the Protest Jury Chairman at the beginning of the Protest Meeting.

## DRIVERS PROTEST FORM

### PART A

#### SECTION 1

NAME OF EVENT:                      DATE OF RACE OR HEAT:

HEAT NUMBER:                      CLASS:

#### SECTION 2

YOUR NAME (PROTESTOR)

YOUR BOAT NUMBER:              BOAT NAME:

#### SECTION 3

I (the Protestor) am protesting against: (tick ✓ as appropriate)

- To seek correction from the Race Organising Committee for actions or omissions.
- Another driver, name:              Boat No:
- The Results as posted

#### SECTION 4

Which rule has been infringed

Time of incident:

On which lap was the incident

Where was the incident

What is the desired result of protest

#### SECTION 5

Your signature

Time of signature



## **409 - ARBITRATION**

### **409.01 - GENERAL**

A party of the appeal procedure has the right to ask for a final arbitration at the CAS (Court of Arbitration for Sport). The commencement of the arbitration procedure requires the acceptance of the mandate by the CAS. In the event that the CAS refuses to accept the mandate for arbitration the decision of the Appeal Board remains final. The CAS procedure must abide by the following rules.

### **409.02 - PARTIES OF THE ARBITRATION PROCEDURE**

- a. The U.I.M. will be party of the arbitration procedure and will be represented by the chairman of the Appeal Board.
- b. Any other party of the appeal procedure shall be notified of the arbitration procedure and may join the arbitration procedure as party by written declaration to the U.I.M. office or directly to the CAS.

### **409.03 - DEADLINES FOR ARBITRATION**

The intention to ask for arbitration must be notified in writing to the secretariat of the U.I.M. by the interested party within 7 days of the day following the notification of the appeal decision.

A written justification for the claim for arbitration must be received by the Secretariat of the U.I.M. within 14 days from the day the intention to ask for arbitration was received by the U.I.M. secretariat.

The notification and the justification must be signed by the party.

### **409.04 - FEE AND COSTS**

The U.I.M. arbitration fee is 1.525,00 EUR. The CAS may decide to refund/ partly refund this fee according to rule 405.10.

Regardless of the final outcome of the arbitration procedure all costs arising out from the arbitration by the CAS (e.g. invoices from the CAS or from experts mandated by or on the initiative of the CAS, travel, accommodation and communication costs of the U.I.M. representative or similar) are borne by the party who asks for arbitration unless differently foreseen below.

This party must deposit an amount that covers all such possible costs no later than 14 days after being notified of the amount. The Secretary General has to determine this amount after consultation with the CAS and taking into consideration an amount of 2.290,00 EUR for possible costs arising to the U.I.M. The deposit has to be paid by bank transfer the U.I.M. or directly to the CAS as determined by the U.I.M. Secretary General. If during the procedure further costs arise, the party who asks for arbitration has to deposit the missing amount accordingly within 14 days from notification.

A party according to rule 409.02. b. bears the costs that arise from the performance of its rights as party of the arbitration procedure including but not limited to travel and accommodation costs, consulting fees and similar.

## **409.05 - FURTHER PROCEDURE**

The CAS will be mandated by the parties involved but only through the U.I.M. secretariat. The U.I.M. will assist the party by drafting and transferring the mandate to the CAS. The U.I.M. must not transfer any mandate to the CAS unless the arbitration documents and fees according to rules 409.03 and 409.04 will be received in due time.

If the interested party misses any deadline, this party loses the procedure and the decision of the Appeal Board will be automatically upheld. The U.I.M. secretariat in this case will not submit the mandate to the CAS or withdraw any mandate that might have been submitted. In this case the interested party has to pay 50% of the arbitration fee and any costs according to rule 409.04.

The further procedure shall be determined by the CAS.

**409.06**

The decision of the CAS will be final and it shall not be subject to any further jurisdiction.



## **500 - INTERNATIONAL SERIES AND CLASSES**

### **500.01 - DEFINITIONS**

The general racing rules and the rules governing records are applicable to all international series.

By boat we understand any vessel used in powerboating (hydroplane, monohull, catamaran etc....).

A boat is a vessel that floats on the water when stationary and continuously derives support, directional control or propulsive effort from hydrodynamic forces.

### **500.02 - INTERNATIONAL SERIES AND CLASSES**

The following example serves to clearly define the words “series” and “class”:

The series of Racing Outboards is divided into twelve capacity classes being: 125cc, 175cc, 250cc, 350cc, 500cc, 700cc, 850cc, 1000cc, 1500cc, 2000cc, 3000cc and  $\infty$  cc.

The request to accept any new international series or class has to be presented by at least three National Authorities.

All series and classes for which the rules have been drawn up by U.I.M. are international.

All national bodies are bound to observe these rules without any alteration whatsoever. Only U.I.M. has the right to change the rules.

### **500.03 - RECOGNISED SERIES AND CLASSES**

All national series and classes for which the rules have been properly established by a National Authority are recognised by U.I.M.

## **500.04 - ENTRY LEVEL RACING CLASSES**

U.I.M. proposes to establish, in each National Authority, Junior classes (as from 12 years of age) in conformity with the national legislation.

U.I.M. will publish the list (unrestrictive) of classes already in operation (i.e. APBA classes, OSY 400, etc.).

U.I.M. reserves the right to propose other classes and to draw up, whenever required in the future, international rules permitting competition between countries.

## **500.10 - RULES - FORMULA FUTURE**

### **1. DRIVERS, CLASSES AND TEAMS**

Drivers are race in 5 classes. Classes are determined by the age of the driver on 31 December of the relevant year. Classes are as follows:

Class 1	ages	8 - 9 years
Class 2	ages	10 - 11 years
Class 3	ages	12 - 13 years
Class 4	ages	14 - 15 years
Class 5	ages	16 - 18 years

Participating in a Formula Future event is at each driver's own risk. As a minor, each participant must have a waiver of liability signed by either parent or other responsible guardian.

Drivers and any possible co-drivers must be able to swim and must wear sports clothes and flat-heeled shoes (with no heels) in order to be allowed to start.

Teams set up by educational institutions, sports clubs and other organisations can take part in the competitions.

Each team includes a maximum of two drivers from each age group. At the Continental or World Championship events, each national authority may be represented by one team only.

Each team shall have an official adult representative, a team manager and must nominate a captain.

The responsibility of a captain is to provide management and guidance as well as to ensure the proper behaviour of his young team mates.

All drivers, official representatives of the teams and all race officials must be familiar with the U.I.M. Formula Future rules.

## **2. BOATS, ENGINES AND EQUIPMENT**

Each team includes a maximum of two drivers from each age group. At the Continental or World Championship events, each national authority may be represented by one team only. Boats, engines, propellers and other equipment required are provided by the organizer and should be of standard commercial production.

Boats must have a maximum length of 3.6m and a width between 1.3m and 1.7m.

When operating the boat, every driver and co-driver shall at all times wear a helmet and a life jacket, provided by the organizer.

All the boats used at the Championship must have an identification number ***and/or different colours.***

Boats in Classes 1 - 3 shall be RIB type boats powered by an outboard engine with a minimum power of 5h.p. (3.7 kW) and a maximum power of 8h.p. (6kW) for two stroke engines and a maximum power of 10 h.p. (7.4kW) for four-stroke engines, with manual engine steering (tiller arm), if possible with automatic reverse.

A co-driver is mandatory for Classes 1 - 3. During a stage each driver in a class should have his 'own' co-driver. If the co-driver has to be replaced (for whatever reason), the person replacing him must have the same weight or must carry ballast near to his/her sitting position to achieve the same weight as the replaced co-driver.

The boats for categories 1- 3 must be equipped with two separate kill-switches, or alternatively with two separate connections to one kill-switch in order to allow the driver and/or the co-driver to stop the engine immediately.

The driver may start only after the kill-switches of driver and co-driver have been properly attached to their bodies or to any part of their equipment (for example life jacket).

Boats in Classes 4 - 5 shall be RIB type boats, powered by an outboard engine with a minimum power of 10h.p. (7.3 kW) and a maximum power of 15h.p. (11.2kW).

The boats must be equipped with a steering wheel, a jockey seat for the driver with the speed lever on the starboard/right side and a kill-switch.

The driver is allowed to start only after his kill-switch has been properly attached to his body or to any part of his equipment (for example life jacket).

### **3. ORGANIZATION**

***World and Continental championships may be run as separate events at the same venue and date.***

#### **3.1 - Advance programme**

The Advance programme must be in accordance with the U.I.M. circuit rules. In addition it must mention at least:

- Accommodation of the teams and representatives (prices, distance to the race venue, food, transport);
- Transport possibilities on arrival and departure - from the airport/highway to the venue, maps etc.;
- The boats and engines used for the event with photos;
- Data required for the insurance provided.

### **3.2 - Accident insurance**

The organizer provides a free accident insurance for all drivers.

### **3.3 - Entries**

Entries of the drivers and teams must be received by the organizer at least 4 weeks before the date of the event. Entries must include complete data of all participating drivers of the teams (name, surname, birth date, address, passport number and sex) -they are required for the accident insurance (mentioned in point 3.2).

### **3.4 - Official language**

The official language for all correspondence, documents and meetings will be English - in compliance with U.I.M. rules.

All technical and public announcements should be done both in English and in the language of the host country.

The O.O.D. must speak and understand English or must have an official interpreter with him/her for the duration of the race meeting.

### **3.5 - Protests**

Protests may be submitted only by the team manager.

Protests concerning any part of the boat, engine or equipment, provided by the organizer, must be submitted not more than 1(one) hour after the finish of the official free practice.

All other protest conditions are in accordance with U.I.M rule 403.

### **3.6 - Jury**

Jury is set up of from delegates officially nominated by the teams (NA, sports club etc.) - one delegate for each team (with a minimum of 3 persons).

All duties, responsibilities and conditions for the jury are as described in U.I.M. rule 402.

### **3.7 - Registration procedure**

Registration procedure must be made as described in the time schedule of the advance programme.

Each driver shall receive a personal number and a registration form.

The personal number shall be in black figures, 20 cm high, on a white square of 25 cm by 25 cm and should be visible at all times during the race.

It is obligatory for the driver to wear his/her personal number during every stage of the race.

When registering, each driver shall be weighed. If the driver has a body weight lower than the statistical average, the organiser will add extra weight (ballast) in order to reach the required average weight (driver +ballast) for each class.

Ballast must be located near the driving position and must be securely attached to the boat.

Statistical average weight:

Class 1     32kg

Class 2     40kg

Class 3     52kg

Class 4     64kg

Class 5     71kg

After the registration procedure is finished, a list of drivers for each team shall be posted. The list must contain:

- Race number;
- Name and surname;

- Sex;
- Date of birth (day/month/year);
- Verified weight and ballast required;
- Class.

For classes 1 - 3 also the name of the co-driver must be indicated

### **3.8 - Team representative meeting**

After finishing the registration procedure, a Team Representative Meeting must be held.

Attending the meeting is mandatory for every team representative, coach and jury member.

### **3.9 - Inflatable buoys**

Inflatable buoys are to be used, which will have a minimum height of 70 cm (min. 60cm above the water level), and which will be marked with vertical stripes to easily show any possible rotations caused by touching of the buoys.

All gates must have a width of 2,5m between buoys.

The following colours are used for the buoys:

- Red                    for gates and turns;
- Yellow                for final gates;
- Blue                    for the final turn for class 5;
- White                  for start-finish.

### **3.10 - Flags**

The following flags with a size of 80cm to 80cm are used:

- Green start (departure);
- Yellow danger on the circuit;
- Red stopping of the race;
- Chequered finish;
- Black-raised by buoy marshalls when competitor touches the buoy.

## **4. RACE PROCEDURE**

### **4.1 - General**

Each race includes 3 stages:

- 1<sup>st</sup> stage: free practice (point 4.2);
- 2<sup>nd</sup> stage: manoeuvring (point 4.3);
- 3<sup>rd</sup> stage: parallel slalom with final races (point 4.4);

Drivers run against the clock.

All the rules will come into force and all penalties can be applied right from the moment of leaving the starting pontoon.

Timekeeping starts after crossing the starting line with the front of the boat (after getting the starting permission with green flag) and ends by crossing the finishing line by front of the boat again.

All drivers must complete every stage according to the drawings and guidelines for the relevant class. There should never be more than one boat on each racecourse at a time.

In classes 1 - 3 the drivers sit or kneel in the boat, the drivers in classes 4 and 5 sit on the jockey seat.

It is permitted to hold the sides of the boat to increase stability and safety.

The start must be performed without additional touching of the starting pontoon with the boat.



Getting ashore: after passing the finishing line a boat must land smoothly within the designated area on the pontoon.

## **4.2 - Free practice**

Free practice is mandatory for every driver.

The manoeuvring racecourse is laid out for the practice on the water.

The driver must practice both circuits, manoeuvring and slalom, according to the race schedule.

The organizer shall determine the timing and duration of the free practice in the race schedule.

The organizer shall ensure that every team will have proportionally the same time for practice, depending on the number of its drivers.

Free practice must be run with the same type of boats and engines which will be used for the 2<sup>nd</sup> and the 3<sup>rd</sup> stage and on the same racecourses.

Training order must be determined by drawing lots per country and a team must be informed about this order in advance.

Training is prohibited at the race venue during the week prior to the race. The water area shall be closed until the Friday of the first scheduled training.

## **4.3 - Manoeuvring**

Manoeuvring consists of:

- Tying knots (point 4.3.1);
- Driving on the manoeuvring racecourse (point 4.3.2).

**4.3.1** Every driver must show his skill in tying the following knots (see addendum):

- Reef knot;
- Bowline;

- Half-hitch;
- Clove-hitch.

The maximum time limit for tying each knot is 60 seconds, beyond which the knot will be considered as improperly done. The driver must raise his arm, after each attempt, when he considers the knot is done.

**4.3.2** Every driver runs the manoeuvring course relevant for his class (see attached drawings).

Each driver is allowed 2 attempts, run consecutively. Both attempts will be performed on the same course, with the same boat and engine - within each class.

***The jury can decide another starting order/system in manoeuvring. If there is a risk of unequal conditions for the drivers caused by significant changes of weather (or similar).***

Drivers in classes 4 and 5 shall perform a man-over-board manoeuvre.

The boat must approach the mark with its left side during this manoeuvre and must be completely stopped (for example by using reverse gear).

Backwards motion of the boat is not allowed.

After the boat has come to a complete stop the driver raises a lifebuoy (or similar) over his head with both hands and puts it down on the designated mark without throwing it or dropping it down and then continues the course.

Failing to perform a correct man-over-board manoeuvre in the first attempt will lead to a second attempt, but the boat is allowed to move forward only.

#### **4.4 - Parallel slalom**

Parallel slalom is run on the course as shown in the attached drawing.

Two drivers from the same class shall start at the same time, each running on a separate racecourse.

Each driver shall have two attempts - the drivers shall change boats and courses for the second attempt.

Times from both attempts are counted up, adding penalty seconds (if any) and the driver is awarded U.I.M. points for his ranking (point 318.01).

The four drivers having the highest score in each class shall participate in the semi-finals and finals.

Pair setting for the semi-finals is according to the personal number of the drivers.

Each semi-final participant shall again have two attempts. The drivers shall change boats and courses for the second attempt.

The semi-final results are determined as mentioned above and the pair setting for the finals is as follows:

- Drivers with 1<sup>st</sup> and 2<sup>nd</sup> highest scores in the semi-finals compete for the 1<sup>st</sup> and 2<sup>nd</sup> place;
- Drivers with 3<sup>rd</sup> and 4<sup>th</sup> highest scores in the semi-finals compete for the 3<sup>rd</sup> and 4<sup>th</sup> place.

## **4.5 - Restarting**

Restarting of the engine must be done made by the driver himself - in categories 4 and 5; for lower classes (1 - 3) the co-driver's assistance is allowed.

The driver must finish the race after restarting, in order to be allowed to submit a protest to the O.O.D. If the driver is not able to restart the engine himself, he must raise his arms in order to be assisted by the rescue.

The O.O.D. decides if a restart is allowed. If the O.O.D. decides to allow a restart, it must take place immediately.

## 5. POINT SYSTEM, RESULTS AND PENALTIES

### 5.1 - Point system

The U.I.M. pointing system to be used is:

1- 400 points	8- 53 points	15- 7 points
2- 300 points	9- 40 points	16- 5 points
3- 225 points	10- 30 points	17- 4 points
4- 169 points	11- 22 points	18- 3 points
5- 127 points	12- 17 points	19- 2 points
6- 95 points	13- 13 points	20- 1 points
7- 71 points	14- 9 points	

Drivers must complete the relevant stage and cross the finishing line in order to be classified for the stage.

The 2<sup>nd</sup> and the 3<sup>rd</sup> stage will be regarded as separate championships.

At the end of the 3<sup>rd</sup> stage, points of the 2<sup>nd</sup> and the 3<sup>rd</sup> stage will be added up.

An overall title in the individual competition will be awarded to the three drivers of each class who have the highest scores from the sum of the 2<sup>nd</sup> and the 3<sup>rd</sup> stages.

The final results for the team competition are determined by the total number of points of all drivers, divided by the number of participants of this team. (average points of the team).

### 5.2 - Results

Results for each class and stage must be posted as soon as possible (and never more than 1 (one) hour after the last driver of that class has finished the relevant stage) in a clearly visible place (as announced in the drivers meeting).

All results must be signed by the O.O.D. and must show the time of posting.

The results of each race must be organized separately in each stage in columns showing clearly:

5.2.1 Manoeuvring: knots test penalties, 1<sup>st</sup> attempt times, 1<sup>st</sup> att. penalties, 1<sup>st</sup> att. times including penalties, 2<sup>nd</sup> attempt times, 2<sup>nd</sup> penalties, 2<sup>nd</sup> attempt times including penalties, best times including knots test penalties, ranking, U.I.M. points.

Disqualification shall result in zero (0) points for the attempt.

5.2.2 Parallel slalom preliminary heat / semi-finals / finals: 1<sup>st</sup> attempt times, 1<sup>st</sup> att. penalties, 1<sup>st</sup> att. times including penalties, 2<sup>nd</sup> attempt times, 2<sup>nd</sup> penalties, 2<sup>nd</sup> attempt times including penalties, 1<sup>st</sup> and 2<sup>nd</sup> attempts combined times including penalties, ranking, U.I.M. points.

If a disqualification occurs in parallel slalom, the driver concerned shall be disqualified from the whole stage because he does not have the required two valid attempts.

5.2.3 Individual competition / General: manoeuvring overall U.I.M. points, parallel slalom overall U.I.M. points, U.I.M. combined points ranking.

5.2.4 Team competition: manoeuvring 3 best results / U.I.M. points (identification of the relevant drivers and classes), parallel slalom 3 best results / U.I.M. points (identification of the relevant drivers and classes), U.I.M. combined ranking.

5.2.5 Prize giving: The three best drivers in Manoeuvring (stage 2), Parallel slalom (stage 3), Individual competition and in Team competition are awarded by prizes. The organizer arranges the prize giving.

5.2.6 Dead-heat situations:

Manoeuvring - if two or more drivers have the same time in their best attempt (including knots and driving penalties), the driver with the better added attempt time (including penalties for both attempts) will be ranked higher.

If one of the drivers has only one valid attempt, he will be ranked lower.

Parallel slalom - if two or more drivers have the same added times from their two attempts (including penalties), the driver having the better single attempt time (including penalties) from either his first or second attempt will be ranked higher.

If there is still a dead-heat situation and a decision is required in order to set up the semi-finals or finals, the drivers having the same time must re-run both attempts. After running again only the time of the re-run will be taken into account.

Individual competition - if two or more drivers have the same combined number of points from 2<sup>nd</sup> and 3<sup>rd</sup> stage, the driver having the best combined times, i.e. the sum of his better manoeuvring attempt (including penalties) and both his parallel slalom attempts (including penalties) - will be ranked higher.

Team competition - if two or more teams end up having the same sum of U.I.M. points in the team competition, the sum of points of 1<sup>st</sup> places are added, if the dead heat situation continues, the same procedure must be followed for the 2<sup>nd</sup> place until a winner can be defined. This is only possible if both teams have enough drivers to be taken into account.

If any of the above mentioned solutions would not define a winner, there will be a dead-heat result.

### 5.3 - Penalties

For the race courses the following penalties are to be applied:

- |  |              |
|--|--------------|
| - Additional touch of the starting pontoon   | 5 seconds    |
| - Bumping the landing pontoon  | 10 seconds   |
| - Touching of a buoy   | 10 seconds   |
| - Not passing the gate with the full length of the boat                                      | 20 seconds   |
| - 2 <sup>nd</sup> and 3 <sup>rd</sup> attempt each element of the race course (each attempt) | 10 seconds   |
| - 4 <sup>th</sup> attempt of the racecourse  | disqualified |

- Improperly done knot (each)	5 seconds
- Standing during manoeuvring or parallel slalom	disqualified
- Sitting on the side of the inflated boat, or bending	disqualified
- Boat did not stop at the mark during the man-over-board manoeuvre	10 seconds
- Boat goes backwards during the man-over-board manoeuvre	disqualified
- Raising the safety belt with one hand	5 seconds
- Not raising the safety belt not above the head (i.e. lower than drivers head)	10 seconds
- Putting down the safety belt with one hand	5 seconds
- Dropping or throwing the safety belt on the mark	10 seconds
- Second attempt to raise the lifebuoy	10 seconds
- Error doing the circuit (except above mentioned ones)	disqualified

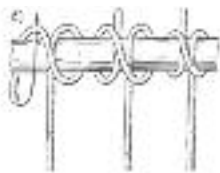

Clove hitch



Reef knot



Half hitch

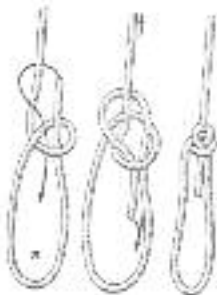

Bowline



Course scheme of the children's powerboat competition in river section "Towards Future"

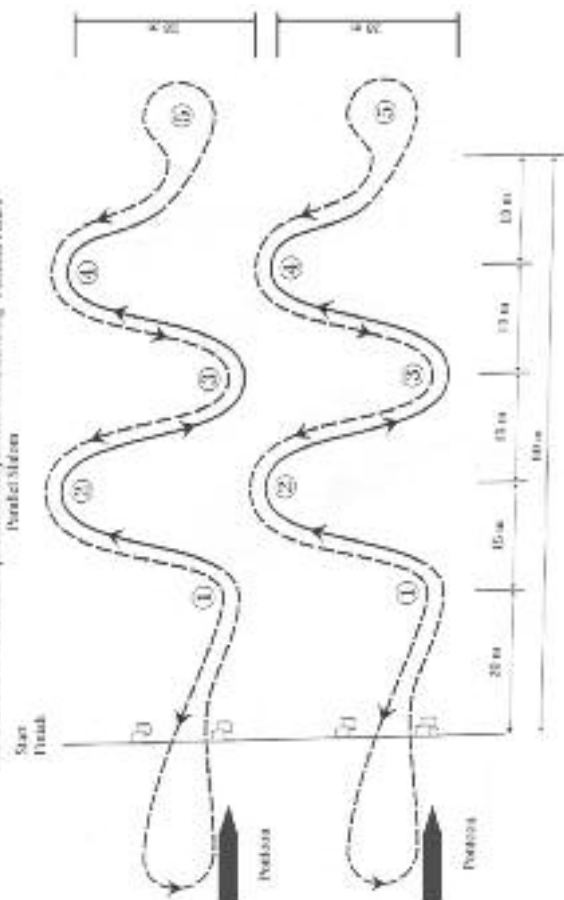

Departure - start line - along the course through the gates 1, 2, 3, 4, 5 - turning behind the gates 3 - again from station through the gates 5, 4, 3, 2, 1 - finish line - return to postlock - mooring

Course scheme of the children's playground in measuring "Tornado 3 square"

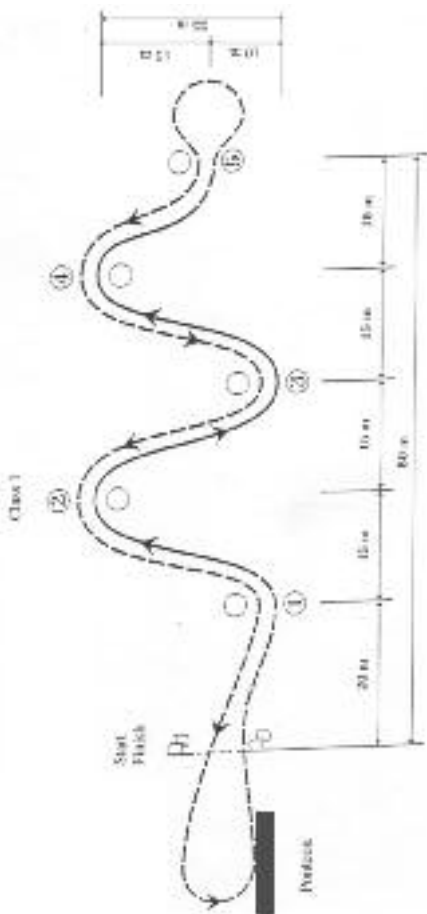

Direction - start line - along the course through the gates 1, 2, 3, 4, 5 - turning behind the gates 5 - again back section through the gates 5, 4, 3, 2, 1 - finish line - return to position - meeting

Course scheme of the children's pre-school competitions in mini-sporting "Tornado Funnel"

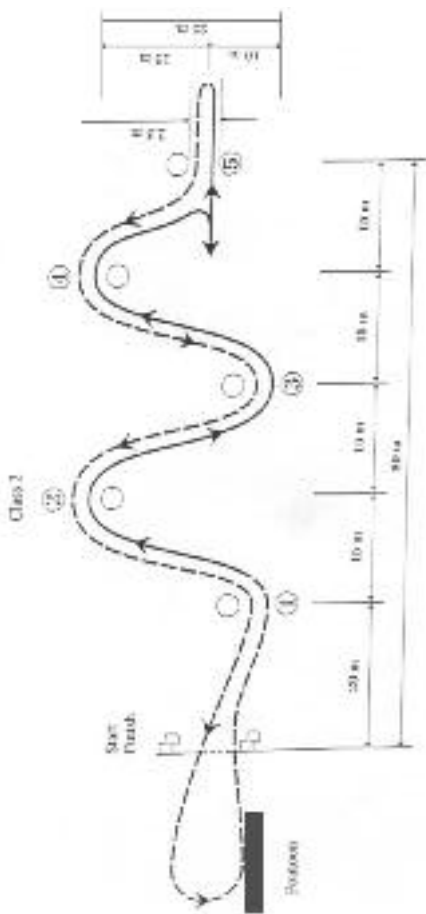

Explication - start line - along the course through the gates 1, 2, 3, 4 - by ascending to the gates 5 - again from another through the gates 6, 4, 3, 2, 1 - finish line - return to postbox - moving

Course schedule of the skater's powerboat competitions in measuring, technical return

Class 5

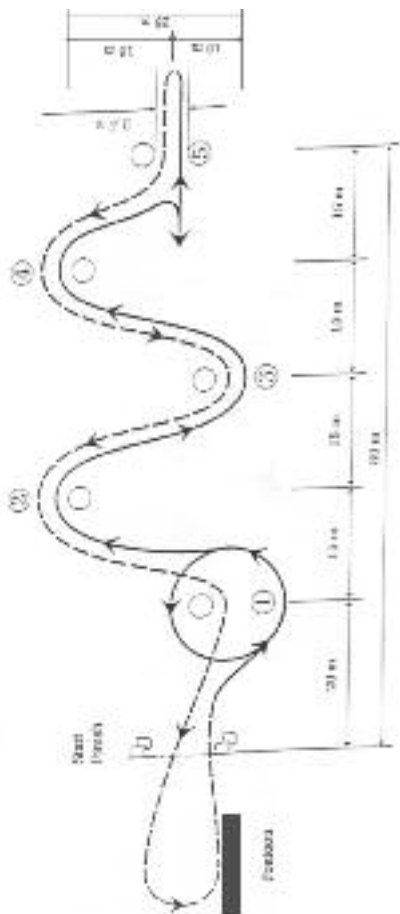

Requirement - start line - diameter of the gate 5 (the gate 1 are on the left side of the boat) - along the course through the gates 2, 3, 4 - by returning to the gate 5 - again there exercise through the gates 5, 4, 3, 2 - finish line - return to portroom - measuring

Course scheme of the children's preschool competition to maneuvering "Vertical board"

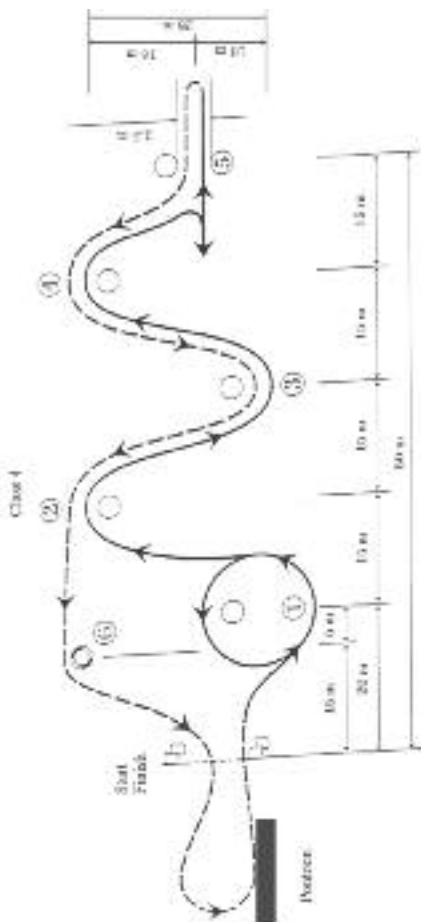

Departure - start line - below of the gates 5 (the gates 1 are on the left side of the boat) - along the course through the gates 2,

3, 4 - by averting to the gates 5 - again from motion through the gates 5, 4, 3, 2 - maneuver "run over-board" at buoy 6 -

dash line - refers to participant - maneuver

## Course scheme of the children's postural competences in mastering "Zigzag Future"

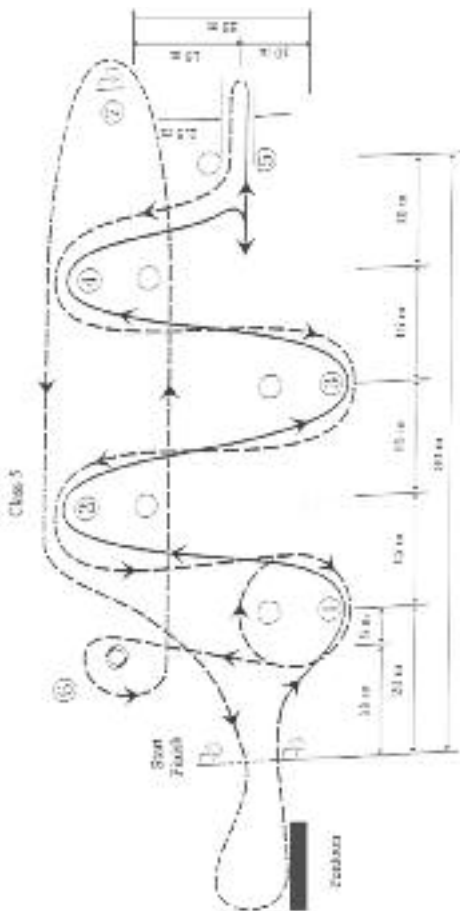

Duplicate - start line - along the course, turn around the poles 1, 2, 3, 4 from outside - by reversing on the poles 5 - again from outside, turn around the poles 4, 3, 2 from outside - inside (near of the poles 1) (the poles 1 are on the right side of the boat) - maneuver "man over-board" at trace 6 - speed reset from inside poles 2 and 4, round barrier 3 and from outside (poles 4 and 2) - finish line - return to previous - tracing.

## **501 - MEASUREMENT CERTIFICATE**

A boat is not allowed to take part in an international race without a measurement certificate, issued by a National Authority, made up in the native language and in English according to the official U.I.M. model. The certificate is valid for one year. It can be renewed without re-measuring, provided the rules for the relevant class have not been changed.

When measuring a boat with a reinforced cockpit, all specifications in rule 509 must be checked.

### **501.01**

Each National Authority stipulates the cost of measurement and the duration of the validity of the certificate.

The request to obtain a measurement certificate must be accompanied by the homologation file of the motor, if such is requested for the devices being used.

### **501.02**

Any owner who has made alterations affecting the measurements in the certificate must notify his National Authority at once. Non observance of this rule invalidates the certificates. The National Authority re measures the boat at the owner's expense. Any boat that has been altered but not re measured is not allowed to race.

### **501.03**

Any international measurement certificate must be as described hereafter, and must be adopted and used by all National Authorities and the U.I.M.

### **501.04**

The serial number of the motors may be omitted in the measurement certificate.

<b>UIM</b> Union Internationale Motonautique		<b>NA</b> National Authority	
<b>MEASUREMENT CERTIFICATE</b>			
NUMBER	CLASS	SERIE	
Owner _____			
Club _____			
Boat Name _____			
<b>SAMPLE</b>			
Measurer _____			
National Authority _____			
Date _____		Valid till _____	



## HULL

BUILDER \_\_\_\_\_ YEAR \_\_\_\_\_

DESIGNER \_\_\_\_\_

MATERIAL \_\_\_\_\_

LENGTH	BEAM	WEIGHT	COCKPIT		
			LENGTH	BEAM	DEPTH

**ENGINE**

**SAMPLE**

BRAND \_\_\_\_\_

TYPE \_\_\_\_\_ YEAR \_\_\_\_\_ N? \_\_\_\_\_

HOMOLOGATION N? \_\_\_\_\_

### SPECIFICATIONS

CYCLE \_\_\_\_\_ N?

CYLINDER \_\_\_\_\_ N?

BORE \_\_\_\_\_ mm

STROKE \_\_\_\_\_ mm

CYLINDER VOLUME \_\_\_\_\_ c m<sup>3</sup>

**501.05**

No blank certificate may be issued by National Authorities. Documents must be completely filled in with all particulars pertaining to the series for which the boat is measured. The certificate must also be signed and stamped by the National Authority.

**501.06**

Drivers need only supply and measurers need only check such particulars as are applicable to the class of boat.

**501.07**

Anyone involved in the design, building (manufacturing or marketing) of a hull or motor in any other way has an interest in a certain boat is not to measure the boat.

**501.08**

All measurements should be taken at least twice. Measurements should remain within the limits provided for on the homologation sheet.

**501.09**

The owner of a vessel pays all fees and expenses for measuring his boat and/or motor(s).

The measurement certificate is only to be handed over when all dues have been settled by the owner to the National Authority.

**501.10**

When a re measurement is made at the request of the National Authority, the expenses and fees for such re measurement are paid by the National Authority if the first measurement is upheld.

## 501.11

A log book is mandatory for all boats equipped with reinforced cockpit, to be filled out by the race scrutineer indicating the race location, date, and if any damage occurred to the cockpit or boat. It will be part of the measurement certificate.

## 502 - INSPECTIONS

### 502.01

Hulls, motors, fuel, accessories and equipment, subject to restrictions regarding dimensions or other characteristics, must be submitted for verification.

All race boats must be inspected before going in the water, and as a help to the inspectors they may use the recommended minimum check list

### PRE RACE INSPECTION

At every race meeting, the boats must be inspected before going in the water due to safety reasons.

Minimum check list for Pre-race inspection of race boats

BOAT NUMBER	U.I.M. art.
Life jacket	205.06/509.04
Crash helmet	205.07
Lifting eyes and slings	205.12
National flag	206.01
Boat number on boat deck and under cockpit	206.02/509.19
Mooring eye	503.01
Paddle (not required in boats with reinforced cockpits)	503.01

Flotation	503.01/509.02
Throttle & ignition cut off	503.03
Steering drum and steering cables	503.05
Rigging of fuel systems	503.05
Rigging of electrical systems	503.05
ID plate on cockpit	509.01
Seat belts and belt buckle (check for wear)	509.03
Driver fitting in cockpit	509.05
Water deflector	509.07
Energy absorbing padding in cockpit	509.08
Sharp edges in cockpit	509.09
Removable steering wheel	509.10
Rear view mirrors	509.11
Motor shut off switch outside of cockpit	509.12
Air vents	509.14
Water inlet holes in back of boat	509.15
Bottom of cockpit coloured orange	509.19
Oil absorbing carpet	703
Main power switch (electrical)	Formula Rules
U.I.M. Sticker for all titled events	Formula Rules
Oil	508.07

Drivers must be able to show:

- a valid license;
- a valid measurement certificate for the relevant class;

- a complete homologation sheet (if mentioned in the measuring certificate);
- all pages should have a U.I.M. or N.A. original stamp;
- a copy of the boatbuilder's U.I.M. registration for reinforced cockpits;
- a valid immersion test certificate (§ 205.05) for boats with reinforced cockpits;
- a current U.I.M. rulebook;
- for drivers with a physical handicap, a doctors written approval that the driver may race (mentioning any special conditions).

## **502.02 - MOTOR INSPECTION**

Verification of motors in restricted series is carried out according to the facts contained in the homologation file.

At world record runs, world championships and continental championships, inspection of the winning motor is compulsory.

Inspections may also be done whenever found necessary at all international and national events.

At all Continental and World Championship events hosting "low emission" engines a technical representative of each brand of engine entered may be enlisted to provide electronic verification of legality to the Chief Technical Inspector of the event. The representative must report exclusively to the Chief Technical Inspector.

The following procedure is mandatory for these inspections:

1. Check that the motor type code and visual appearance conforms with the motor homologation sheet.
2. The measurements stated in the homologation sheet must be checked on the motor. If the results are within the specified tolerances the motor should be accepted as legal. Only adjustments to meet dimensions shown in the homologation sheet are allowed.
3. When ports in cylinders are adjusted to the dimensions specified in the homologation sheet, material may only be removed in the

specified opening to a depth of 10 mm, to match the shape of the original adjacent connecting passage (channel) outside the adjusted port opening. This also applies to other openings in the motor for which the dimensions are specified in the homologation sheet.

4. Parts not specified with measurements in the homologation sheet shall only be checked by visual comparison with standard parts. As the actual manufacturing tolerances are not published, small differences between the inspected part and the reference part must be accepted.
5. Cylinder dimensions and compression volume are measured when the motor is cold. Allowance is made for the carbon and oil present in the combustion chambers. Checking is to be done with oil. A large scale graduated cylinder or burette with adequate orifice is to be used.
6. Inspection procedure for the low emission engines will also be clarified in the homologation sheet.

### **502.03**

The driver must report with his boat at the inspection and must comply with the rules of the organising race committee.

### **502.04**

Technical inspectors have the right, once races are over, to carry out all the checks they consider necessary, even when inspection has taken place before practice, and they have the right to inspect as they think fit.

The post-race inspection should be about speed and power enhancing matters.

At any time during an event, the technical inspector, the O.O.D. or the U.I.M. commissioner reserves the right to change a competitors existing ECU/CDI unit with a standard OEM unit as supplied by the U.I.M.

If a competitor refuses this request, they will be immediately disqualified from the event, without right of protest.

### **502.05**

Drivers are at all times responsible for the condition of their boat (hull, motors, accessories, equipment, etc.).

### **502.06**

Errors, if any, on the part of the manufacturer, builder, mechanic or even the previous owner do not justify non conformity with the rules.

### **502.07**

A driver who does not comply with the decisions or instructions given by the Technical officers, or who infringes any rules which it is the duty of the technical officers to check is not allowed to start in the race, or should he have raced shall be disqualified and reported to his National Authority, for possible further penalties.

A Breach of the technical rules, will result in a disqualification from the entire race or heat. Exception is that lost or broken engine parts, required by rules or homologation, result in disqualification only for the relevant heat if repaired or replaced for subsequent heats.

Foreign drivers are to be reported to their own N.A. through the N.A. of the organising country.

Each N.A. must then inform U.I.M. of further penalties, or reasons why no further penalty has been given by his N.A.

A driver who refuses his boat and/or motor to be inspected after a race shall be penalised as severely as for a serious infringement of the technical rules.

If this occurs at a international titled event, a mandatory penalty will be that the driver will loose his right to participate in international events for 12 months.

## 502.08

It is prohibited to change the crankcase, the hull or its sponsons after qualifying races (if any) and after the start of the first race/heat.

These items can be changed during or after the timed trials, in this case the times achieved with the items used before the change is void.

The replacement engine will require sealing and the exchanged boat or sponsons, will be considered as a new entry, requiring full scrutineering. If no timed practise opportunity remains, the boat will start from the end of the grid.

Any outside assistance on the race course, for repairs or any other reason will result in disqualification.

If any repairs can only be effected outside the boat park, they must be carried out in the presence of a Technical Officer.

## **503 - EQUIPMENT - PEOPLE ABOARD MOTORS**

### 503.01

Every boat must be fitted at the bow with a towing eye, and every reinforced cockpit boat must be fitted at the bow with two mooring eyes, one at the top and one at the bottom which must be strong enough to support the boat if it sinks and to make towing possible.

One or two oars or adequate paddles, adequately secured and stowed, so that they are immediately available, are to be on board. Boats with reinforced cockpits do not need to have oars or paddles.

***In O-classes up to and including 350 and OSY 400, the colour of the paddle shall be yellow or orange, or similar fluorescent colour. This is to be used as a warning signal.***

Every boat must have adequate buoyancy to ensure that it floats in case of an accident. This buoyancy shall be equivalent to a volume of 0.055 m3 of foam per 100 kg. of boat weight. If a reinforced cockpit is fitted, at



least one half of this volume must be securely attached to the cockpit structure. Any foam is to have a maximum density of 30 kg/m<sup>3</sup>.

The flotation provided by the airbag is not to be included in the calculation for required flotation.

### **503.02 - WINDSCREEN**

Boats must be uncluttered and the windscreen if fitted must be easily removable to present no obstacle to the driver getting free, and to not impede lifesaving and salvage operations.

The edges of the coamings and the windscreen must not be sharp and must be lined with rubber or other similar material to avoid injuries in case of accident.

### **503.03 - AUTOMATIC THROTTLE SHUT-OFF**

All boats must be fitted with an efficient automatic throttle shut-off device as well as an automatic device in the ignition circuit which will stop the motor if the driver is thrown out.

Boats with reinforced cockpits do not need to be fitted with this kind of ignition shut-off device.

The device must be clearly visible, as must be the link to the driver. The link must be short enough to be efficient.

The system must be working at all times during a race, practice or trials.

A driver who does not conform is disqualified in a race or is made to pay a fine in case of practice or trial runs.

Lanyard connection to the life vest is required to shut off the fuel on boats with electric fuel pumps.

### **503.04**

During a race, the boat must have onboard all the equipment required by the Race Committee in the detailed instructions contained in the advance programme.

### **503.05**

All attachments, navigation lights, hand holds, steering gear, pulleys, fairleads, cleats and anchor eye, etc. must be bolted to the hull.

### **503.06**

In all series, there must be only one driver per boat.

The Race Committee may rule otherwise in the advance program for long distance races.

### **503.07 - PISTON MOTORS**

Reciprocating piston motors are to be fitted on boats of the international series.

The total cylinder capacity of the motor or motors forms the basis for eligibility in the corresponding classes.

The motors may be of the two stroke types. They may have carburettor(s) or fuel injection.

### **503.08 - ROTARY MOTORS**

Rotary motors with trochoidal rotors are admitted on the basis of an equivalent cylinder capacity.

The rotary motor capacity is twice the volume determined by the difference between the greatest volume and the least volume in the working chamber.

## 503.09 - SUPERCHARGING

When the motor includes a device used for supercharging it, the nominal cylinder capacity is to be multiplied by 1.4. and the boat will pass into the class corresponding to the calculated volume resulting from this operation. The supercharger must be a standard part of the motor. A dynamic air inlet for ducting the atmospheric air toward the motor's air intake is not considered as a supercharging device.

## 503.10 - FINS

Fins are not allowed to be retractable underway.

## 503.11 - ELECTRICAL ISOLATION

All boats, with batteries, must have an isolation switch as close to the positive terminal of the battery(ies) as practicable (negative terminal if positive earth system).

The opening handle of the switch must be easily accessible on the deck or other surface of the boat on the port side between 1 to 3 metres forward of the stern.

This switch must be marked with a red flash + and the "On/Off" positions shown.

## 503.12 - BALLAST

***These ballast rules are valid for all Circuit classes excluding the classes with specific rules for ballast (Formula Future) which are already applied.***

***The ballast must have the necessary strength to remain fixed where positioned.***

***The ballast must be on the inside of the hull fixed with clamping suitable for the race.***

***It must be possible to remove ballast for inspection.***

***The maximum allowed ballast weight is 10% of the specified minimum weight for each individual class (mentioned in the rules for each class);***

***For the classes where there are mentioned the minimum weight of the boat and the minimum weight of boat with driver, the maximum allowed ballast weight is 10% of the specified minimum weight without driver to reach this minimum weight, plus possible ballast weight that is necessary to reach the specified minimum weight with driver.***

## **504 - NOISE REDUCTIONS**

### **504.01**

The use of an efficient device to attenuate the noise is compulsory.

A race organiser shall have at hand a sound level meter as described below as well as personnel trained in its use.

It is recommended that associated National Authorities obtain such meters and lend them to race organisers when needed.

### **504.02**

The noise level must not exceed levels listed below, except for A- and TR-serie boats.

### **504.03**

The noise level is measured by means of a precision sound level meter which conforms to the specifications laid down by I.E.C. and A.N.S.I., using the "A" weighting and set to slow response. The registering microphone is placed at a distance of 25 m 90 degrees to the course of the boat with no interfering objects within 25 m. The boat must pass the microphone at top speed.

The measurements must be carried out while the boat approaches the microphone and while moving away from the microphone. The measuring must start when the boat is minimum 100 m before the closest point on the course to the microphone and continue until the noise level has dropped considerably from the measured value.

Neither of the measurements is to exceed 91 dB(A) with a 2 dB(A) tolerance for motors up to 750 cc, and 91 dB(A) with a 4 dB(A) tolerance for motors above 750 cc.

Only for motors up to 750 cc, without water pump

If the above method is not practicable, reference measurements may be made with the boat on dry land, the motor running under no load at a mean piston speed of 13 m/sec. The microphone must be placed 0.5 m from the exhaust orifice and at a height of at least 20 cm above the ground. The maximum noise level, using a meter as above is to be 101 dB(A) with a 2 dB(A) tolerance. This level is experimentally determined and may be changed.

## **505 - ENGINE HOMOLOGATION**

### **505.01 - RESPONSIBILITY**

*COMINSPO*R*T controls the homologation process and appoints a POWERTRAIN committee to carry out the various processes. POWERTRAIN is composed of persons appointed from the membership of COMINSPO*R*T and COMINTECH and, if needed, outside experts.*

### **505.02 - PROCESSES**

*U.I.M. establishes two processes depending on the entity initiating the homologation request.*

### **505.02.01 - PROCESS #1**

*An engine manufacturer applies for an engine homologation for competition in certain U.I.M. classes.*

### **505.02.02 - PROCESS #2**

*COMINSPOORT or COMINOFF requests homologation of an engine for competition in certain U.I.M. classes.*

### **505.03 - HOMOLOGATION APPLICATION - PROCESS #1**

*Engine manufacturers are invited annually to apply to the U.I.M. for engine homologation via their affiliated U.I.M. National Authority of the country of engine manufacturer. Homologation application must be made using the electronic homologation forms available from the U.I.M. Secretariat.*

### **505.04 - MINIMUM PRODUCTION QUANTITIES**

*The required number of engines manufactured prior to homologation is to be verified by the manufacturer and endorsed by the National Authority of the country of manufacture. If insufficient numbers of engines have been manufactured at the time of homologation, a written certificate, witnessed by a practicing lawyer, of the firm intention to manufacture the specified numbers is required from the manufacturing company which must clearly state the completion date of manufacturing schedule to meet the required minimum production numbers.*

*Minimum required quantity of outboard engines is 250 units.*

*Minimum required quantity of offshore inboard engines is (30).*

*In Process #2, no manufacturer statement or statement of intention is required.*

## **505.05 - DEADLINE FOR APPLICATION**

*In Process #1, Application for the request of homologation of an engine must be received by the U.I.M. Secretariat by close of the last business day before the relevant year's GA, to be considered for validity commencing 1<sup>st</sup> April in the following year.*

*In process #2, COMINSPOORT must direct POWERTRAIN to complete the homologation of a candidate engine at the COMINSPOORT meeting during the General Assembly of any given year to be considered for validity commencing 1<sup>st</sup> April in the following year.*

## **505.06 - APPROVAL OF APPLICATION - PROCESS #1**

*An application for homologation, running production change or extension of validity will be considered by COMINSPOORT (or, in the case of engines designated for use by the offshore category, COMINOFF). This commission will determine if the candidate engine complies with the rules of the class of racing for which the engine is designated (i.e.: availability, performance level, suitability).*

*Once an application for homologation, running production change or extension of validity of a candidate engine is deemed acceptable for a given class by the relevant commission, the inspection and verification procedure (or administration of the running production change or extension of validity) will commence.*

## **505.07 - INSPECTION VERIFICATION PROCEDURE**

*At a time and place agreed upon by the U.I.M. COMINSPOORT's Powertrain committee and the entity requesting homologation, a production example of the candidate engine; all its components; and any relevant inspection tools will be examined to complete and verify the declarations in the homologation file as applied.*

*This inspection must be completed before 1<sup>st</sup> April for the homologation to be valid for commencement in that year.*

***In Process #2, Powertrain will procure the example engine; examine it; complete the relevant documentation; and dispose of the engine (all at U.I.M. expense).***

***The homologation becomes valid when all correct and completed documentation including the finalized homologation document has been received by the U.I.M. Secretariat. This must be before 1<sup>st</sup> April for the homologation to be valid for commencement in that year.***

## **505.08 - TERM OF HOMOLOGATION**

***A homologation remains valid from the date of completion through to 31<sup>st</sup> December of the tenth year of validity.***

## **505.09 - ANNOTATION OF VALID CATEGORIES**

***The final homologation file will display the specific U.I.M. power boating category(s) for which the engine is approved. The annotations will be made appropriately as follows:***

- CIRCUIT***
- OFFSHORE***
- CIRCUIT/OFFSHORE***

## **505.10 - HOMOLOGATION FILE COPIES**

***Copies of homologation files are obtainable from the U.I.M. office against payment of a nominal fee.***

***The copyright thus bought allows a National Authority to reproduce the file with as many copies as necessary for its drivers and technical services. A nominal charge may be levied for copies provided by the National Authority.***

***For restricted stock U.I.M. classes a homologation sheet is required for engine and propulsion units. This file is Valid only for the model***



*describer. Any model derived must be subject to a separate homologation.*

*A copy of the homologation sheet must accompany any engine, boat or accessory used in a class in which homologation is required.*

## **505.11 - RUNNING PRODUCTION CHANGES**

*Approval of application for running production change must initially follow the rules of 505.07.*

*An application for a running production change may be requested by a manufacturer at any time of the year, although its commencement will be dated from 1<sup>st</sup> April in the year applied for. Powertrain will confirm whether any requested change is acceptable as a running production change, or requires the engine model to be re-homologated. Modifications to specifications dictated by manufacturing or structural requirements are admitted, but not those primarily aimed at improving performance. (as a guide, any changes or accumulation of changes likely to increase power by more than 5%, or the speed performance corresponding to more than 5% increase above that given by the original homologation specifications, may be grounds for re-homologation).*

*An approved running production change will be announced on the U.I.M. Website and will be deemed legal for use in racing 30 days after the official date of approval.*

## **505.12 - EXTENSION OF VALIDITY**

*Extension of validity of an homologation is determined solely by COMINSPORT or/and COMINOFF.*

## **505.13 - RESPONSIBILITY FOR HOMOLOGATION EXPENSES**

*The expenses of inspection are to be borne by the U.I.M. in either process.*

***The verification inspector will be designated by Powertrain and his expenses (travel, hotel and meals) are to be reimbursed by U.I.M. It will be COMINSPOUR's intent to minimize costs by designating the nearest capable person as the inspector for each candidate engine.***

## **508 - FUEL**

### **508.01**

- 1) To maximise the equality of competition and to simplify the checking of conformity, organisers must arrange the supply of the same fuel for all competitors at all international titled events, except for classes O/125 to O/700 where the fuel is alcohol based (508.05). It does not of necessity have to be free of charge. It is also recommended for ordinary international events.

Organisers must announce in the advance programme.

The cost of fuel that they will be arranging, the octane number, the brand name of the supplier, and the logistic method of making it available, e.g. distribution tanker in the pits or organised shuttle service to a local fuel station operated by the local organiser. Drivers must provide suitable containers for such use, marked in accordance with appropriate international hazardous standards, and clearly marked with the boat race number.

Drivers must use the arranged fuel as provided and must not bring their own fuel to the event. Contravention of this rule will be penalised. Checks may be carried-out on arrival in the pits and during scrutineering.

### **508.02 - SPORTS ENGINE FUEL (S. T. P. E. - OSY400 - F1000 - F2 - F4 AND O CLASSES - O850 AND ABOVE)**

- 1) Fuel will be unleaded automotive gasoline only for use in non-racing automobiles equipped with catalytic converters.

- 2) Fuel may also be intended for sport engines supplied to the organiser by an international fuel company.
- 3) Fuel will have a minimum octane rating of 95 RON.
- 4) All fuels supplied must be in conformity with the minimum requirements of the engine manufacturers

### **508.03 - RACING ENGINE FUEL (F1 R CLASSES)**

- 1) Fuel produced by an international company for motor sports use. Octane rating to be minimum 100RON maximum 104RON. Unleaded fuel is preferred.
- 2) Aviation fuel AVGAS 100LL, may be used. (No longer allowed in EEC countries).
- 3) All fuels supplied must be accompanied by a data sheet.
- 4) All fuels supplied must be in conformity with the minimum requirements of the engine manufacturers

### **508.04 - DIESEL ENGINE FUEL**

- 1) The fuel must be a commercial grade for automotive or marine use, as obtained from normal roadside or marine service stations.

### **508.05 - ALCOHOL BASED FUEL**

- 1) The fuel must be Methanol (CH<sub>3</sub>OH) or Ethanol (C<sub>2</sub> H<sub>5</sub> OH)
- 2) The fuel may contain water (H<sub>2</sub>O).

***Any changes to the above rule must have the first implementation date of at least 3 years from being passed by General Assembly.***

## **508.06 - ADDITIVES**

- 1) Only lubricating oil for two stroke engines may be added to fuel. The use of any other additives is prohibited to either the fuel [carburent] or the air intake [comburant]

***Any changes to the above rule must have the first implementation date of at least 3 years from being passed by General Assembly.***

## **508.07 - LUBRICATING OIL**

- 1) Only two stroke engines that are not equipped with mechanical oil injection systems will be permitted to use fuel with lubricating oil pre-mixed in it.
- 2) The use of environment-friendly oil is recommended in pre-mixed fuel / oil.

## **508.08 - RANDOM TESTING OF COMPETITORS' FUEL**

- 1) Fuel samples taken at random from competitors during the event will be tested at the race venue, and may also be chemically analysed afterwards in the laboratory. The organizer must seal the sample of the fuel in a fuel approved can.
- 2) The entire installed fuel system may be dismantled, removed from the boat and inspected.
- 3) Gasoline supplied by an organiser will be tested at the start of an event to establish its test device value.
- 4) In the event that the organiser does not supply fuel and the competitors bring their own, each competitor's fuel will be checked. This will be part of the pre race scrutineering.
- 5) At an event where the competitor's fuel is used, it will be the competitor's responsibility to ensure that at least one litre of neat gasoline is always available for sealing as a sample.

- 6) The presence of illegal fuel at any time will result in the driver being immediately disqualified up to that point.

## **508.09 - TESTING PROCEDURES**

- 1) Gasoline fuel or fuel / oil mixture may be checked at any time using U.I.M. approved equipment and procedures. Meters and equipment will be calibrated each time in accordance with the U.I.M. fuel testing guidelines obtainable from the U.I.M. Secretariat.
- 2) Non-gasoline fuels will be tested in accordance with U.I.M. current procedures. Density test will be performed on non-gasoline fuels. Density of the fuel should be less than 0,830 kg/dm<sup>3</sup>.

## **508.10 - DISQUALIFICATIONS, PROTESTS AND APPEALS**

- 1) Any competitor's fuel when tested, and judged as illegal, from timed trials, heats or races will be disqualified up to that time.
- 2) The legality of the fuel is to be judged only by the U.I.M. commissioner, or if he is not present at the event, by the technical scrutineer, based on all tests and information available to him at the time.
- 3) Any further infringement of these fuel rules will lead to immediate Temporary Suspension (art. 406.07) from all of the event, where the infringement occurred.
- 4) Repeated violation of these rules the U.I.M. may sentence a stronger penalty.
- 5) Any disqualification must be followed by the sealing-up of two samples of the competitors fuel. Recommended amount of fuel by test labs - not less than 1 litre. No sample to be opened or disposed of unless the U.I.M. inform accordingly.
- 6) If the competitor protests or appeals his disqualification, he will have the right to have the samples checked using Gas Chromatography,

or similar tests to establish what components are present in the fuel sample. All costs incurred in this analysis will be paid by the competitor irrespective of the result.

- 7) If one competitor protests another competitor's fuel, there must be a factual basis for the protest, samples will be taken and tested. The protest must be accompanied by a fee of 250 € which may be used to defray the cost of the analysis
- 8) The result of the analysis which will confirm the presence of illegal additives or not, will be taken as final and cannot be appealed.

## **508.11**

### **Refuelling**

- 1) Refuelling is allowed only at places announced by the event organiser.

## **508.12**

### **Starting aids**

- 1) No chemical starter aids are permitted on the start pontoon except for alcohol based fuels.

## **509 - REINFORCED COCKPITS**

These rules provide only a minimum standard for reinforced cockpits. It is important that constructors continually develop cockpits beyond these minimum's and produce cockpits that exceed these standards.

The approved Newton standard for a cockpit is to be found from the cockpit registration number. A list of registration numbers and the corresponding Newton standards is available from the U.I.M. Secretariat and the U.I.M. website.

All new cockpits registered in U.I.M. classes (Except F1 and F2) will be registered for 10 years provided they meet the 3000 Newton Test and other current relevant cockpit rules ; provided that Cominsafe, Cominsport, Comintech and the Cockpit Committee agree that there are no new technologies that would significantly improve the safety of the drivers in these cockpits. The mandatory implementation date of exceptions must be fixed by these commissions for each affected class.

### **FOR OUTBOARD CLASSES UP TO 1500 CC OR (90 HP EPA) AND OTHER COCKPIT BOATS**

Any cockpit of 1000 Newton must be updated to 2000 Newton by the addition of enough composite material, to have 2000 Newton cockpit,  $1000 + 1000 = 2000$ . It is recommended to upgrade cockpits to 3000 Newton.

Any cockpit registered but without a 1000 Newton certification must be upgraded to 2000 Newton by a registered 2000 Newton or higher certified cockpit builder with the addition of at least 2000 Newton of materials and the addition of his cockpit certification number stating if it is a 2000 Newton or 3000 Newton upgrade.

### **FOR OUTBOARD CLASSES FROM 1501 CC OR OVER 90 HP EPA**

Any cockpit of 1000 Newton must be upgraded to 3000 Newton by the addition of enough composite material, to have 3000 Newton cockpit. All 2000 Newton cockpit boats are free to participate until further notice.

### **UPGRADING**

This upgrading on cockpit must at least be done on both vertical sides above deck, over the helmet area, over the leg area, the backplate, and the entire bottom. An approved cockpit builder who has passed the at least 2000 Newton panel test must do the upgrade.

Upon any upgrade completion, his cockpit registration number must be moulded or ground into the upgraded cockpit.

Cockpits must have two cockpit registration numbers, one for the original cockpit and one for the updated reinforcement. These two numbers must be written in the measurement certificate.

Cockpits built in 2002 and onward must have passed the 2000 Newton test.

Cockpits built in 2005 and onward, for outboard classes from 1501 - 2000 cc and upwards, must have passed the 3000 Newton test.

## U.I.M. COCKPIT TEST STANDARD

### Sample Construction Requirements

1. Sample quantity must be 3, one of which must include a sample of the joint/bonding of the cockpit halves, transverse to the length of the sample;

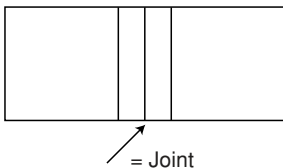

2. Trimmed sample size must be 100mm  $\pm$ 1.0mm wide x 800mm  $\pm$ 5mm long, with the width being parallel;
3. For fibre orientation the 800mm length being parallel with the bottom surface of the intended homologated cockpit;
4. Sample must be laminated on a flat surface using the same manufacturing process, materials and fibre orientation's as the intended homologated cockpit construction;
5. The sample must have a uniform thickness with no core crushing along any edges;
6. The sample must have one moulded face and the other face being unmoulded, the moulded face will be taken as being the external surface of the cockpit during testing;
7. The sample must be representative of the thinnest lay-up of the safety cell;



8. The sample and cockpit must be manufactured using balanced or unbiased materials.

### **Sample Test Method**

1. The sample will be supported across its full width perpendicular to the 800mm edges by two parallel 25mm Steel bars at a distance of 500mm apart. The load will be applied equally through two 25mm Steel bars, each a distance of 167mm parallel from each support;
2. The moulded face of the sample will have the load applied and the unmoulded face will support the sample;
3. The load will be applied at 0.4mm/sec and the deflection will be measured at the two 25mm Steel bars applying the load within 2 minutes.

### **Sample Test Requirements**

1. The sample when loaded with a force of 3000N must have no more than a maximum deflection of 25mm without the sample failing;
2. The sample weight in grm/m<sup>2</sup> will be calculated, skin thickness and sample thickness will be measured to enable inspection and comparison of damaged homologated cockpits;
3. Further non-destructive test analysis methods maybe used to compare test samples with homologated cockpits during the life of each cockpit.

### **Sample Manufacturing Information Requirements**

1. Ply laminating sequence (stating which ply is the moulded face);
2. Ply materials;
3. Ply weave styles;
4. Ply material weight in grm/m<sup>2</sup> (dry weight ie. without resin);
5. Ply orientation (where 0° is parallel with the 800mm edges);
6. Core material and density in lbs/ft<sup>3</sup> or kg/m<sup>3</sup>;
7. Manufacturing method (stating vacuum, pressure and temperature);

8. A 100mmx100mm sample of all materials used (resin samples not required).

Samples as per sample construction requirements must be sent to the following address:

Siegfried Boettle  
1283 Blackburn Avenue  
60031 Gurnee, Illinois USA  
Tel. + 1 847 6235845 Fax + 1 847 6235826  
E-mail: ziggy@boettle.org

## **509.01**

Any boat having a restraint system (driver harness) must have a reinforced cockpit complying with § 509, even if a reinforced cockpit is not mandatory in its class.

Matters relating to cockpits/deformable structures shall be dealt with by the cockpit working group.

Experts may be co-opted when required.

The manufacturer of any reinforced cockpit will submit his name, or company name if applicable, and completed U.I.M. reinforced cockpit questionnaire to his National Authority. and thence to U.I.M., before that cockpit will be allowed to compete. The manufacturer's name, type designation, date of manufacture and registration number must be permanently moulded into a visible place on or in the reinforced cockpit. If this is not moulded in, a scrutineer shall grind the U.I.M. registration number, and the manufacturer serial number into the cockpit/midsection of the boat.

Cockpit structure must include securely attached flotation capable of floating the cockpit, driver, motor and any attached structure.

The National Authority of the manufacturer of the reinforced cockpit will receive an acknowledgement from the U.I.M. office.

In the case of series manufactured cockpits, the letter will refer to the cockpit manufacturer and type.

## 509.02 - PICKLE-FORKS

A boat is allowed to race in a re-started heat/race without a deformable pickle-fork, only if it has been lost during the stopped heat/race.

All catamaran type boats must comply with the following : The main body of the sponson must end in a minimum 100 sq.cm forward bulkhead made of a minimum 8 mm thick plywood or equivalent material. This bulkhead must be an integral part of the main structure of the sponson and must have a rounded area of at least 10 cm length. See following sketch A.

The following will apply to outboard classes above 1500 cc, all other cockpit classes and any boat equipped with deformable pickle-forks.

Race boats of catamaran type, designed and equipped with pickle-forks, must have deformable and energy absorbing pickle-forks according to the following:

“The most forward end of the picklefork must be deformable and must be designed to crush.

“The deformation must start at a maximum of 100 kg.

“The pickle fork must :

- be detachable and have nothing inside
  - have a front end of minimum horizontal radius of 35 mm
  - have of front end minimum radius of 20 mm in all other directions
- “According to the following drawings”

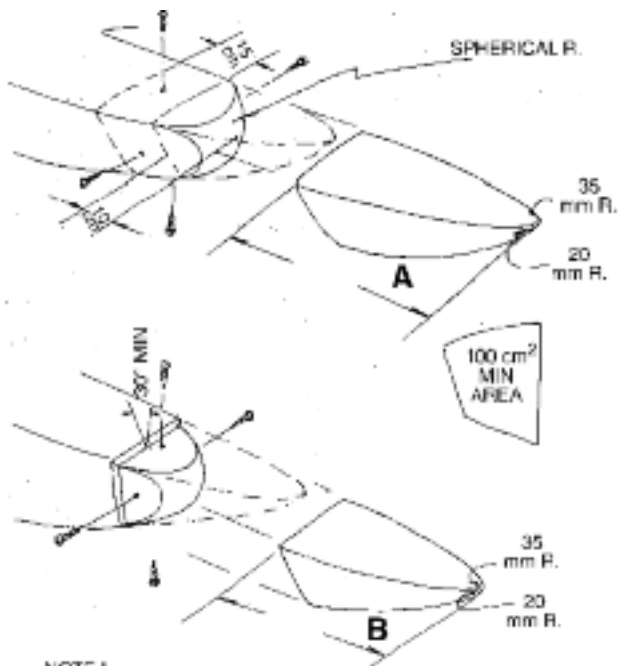

NOTE 1

PICKLEFORK MUST DEFORM AT 100 kg MAXIMUM

FOR ALL FORMULA BOATS  
EXCEPT F-500 DIMENSION  
A=50cm B=35cm  
THESE ARE MINIMUM  
DIMENSIONS.

FOR ALL OTHER PICKLEFORK BOATS  
A=40cm B=25cm  
THESE ARE MINIMUM  
DIMENSIONS.

The nose of the cockpit of boats built after January 1, 2001 must have the same minimum dimensions as the front of the sponsons before the collapsible picklefork.

If a collapsible front is used on the cockpit, it must have the same minimum dimensions as the picklefork.

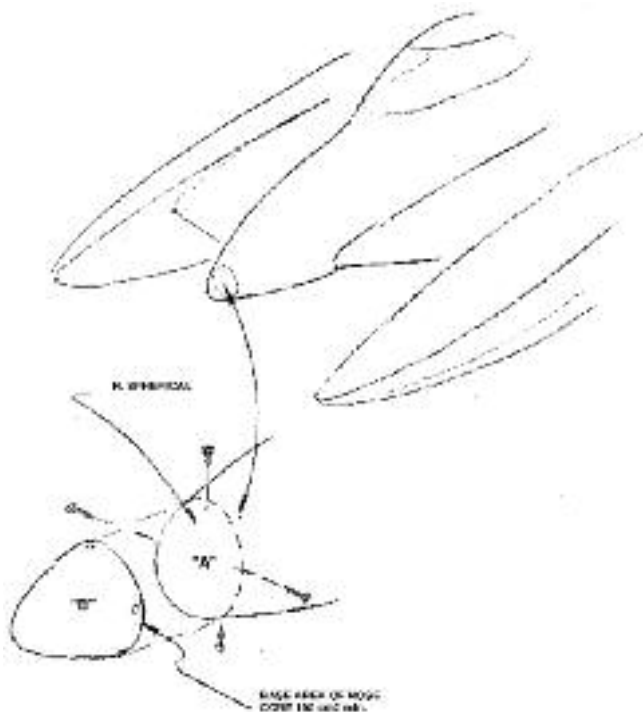

- A. The front of cockpit must have the minimum radius as the front of the main body of the sponson, before the crushable picklefork.
- B. A deformable nose may be added to the cockpit but it must be detachable, have nothing inside, have the same minimum dimensions as the detachable picklefork and deformation must start at a maximum of 100 kg.

### **509.03**

Any competitor driving in an approved reinforced cockpit design boat will be in a restraint system consisting of a minimum 5 strap/4 point mounting design.

Not closing the belt in cockpit classes will result in a suspension for the 2 following races of the Series and for titled Championships run in one round, in a suspension at the next Championship.

Strap locations will be minimum two each hip, crotch, two-shoulder, all hooked together in a central release system. This release mechanism must remain released/open once it is activated and until it is reset. A high strength, highly visible, lanyard will be attached to the release lever of the lever/latch system. Belting shall be a minimum of 5 cm (2 in) width.

The driver harness attachments bolts in reinforced cockpits must consist of a minimum of 8 mm bolts, 1.25 thread, grade A4 and 3 mm stainless steel plate of 100 sq.cm per attachment point. There must be a spacer and a washer on the attaching bolt. The spacer must be glued into the cockpit.

It is mandatory for boats that the shoulder harness straps should be mounted to a metal channel spanning the backboard securely fastened to the sides of the centre section of the boat as shown in 509.18.

Boats manufactured starting from January 1<sup>st</sup>, 1997 will have to be provided with reinforced cockpit having the following minimal measures:

It is taken into account the need to leave around the body the volume necessary to absorb some slight deformation without remaining trapped into the cockpit:

- The length between the back rest and the base of the feet must be cm. 126 or more
- The height between the base and the roof of the cockpit for the race boat furnished with closed cockpit and seat shall be such that the minimum head clearance of 509.05 is maintained. The driver shall not be reclined more than 45 ° from the vertical.
- The width at the level feet must be cm. 28 for a cockpit with only two pedals or no pedals. If three pedals are required the minimal width must be cm. 36
- At knee level the width must not be less than cm. 40
- At hip level the width must be cm. 48 or more
- The vertical internal dimension at foot level must be cm. 33 or more
- The vertical internal height at knee level must be, in order to obtain an easily extraction of the pilot in case of accident, at least cm. 45
- The length of the opening in the cockpit for boats built after 1<sup>st</sup> January 2006 must not be inferior to cm. 65, and, a minimum width at some point, of 46 cm in order not to represent an obstacle to the extraction of the pilot
- The width at shoulder level, not less than cm. 56 from the lower point of the cockpit, must be cm. 48

If a homologated “integrated canopy structure” is used then the canopy must be fitted, closed and latched at all times while engaged in practice or racing.

## **509.04**

A jacket with ballistic covering of orange colour having approximately 4.5 kg (10 lbs) flotation and equipped with epaulette type extraction loops on the shoulders and properly fitted to prevent being accidentally pulled over the head is mandatory.

Flotation overalls are a permitted alternative to life jackets, but must conform to all life jacket requirements (colour, buoyancy, protective plates, collar, etc.). The overalls must also include the cut resistant material required in rule 205.11.

### **509.05**

Minimum 5 cm (2 in) clearance above driver's head (with 10 cm (4 in) recommended), covering at least 50 % of the top of the helmet and at least 50 % of the side of the helmet with the driver's head in the furthest aft position, as an integral part of the cockpit construction.

For new boats built after January 1<sup>st</sup> 2006, the cockpit should afford a minimum 5 cm (2in) clearance above the drivers head (with 10 cm - 4 in - recommended) and cover 50 %, +- 5 % of the top of the helmet and 50 % +- 5 % of the side of the helmet with the driver's head in the furthest aft position, as an integral part of the cockpit construction.

It is highly recommended at present and mandatory for new boats built after January 1<sup>st</sup> 2009, the cockpit must afford a minimum of 10 cm (4in) clearance above the drivers head and extending laterally at least 45° from the vertical.

For integral load bearing canopies the canopy structures will provide the helmet coverage. The integral load bearing canopy structure will be at least as strong as the reinforced cockpit structure.

### **509.06**

Minimum 12 mm (1/2 in) 4 kg (9 lbs) Ethofoam or other energy absorbing foam support completely around the inside of helmet area to prevent injury from helmet hitting cockpit. Acceptable free space for helmet is approximately 5 cm.

### **509.07**

The top of the front of the cockpit will be a maximum of 10 cm (4 inch) below eye level, and so constructed as to deflect water away from the driver.



## 509.08

Energy absorbing foam padding is to be strategically placed inside the cockpit -limiting side-to-side head movement and areas where the knees, hands, etc., might impact.

In addition the Hans Device is highly recommended for F1 and is recommended for F2, S2000, S3000.

Seats are mandatory for F1/F2 cockpits and strongly recommended for all other cockpit classes.

### OBJECTIVE OF SEAT

Work with the restraint belts connecting driver's body securely to the cockpit, thus creating minimal movement between the cockpit and body.

Spreading of load over the body, reducing the chance of local loading and injury.

### SEAT

Construction to be stiff and strong enough so that attachment to cockpit is secure and movement between any part of the seat and cockpit is minimal (less than 10 mm) in crash loading.

Closely fitted to the rear and side of each driver's shoulders, ribcage, pelvis and thighs (to at least midway from hips to knees).

Minimal padding that is sufficient for driver comfort while racing (typically 10 mm).

### RECOMMENDED

Flat panels beside the legs, to reduce possible injury.

No exposed hardware, inside cockpit, which would come in contact with the driver, in a crash.

**509.09**

No sharp edges or protrusions anywhere inside or around the entryway of cockpit.

**509.10**

A removable steering wheel is mandatory.

The steering wheel must be easily removable without tools.

It is recommended that a centre pull ring type release (using only one hand) be used with detachable steering wheels.

**509.11**

Left and right rear-view mirrors are mandatory.

**509.12 - MOTOR SHUT OFF SWITCH**

All boats with reinforced cockpits will have an ignition shut- off switch for the motor, located on the left (port) outside of the cockpit. It will be clearly marked "MOTOR SHUT OFF SWITCH". Kill switch lanyard connections are not required on boats with reinforced cockpits.

Lanyard connection to the life vest is required to shut off the fuel on boats with electric fuel pumps.

**509.13 - VISIBILITY IN COCKPITS**

For boats built after 1<sup>st</sup> January 2006, the driver must have, when strapped in his cockpit, at least a free view of 180 degrees.

**509.14**

Air vents must be provided in the sponsons or into cockpit of all catamarans : 2 x 20 cm<sup>2</sup> (3in<sup>2</sup>).

For catamaran boats these air vents cannot be behind the driving position.

These air vents can be behind the driving position of V nosed boats and in the bow.

Airtight compartments in the aft end of racing boats are prohibited.

### **RECOMMENDED FOAM FLOTATION (see § 503.01) AND AIR VENTS LOCATION**

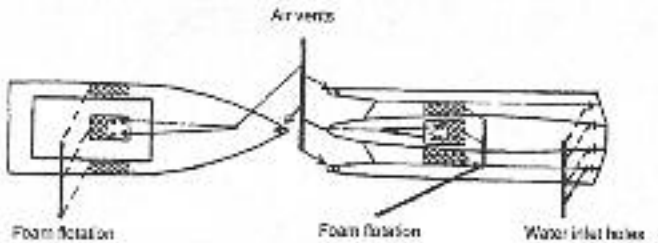

#### **509.15**

Water inlet holes on catamarans as shown in the sketch must be in the rear of the centre section fore and aft sides.

These holes must be at least 40 sq. cm (6 sq. in) in an area each side and communicate with air space inside the sponson. Any communicating holes in intervening bulkheads must be the same size. Air/water must be able to pass freely from these holes to air vents in the upper front of the sponson/boat.

#### **509.16**

All windscreens will be shatterproof material. All reinforced cockpit canopies shall have an external handle or hand hold opening to facilitate the opening of the canopy.

The following requirements are specified for reinforced cockpit canopies (For F1, mandatory for new construction after January 1, 2005. For S3000, F2 (S2000), mandatory for new construction after January 1, 2006:

1. Canopy windscreen/window material and shapes shall be a minimum of (8mm) polycarbonate material of high optical grade with scratch resistant outer coating. Such canopy shapes, forms, and materials are available, for example, from Formtech Plastics Inc., USA +1 800 860 7572. ***For F1 all the rules in 509.16 apply regardless when cockpit was built. It is also possible to use automotive safety glass with proper testing reports given to the U.I.M. for the canopy as long as it is stronger than the 8mm polycarbonate.***
2. All canopy support inner and outer frames, “U” and “H” channels, shall be constructed of a minimum of 2000 grams of “S” glass and/or Kevlar and bonded utilizing epoxy resin.
3. If the polycarbonate canopy frames are not glued, the frames shall be affixed thru-bolted utilizing bobbins/sleeves made of nylon, delrin, aluminium, or other material so as to not directly cause clamping forces to the polycarbonate material by thru-bolts. Bolt spacing shall be no greater than every 5 cm and shall incorporate the use of 6mm diameter (minimum) stainless steel bolts. All bolts shall utilize stainless steel nylock or acorn nuts with washers. No bolt threads or sharp edges shall endanger the driver in the interior of the cockpit.
4. All canopy hatches, lids, and caps shall be constructed of a minimum of 12 mm foam or balsa core material of 3 kg density laminated with 2000 grams of “S” glass and/or Kevlar bonded with epoxy resin.
5. It is recommended that All polycarbonate material should be able to withstand the loads consistent with a minimum of a 350 knot, 4 pound bird strike test as employed by Texstar Inc., USA, manufacturers of the F-16 canopy. Such tests may be specified by U.I.M. at a future point in time. International standard tests like DIN 52290 ; BS 5444 ; ISO 179. For impact strength and compliance.

6. All outer edges of canopies and hatches shall be protected from water intrusion leading to possible failure by the use of water deflectors, frames, or channels.
7. All canopy or hatch openings which allow access to the cockpit or driver shall include provision for a slot and pry bar pad to be utilized by rescue in the event of jamming or failure.
8. All canopy structures, hardware hinges, mechanisms, construction techniques and installation methods are subject to approval by the cockpit commission.
9. ***In F1 only***, for the purpose of the development of an integrated canopy structure, the U.I.M. cockpit Committee can determine that rules 509.06 and 509.07 do not apply ***and that the length of the opening in the cockpit may be less than 65 cm but must not be less than 55 cm***, under the condition that the manufacturer certifies in regard of the canopy:

The sufficient strength of the construction and at a minimum equal strength and integrity to existing cockpit/canopy systems.

That the canopy passed all tests foreseen in this rulebook.

The driver of such cockpit must declare in writing, that he is aware to drive such experimental cockpit under this rule. Such construction may race for a maximum period of 2 years without further homologation in the rulebook.

This permission can be withdrawn by the U.I.M. cockpit Committee for safety reasons.

10. All hinges attached to a reinforced cockpit canopy must have pins easily pulled out, and utilise pull rings or knobs, accessible both externally (for diver) and by the driver below the closed canopy.

Mandatory for F1, S3000, F2 and S2000.

The following minimum specification is required for canopy hinges:

- a. The canopy safety hinge shall be manufactured of stainless steel.

- b. The minimum length of the hinge shall be 10 cm overall.
  - c. The minimum width of the hinge shall be 3 cm.
  - d. The minimum thickness at the mounting surface shall be 3 mm with 3 fasteners at the end.
  - e. The pivot point shall be a fixed 6mm diameter axle pin and shall not be a quick release point of the hinge.
  - f. A secondary quick release pin of the push/pull type with a minimum 6 mm diameter shall be incorporated in such a manner as to enable the hinge to be easily released by rescue personnel.
  - g. The secondary push/pull shall include a drive out pin feature, as well as a stainless steel pull ring.
  - h. The design of the hinge shall prevent the binding of the quick release pin in the event of an incident requiring its removal.
11. Canopy latches or closers must be designed to keep the canopy closed during an accident.

## 509.17

It is recommended that in a reinforced cockpit there is an opening of 60 sq. cm (9 sq. in) above the helmet so as to reduce the hydraulic effect on the driver in case of an accident.

For old and new cockpits the reinforced cockpit backboard behind the driver shall be at a minimum the same strength as the sides of the reinforced cockpit. The lay up schedule and bonding mechanism shall be defined in the reinforced cockpit registration questionnaire.

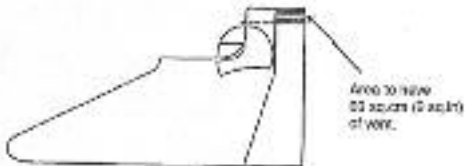

## 509.18

These are the mandatory requirements for the placing of seat belts and shoulder harness to be used in a reinforced cockpit: Any substitution system must be approved by Safety Cockpit Committee.

The crotch strap must be anchored to the capsule bottom with a minimum 10mm diameter bolt and locking nut. A 10cm diameter or, 10cm square with radiused edges and corners washer or plate with a thickness of 5mm aluminium or 3mm steel will be used between the outside of the bottom of the cockpit and the bolt. Bushings will be used to prevent crushing of the cockpit.

As an alternative the crotch strap may pass through a structure of 1.5x equivalent strength on the bottom of the cockpit just in front of the seat to prevent sliding forward or upward.

### ALTERNATIVE CROTCH STRAP ANCHOR

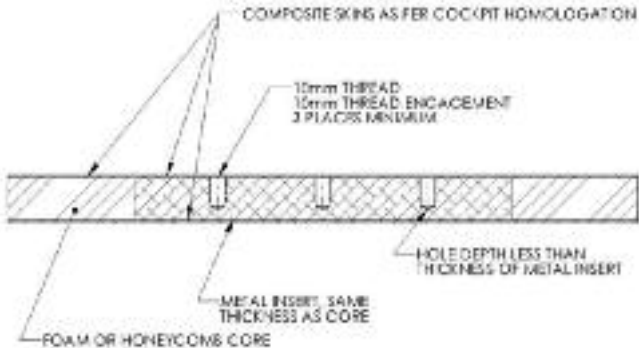

Shoulder harness should be installed 90° to spine at shoulder line to minimize compression injuries under high "G" loading.

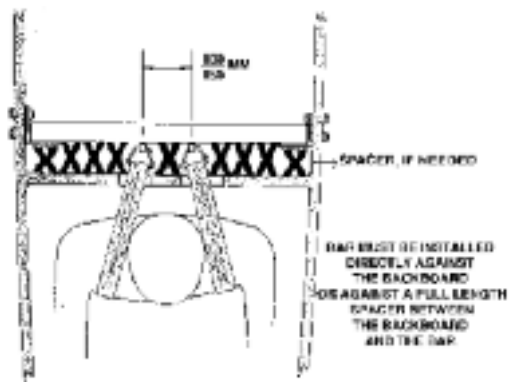
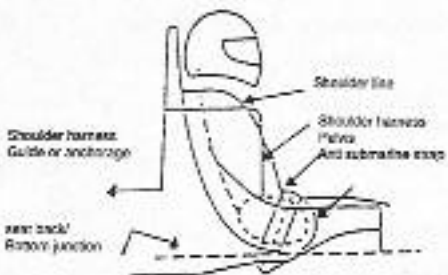



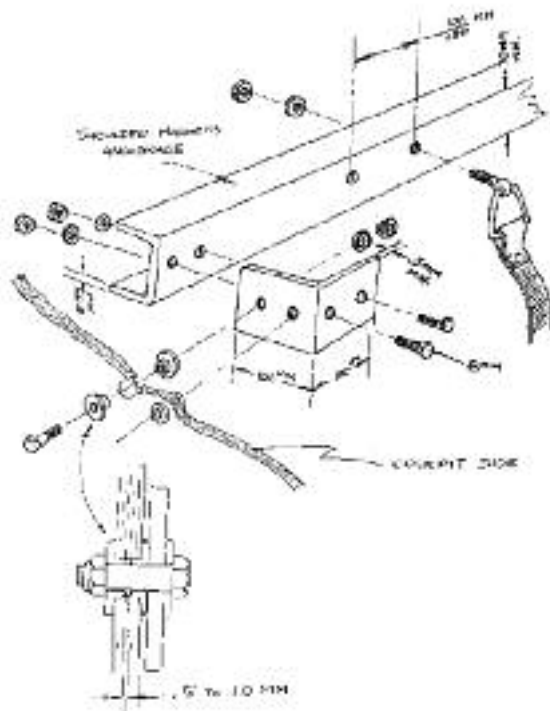

## ALTERNATIVE SHOULDER HARNESS ANCHORAGE FOR BOATS WITH CRASH BOXES

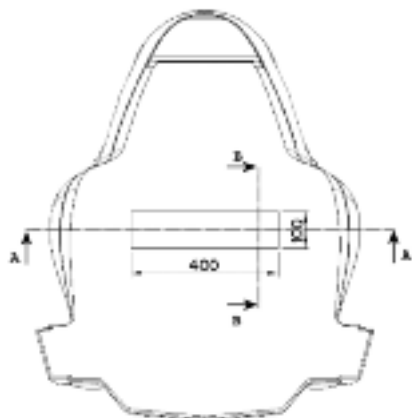

BACK VIEW OF THE SEAT-BACK BULKHEAD

SECTION A-A

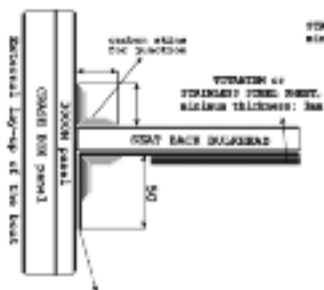

Additional minimum 1.00 mm  
Carbonfiber skin

SECTION B-B

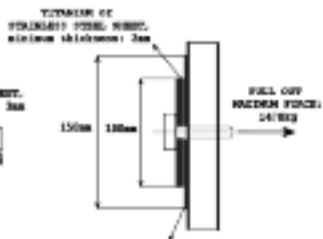

Additional minimum 1.00 mm  
Carbonfiber skin

## 509.19

To assist rescue crews, cockpit boats must have the bottom of that part of the cockpit containing the driver or all materials covering the bottom of the cockpit painted international orange and labelled in the centre with 30 cm (12 in) letters for the boat number, and 10 cm (4 inch) letters specifying other critical information such as: breathing apparatus (BrA), head restrain (HsD), etc. With breathing apparatus means only breathing equipment that automatically serve an unconscious driver with breathing air. Not the “spare air” type that must be handled by the submerged driver.

### GUIDELINES FOR INSPECTION OF REINFORCED COCKPITS.

- Check manufacturers ID plate and registration number.
- Check buoyancy behind bulkhead.
- Check seatbelts for wear, attachment points and release systems. (Check for corrosion, lack of maintenance, lubricated release system etc.)
- Check removable steering wheel systems. (Lack of maintenance, lubrication etc.)
- Have the driver to put on all safety equipment and get into the cockpit. Fasten all seatbelts, put steering wheel on, cover drivers visor and check to see that the driver can release him/herself.
- Check that the driver fits inside the cockpit as described in §509.05.
- Check water deflector as in §509.07 on cockpit top front.
- Check for sharp edges and energy absorbing foam inside cockpit.
- Check left and right rear view mirrors.
- Check air vents. As in §509.14
- Check water inlet holes in back of boat centre section
- Check bottom of cockpit for orange colour and boat number.
- Check function and position of MOTOR SHUT OFF SWITCH.

These guidelines are only as a help to the scrutineers of reinforced cockpits.

## **509.20 - AIR SUPPLY**

The driver must have air available as either “Spare air” or air which is supplied continuously to the driver.

The air bottle is to be fully charged prior to the time trials and racing. This air supply bottle may be carried on the driver or securely mounted in the boat. It is the responsibility of the driver to have a fully charged bottle prior to the time trials or race. The regulator shall work in any position.

## **510 - RACING INBOARDS (R)**

### **511 - CLASSES**

R 1000 cylinder capacity of the motor up to 1000 cc incl.

R 1500 cylinder capacity of the motor from 1001 to 1500 cc incl.

R 2000 cylinder capacity of the motor from 1501 to 2000 cc incl.

R 2500 cylinder capacity of the motor from 2001 to 2500 cc incl.

R 5000 cylinder capacity of the motor from 2501 to 5000 cc incl.

R 7000 cylinder capacity of the motor from 5001 to 7000 cc incl.

R  $\infty$  cylinder capacity of the motor from 7001 to infinity

### **512 - HULL**

#### **512.01**

The hull design is free.

## 512.02

Any device to produce a sudden braking effect, causing excessive water spray reducing visibility, is forbidden.

## 512.03 - MINIMUM DIMENSIONS

Class	Weight	Length	Reinforced cockpit
R 1000	300 kg	4.20 m	mandatory
R 1500	350 kg	4.50 m	mandatory
R 2000	390 kg	4.80 m	mandatory
R 2500	420 kg	5.10 m	mandatory
R 5000	600 kg	5.70 m	mandatory
R 7000	700 kg	6.10 m	mandatory
R $\infty$	800 kg	7.00 m	mandatory

- 1) The minimum weights mentioned above are the weight of a complete rig weighed directly after the race without driver, or residual water but including the residual fuel.
- 2) Measurements are taken while the boat is ashore.

The length must be measured as the overall length of the hull between perpendiculars at the foremost and aft most rigid part of the hull.

Any extending parts, rubbing stanches, fenders, stabilising and trim tabs and rudder are not to be included.

## 513 - MACHINERY

### 513.01

The motor is free.

The motor must be fixed inside the hull.

The power transmission train must pass through the structure of the hull.

All modifications are allowed.

### **513.02**

Only one propulsion device is allowed and the total effort must be applied to the water.

### **513.03**

When the propulsion is of the water jet type, the jet may be ejected in the air.

### **513.04**

An electric starter and battery must be on board.

### **513.05**

The transmission is free.

## **514 - FUEL**

See 508.01, 508.03, 508.06, 508.07, 508.08, 508.09, 508.10, 508.11.

## **515 - RACING INBOARD - HISTORIC (H.R.) - FORMULA R 1000**

## **516 - CLASSES**

Formula R 1000 cylinder capacity of the motor up to 1000cc incl. (for old Wartburg engines max capacity is 1020 cc).

Minimum weight hull only 200 kg.

Minimum weight with driver 280 kg.

HR 2000 Cylinder capacity from 1001 cc. to 2000 cc. included.

Cockpits are required for the HR 2000 only.

## **517 - HULL**

### **517.01**

The hull must be of a hydro type (the sponson should not exceed 60% of the total length of the hull).

Pickle forks: as per 509.02.

Either a reinforced cockpit or side protection as per rule 522.02, even if the driver is in a sitting position. If in a sitting position the reinforcing must extend up to approximately the driver's shoulder height and forward to approximately the driver's feet.

### **517.02**

Any device to produce a sudden braking effect, causing excessive water spray reducing visibility, is forbidden.

## **518 - MACHINERY**

### **518.01**

Only naturally aspirated, reciprocating, carburetted boat, motorcycle or motor car engines, of a model and type manufactured at least ten years ago, are permitted.

***Also engines which are originally manufactured with fuel injection are allowed provided they are re-worked to use carburettors only.***

It will be the responsibility of the driver to prove the eligibility of the engine.

The drive line between engine and propeller to be basically straight (no Z drives). A gearbox may be attached at the motor however it is forbidden to change the gears while racing.

### **518.02**

For HR 2000 cc. only automobile motors built before 1987 are allowed.

## **519 - FUEL**

See 508.01, 508.03, 508.06, 508.07, 508.08, 508.09, 508.10, 508.11.

## **520 - RACING OUTBOARDS (O)**

### **521 - CLASSES**

- O 125      cylinder capacity up to 128 ccs.
- O 175      cylinder capacity up to 175 ccs incl.
- O 250      cylinder capacity up to 250 ccs incl.



- 350 cylinder capacity up to 350 ccs incl.
- 500 cylinder capacity up to 500 ccs incl.
- 700 cylinder capacity up to 700 ccs incl.
- 850 cylinder capacity from 701 up to 850 ccs incl.
- 1000 cylinder capacity of the motor from 851 up to 1000 cc incl.
- 1500 cylinder capacity of the motor from 1001 up to 1500 cc incl.
- 2000 cylinder capacity of the motor from 1501 up to 2000 cc incl.
- 3000 cylinder capacity of the motor from 2001 up to 3000 cc incl.
- $\infty$  cylinder capacity of the motor from 3001 cc to infinity.

***In order to compete experimentally in O125 class, four stroke engines will be allowed 100% (double capacity) greater cylinder capacity. Single cylinder, gasoline fueled, atmospheric induction engines are allowed only.***

## **522 - HULL**

### **522.01**

For O 125, O 175, O 250 and O 350 the hull must be only of Hydroplane type with a maximum sponson length of 60 % of the total length of the hull (driver in kneeling or prone position only).

Any longitudinal air entrapment structures on either side of the hull behind the sponsons must be less than 40 mm deep at the transom. They must not extend beyond a straight line drawn from the rear lower point of the transom and the point 40 mm below the bottom of the transom (measured from a straight line across the boat at the transom as shown on the sketches).

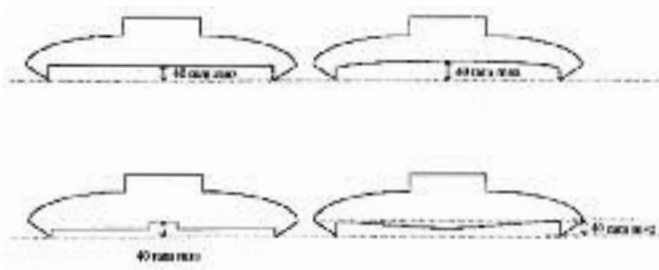

For the classes O 500 to O  $\infty$ , the hull design is free.

## 522.02

All hydroplane hulls in classes O 125, O 175, O 250, O 350, OSY 400 must have reinforced side protection as shown in the sketches.

All dimensions are minimum unless stated. Measurements taken from inside of hull from solid floor on which the driver lays or kneels (no cushions). Reduction to the front side panel is permitted for vision or to have vision panel installed.

On kneelers the amount of cut out to keep stabilisation is as per drawings and no reduction at front.

Cockpit coaming sides shall be made of wood/Kevlar, wood/Kevlar/carbon, or alternatively, carbon/Kevlar/foam core/glass composition. The Kevlar composition layers add up to a minimum of 340 gm. (10 oz.). The Kevlar (and carbon, if used) shall be sandwiched between two or more layers of marine plywood and provide a minimum thickness of 9 mm. All composite coaming construction shall have a minimum of 9 mm thickness. An inspection area shall be provided in the cockpit side in order to determine that the required materials have been used. It is recommended that this area be a set of concentric circles starting with an approximately 25 mm. diameter and reducing in diameter as each layer of the construction lay-up is exposed.

For retrofit of existing boats, reinforcement shall be 2 layers of a minimum of 315 grm Kevlar material to total 6 mm minimum thickness. This should be bonded to clean wood, free of varnish, paint, etc. Alternatively, a panel fabricated as described in the paragraph above, meeting the dimensional requirements, may be bonded to the interior surface of the existing cockpit sides to provide reinforcement.

All hydroplane hulls with pickle forks must have sponson leading edges of a blunt surface that is a minimum of 25 mm radius in one direction. Minimum thicknesses are as shown in the drawing. If extensions of the pickle forks are used, it must have deformable pickle forks for a minimum length to give an exposed blunt surface when removed that is a minimum of 25 mm radius in one direction.

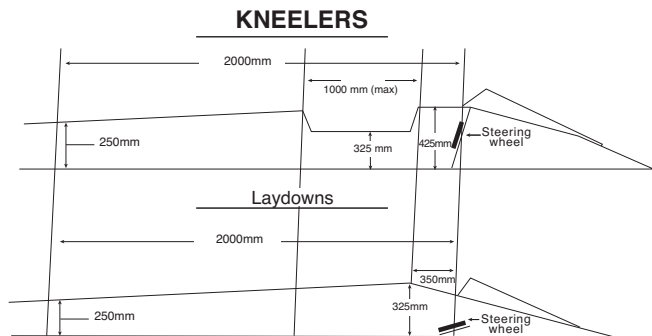

All Dimensions  
Minimum unless noted

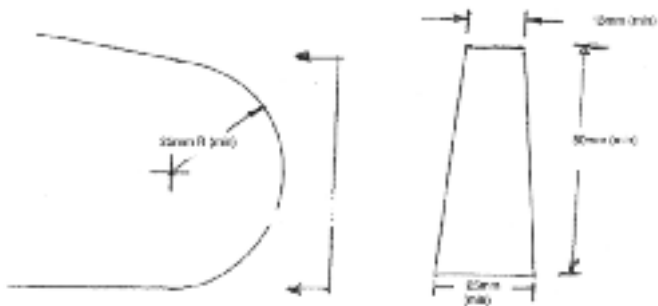
**SPONSON TIPS**

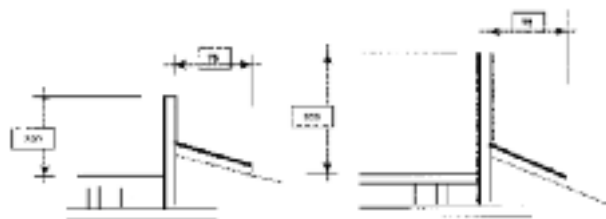

Section B

Section A

2 layers  
37 Agasa  
Aramid fibre or  
comparable

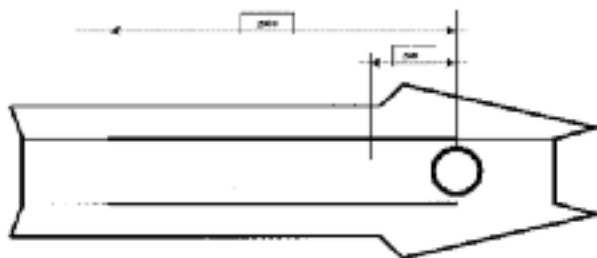
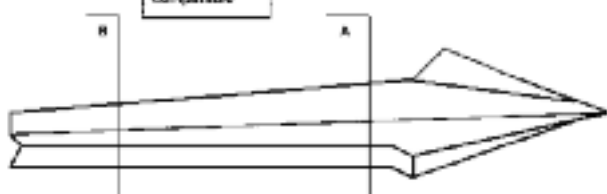

## 522.03

Any device to produce a sudden braking effect, causing excessive water spray, reducing visibility, is prohibited.

## 522.04 - MINIMUM DIMENSIONS

Class	Minimum Weight without driver	Minimum Weight with driver	Reinforced cockpit
O 125	<b>100 kg</b>	170 kg	
<b>O 175</b>	<b>110 kg</b>	<b>180 kg</b>	
O 250	120 kg	190 kg	
O 350	130 kg	210 kg	
O 500	180 kg	260 kg	mandatory
O 700	180 kg	260 kg	mandatory
Class	Weight	Length	Reinforced cockpit
O 850	250 kg	3.90 m	mandatory
O 1000	300 kg	4.20 m	mandatory
O 1500	350 kg	4.50 m	mandatory
O 2000	390 kg	4.80 m	mandatory
O 3000	450 kg	5.10 m	mandatory
O ∞	520 kg	5.30 m	mandatory

- 1) The minimum weights mentioned here above are the weight of a complete rig weighed directly after the race without residual water but with residual fuel.
- 2) Measurements are taken while the boat is ashore.

The length must be measured as the overall length of the hull between perpendiculars at the foremost and aftmost part of the hull including deformable pickle-forks if so designed and equipped.

Any extending parts, rubbing starches, fenders, stabilising and trim tabs and rudder are not to be included.

## **523 - MACHINERY**

### **523.01**

The motor is free except Class O 125 which is restricted to single cylinder only.

An outboard motor is a mechanical propulsion assembly which can be removed from the boat as a single unit, complete with its transmission, and which does not transmit the power through the hull at any point. Any mechanism intended to modify the angle of attachment and/or the height of the motor is authorised.

The motor thus taken off and placed ashore must be capable of being started, fed by its fuel tank.

The mounting supports fixed to the boat, the control levers, the tachometer with its connections, the battery with its conductors and the fuel tank and fuel lines do not form part of the power unit.

### **523.02**

Only one propulsion device is allowed and the total effort must be applied to the water.

### **523.03**

When the propulsion is of the water jet type, the jet may be ejected in the air.

### **523.04**

The transmission is free.

**523.05**

All un encased outboard motors with capacitor discharged ignition shall have a flywheel guard.

**524 - FUEL**

See 508.05, 508.06.

*Four stroke "O" class engines only : see 508.01 - 508.02 - 508.06 - 508.08 - 508.09 - 508.10 - 508.11.*

**525 - CLASS OSY 400****527 - HULL****527.01**

The hull must be of a hydro type (the sponson must not exceed 60 % of the total length of the hull).

Minimum weight with driver 180 kg.

**527.03**

A reserve of visible and sufficient flotation must be provided to keep the hull floating in case of accident (see § 503.01).

**527.05**

Any device to produce a sudden braking effect, causing excessive water spray, reducing visibility, is prohibited.



## **528 - MACHINERY**

Any machinery aimed at modifying the motor attachment angle and/or the height of the motor while the motor is running is forbidden.

### **528.01**

The motor must be a Yamato model 102, 202 or 302 series duly homologated by U.I.M.

### **528.10 - SOLE MODIFICATIONS ALLOWED**

- 1) It is permissible to use any ignition wire, spark plugs, propeller nut.
- 2) It is permissible to drill water drain holes in the ignition castings (coil plates and crankcase end cap) and these holes may be tapped and plugged.
- 3) It is permissible to use any fuel line or fittings providing threads in tank and carburettor are not changed. A fuel filter may also be used.
- 4) It is permissible to enlarge the gas tank by cutting it apart at the seam and adding at least 2" band (2" will give one third of a gallon more) or may build a complete tank, but it must be mounted the same as the original. The tank mount plate may not be modified.
- 5) A fuel pipe may be used for marathon racing but the hole in the crankcase must be plugged when racing same motor in closed course.
- 6) Bolt threads may be repaired by tapping oversize or use of helicoils.
- 7) Broken parts may be repaired by welding or use of plastic compound, if all contours remain the same. In addition to that, in the area of the crank shaft journals, where the crank shaft assembly is bedded a repair is permissible according to the following procedure. The crankshaft journal must be machined in that area to a smaller diameter. A steel bushing can be pressed onto the machined crankshaft journal. This steel bushing must have exactly the same contour as the material which is replaced by the bushing (outer

diameter, length). This repair assumes, that no changes to the weight and to the contour of the crankshaft assembly can be made.

- 8) Any water flow restrictions are permitted.
- 9) No polishing or removal of metal on any internal passages or carburettor, intake manifold, or tuned exhaust system.
- 10) No polishing or balancing of reciprocating or rotating parts.
- 11) Any type of thrust bracket adjustment is allowed providing no alterations are made to the motor and may not be adjustable while boat is moving.
- 12) The tilt lock lever may be removed and the spacer on the tilt bracket bolt.
- 13) The holes in steering bar may be drilled larger for attaching steering cable.
- 14) Any device may be used to hold spark lever in advance position.
- 15) Spray shield may be modified to use throttle cable, and for choking carburettor.

Where a hole is in the side it must not exceed 30 mm in diameter or equivalent area.

- 16) The propeller shaft may be turned down or replaced to fit any propeller.

The propeller is free

- 17) The use of non-Yamato parts are forbidden.
- 18) Measurements not quoted in the homologation sheet may not be altered. If a detail cannot be verified with the aid of the pictures in the homologation sheet, the part in question can be compared to corresponding stock part. In such a comparison it is only possible approximately to use the comparable measurements as the manufacturing tolerances are not available.

- 19) The driver is responsible for the condition of the engine as raced. Errors on the part of one manufacturer, mechanic or previous owner is no excuse.
- 20) Shorting switch is mandatory (i.e. jack plug).
- 21) Oversize pistons allowed to first over-bore only (max.bore size: 2.622 or 66.59 mm e.g. 66.50 + 0.09 mm) When ports in cylinders are adjusted to the dimensions specified in the homologation sheet, material may only be removed in the specified opening to a depth of 10 mm, to match the shape of the original adjacent connecting passage (channel) outside the adjusted port opening. This also applies to other openings in the motor for which the dimensions are specified in the homologation sheet.
- 22) Any type, size or make of nut, bolt, screw, washer may be used except for butterfly screw which must be standard.
- 23) Painting - it is permissible to paint any part of engine and accessories any colour.
- 24) Any holes can be drilled to safely attach engine to the hull.
- 25) A part from the above provisions, it is absolutely forbidden to make any alterations to the engine manufacturers standard components either by removal or addition of material. In particular this includes components being subjected to any form of machining, grinding, hand tooling, reworking, reshaping, fettling, polishing etc. unless it is specifically permitted.
- 26) Plug caps may be changed.

## **529 - FUEL**

See 508.01, 508.02, 508.06, 508.07, 508.08, 508.09, 508.10, 508.11.

## **530 - SPORT INBOARDS (E)**

## **531 - CLASSES**

E 1000 cylinder capacity of the motor to 1000 cc incl.

E 1500 cylinder capacity of the motor from 1001 to 1500 cc incl.

E 2000 cylinder capacity of the motor from 1501 to 2000 cc incl.

E 2500 cylinder capacity of the motor from 2001 to 2500 cc incl.

E 5000 cylinder capacity of the motor from 2501 to 5000 cc incl.

E 7000 cylinder capacity of the motor from 5001 to 7000 cc incl.

E  $\infty$  cylinder capacity of the motor from 7001 to infinity

## **532 - HULL**

### **532.01**

The hull design is free.

### **532.02**

Any appendage intended to lift the boat by an aerodynamic effect is prohibited. Hydrofoils are not allowed.

### **532.03**

Aboard inboard craft, the motors must be housed in a covered compartment or situated under the deck but adequately and efficiently ventilated.

Transmission links and all moving parts liable to cause injury or accident must be efficiently guarded.

## 532.04

Any device to produce a sudden braking effect, causing excessive water spray, reducing visibility, is prohibited.

## 532.12 - MINIMUM DIMENSIONS

Class	Weight	Length	Reinforced cockpit
E 1000	300 kg	4.20 m	mandatory
E 1500	350 kg	4.50 m	mandatory
E 2000	390 kg	4.80 m	mandatory
E 2500	420 kg	5.10 m	mandatory
E 5000	600 kg	5.70 m	mandatory
E 7000	700 kg	6.10 m	mandatory
E $\infty$	800 kg	7.00 m	mandatory

1. The minimum weights mentioned here above are the weight of a complete rig weighed directly after the race without driver, or residual water but with residual fuel.
2. For all series mentioned above:

Measurements are taken while the boat is ashore.

The length must be measured as the overall length of the hull between perpendiculars at the foremost and aftmost part of the hull including deformable pickle-forks.

Any extending parts, rubbing starches, fenders, stabilising and trim tabs and rudder are not to be included.

## 533 - MACHINERY

### 533.01

The motor must be fixed inside the hull.

The power transmission train must pass through the structure of the hull.

### **533.02**

Marine motors homologated by U.I.M. as having been built in series, that is with all identical and interchangeable parts and fitted ready for running, with a minimum number of 30 motors produced.

### **533.03**

The marine inboard motor is a mechanical assembly producing power, specially designed and manufactured for the propulsion of boats and which is catalogued and sold by an industrial firm.

### **533.04**

The motor must be ready to function, and must include the following items:

- all the accessories required for the functioning and regulation of the cooling system,
- an oil cooler,
- the motor installation mounts,
- the starting device and a generator for recharging the battery.

### **533.05**

The gear box and the exhaust manifold do not form a part of the motor.

### **533.06**

Only one propulsion device is allowed and the total effort must be applied to the water.

### **533.07**

Only automobile motors homologated by the Federation Internationale de Sport Automobile as laid out in the general list of FISA homologated cars in group N + A are allowed.

Group N: Production cars

Group A: Touring cars

### **533.08**

No other automobile motors homologated by the F.I.A. are allowed for powerboating.

### **533.09**

The alterations allowed by F.I.S.A are not allowed in motor boating. Only the alterations listed in Article hereunder are allowed.

### **533.10 - SOLE MODIFICATIONS ALLOWED**

1. The replacement of the dynamo by an alternator is allowed provided that the securing points of the replacing accessory and its driving system remain unchanged.
2. The fitting of a transistorised ignition system is allowed, provided that no mechanical part of the motor is altered.
3. For U.I.M. or F.I.S.A homologated motors reboring is allowed provided the total cylinder capacity does not exceed the limits that have been provided for the class in which the motor has been homologated.
4. The air filter can be taken out or altered.
5. Dynamic air intakes can be fitted to the carburettors.

6. The mechanically operated fuel pump may be exchanged with an electrically operated fuel pump, without obligation to keep the original location.
7. An oil filter and/or a radiator may be added when not provided by the manufacturer. The original(s) may be changed.
8. The carburettor(s) fitted by the manufacturer may be replaced by one or more carburettors or by a fuel injection system provided they can be fitted without altering the cylinder head.
9. The modification or replacement of the intake manifold is allowed.
10. The valve springs may be replaced by others from any origin, but without modification of the number fitted by the manufacturer and provided they can be fitted without any modification to the original brackets.
11. Pistons are free.
12. The camshaft(s) is (are) free.
13. Increasing the compression ratio by polishing the cylinder head (or using a thin gasket or the suppression of the latter) is allowed.
14. Any tuning operation such as polishing the original parts but not replacement of same, except for pistons, the springs and the cam shafts as specified above, are allowed.
15. In other words, provided it is always possible to establish indisputably the origin of a mass produced part, this component may be rectified, balanced, adjusted, its form reduced or changed by brightening, excluding any addition of material, any mechanical extension or any treatment modifying the characteristics of the molecular structure of the metal surface.

### **533.11 - ELECTRIC STARTER**

An electric starter and its battery are required on board, as well as a device for recharging the battery.



## **533.12 - TRANSMISSION**

Reverse gear is compulsory.

The transmission is free.

Going astern must be obtained by reversing the rotation of the transmissions which supply the propulsive effort. In waterjet propelled boats, the astern movement is obtained by diversion of the waterjet.

The control handle for reverse gear, ready for use, must be within hand reach of the driver. Astern manoeuvring of the boat must be possible by the action of reverse gear solely.

## **533.13**

Only one propulsion device is allowed and the total effort must be applied to the water.

## **534 - FUEL**

See 508.01, 508.02, 508.06, 508.07, 508.08, 508.09, 508.10, 508.11.

## **540 - SPORT OUTBOARDS (S)**

### **541 - CLASSES**

S	175	cylinder capacity of the motor to 175 cc incl.
S	250	cylinder capacity of the motor from 176 to 250 cc incl.
S	350	cylinder capacity of the motor from 251 to 350 cc incl.
S	550	cylinder capacity of the motor from 351 to 550 cc incl.
S	750	cylinder capacity of the motor from 551 to 750 cc incl.

S	850	cylinder capacity of the motor from 751 to 870 cc incl.
S	1000	cylinder capacity of the motor from 871 to 1000 cc incl.
S	1500	cylinder capacity of the motor from 1001 to 1500 cc incl.
S	2000	cylinder capacity of the motor from 1501 to 2000 cc incl.
S	3000	cylinder capacity of the motor from 2001 to 3000 cc incl.
S	∞	cylinder capacity of the motor from 3001 to infinity
F-4S	60 hp	
SL 90	90 hp	
SL 250	250 hp	

## 541.01 - LOW EMISSION ENGINES

In order to compete with parity in S.2000 class, low emission engines complying with 2006 EPA regulations will be allowed 30 % greater cylinder capacity (2600 cc). In addition, the effect of any air compressor used in support of and as part of the fuel injection system, shall be ignored in determining class displacement.

In order to compete with parity in S.3000 class, low emission engines complying with 2006 EPA regulations will be allowed 30 % greater cylinder capacity (3900 cc). In addition, the effect of any air compressor used in support of and as part of the fuel injection system, shall be ignored in determining class displacement.

For classes F-4S, SL 90 and SL 250, only engines conforming to EPA regulations are admissible.

## 541.02 - LOW EMISSION ENGINES

In order to compete experimentally in S.850 class, low emission engines complying to 2006 EPA regulations will be allowed **30%** greater cylinder capacity (**870 + 30 % = 1131 cc**). In addition, the effect of any air

compressor used in support of and as part of the fuel injection system, shall be ignored in determining class displacement.

## **542 - HULL**

### **542.01**

Only catamarans are permitted from class S 550 onwards.

### **542.02**

Any appendage intended to lift the boat by aerodynamic effect is prohibited. Hydrofoils are not allowed.

### **542.03**

In S2000, S3000, S infinity, SL 250 and endurance 2 + 3, the homologated delayed operation buoyancy airbag is mandatory for all boats with sponsons constructed of composites (foam construction sandwich).

### **542.05**

Any device to produce a sudden braking effect, causing excessive water spray, reducing visibility, is prohibited.

## **542.12 - MINIMUM DIMENSIONS**

Class	Weight	Length	Reinforced cockpit
S 550	260 kg	3.70 m	-----
S 750	280 kg	3.90 m	-----
S 850	330 kg	3.90 m	mandatory
S 1000	380 kg	4.20 m	mandatory

S 1500	430 kg	4.50 m	mandatory
S 2000	470 kg	4.80 m	mandatory
S 3000	530 kg	5.10 m	mandatory
S $\infty$	600 kg	5.30 m	mandatory
F-4S	350 kg	3.90 m	Yes
SL 90	400 kg	4.60 m	Yes (3000 N)
SL	525 kg	5.20 m	Yes (3000 N)

1. The minimum weights mentioned here above are the weight of a complete rig weighed directly after the race including driver, personal safety equipment, residual fuel but without residual water.
2. Measurements are taken while the boat is ashore.

The length must be measured as the overall length of the hull between perpendiculars at the foremost and aftmost rigid part of the hull including deformable pickle-forks if so designed and equipped.

Any extending parts, rubbing starches, fenders, stabilising and trim tabs and rudder are not to be included.

## **543 - MACHINERY**

### **543.01**

An outboard motor is a mechanical propulsion assembly which can be removed from the boat as a single unit, complete with its transmission, and which does not transmit the power through the hull at any point. Any mechanism intended to modify the angle of attachment and/or the height of the motor is authorised.

The motor thus taken off and placed ashore must be capable of being started, fed by its fuel tank.

The mounting supports fixed to the boat, the control levers, the tachometer with its connections, the battery with its conductors and the

fuel tank and fuel lines do not form part of the power unit. Only single motor is permitted.

## **543.02**

To be homologated as a sports motor, an outboard motor must be sold and advertised by an industrial firm as being manufactured in standard production series (that is to say with all parts interchangeable and with identical dimensions and materials with the equivalent part in another motor of the same model.) for the propulsion of boats.

To have homologation approved the numbers verified as in 505.01 must be:

up to 1000cc 1000 complete units

1001cc - 2000cc

- 500 units, 25 of which may be fitted with midsection, brackets and gearcases as in § 543.07.

2001cc and upwards

- 250 units, 25 of which may be fitted with midsection, brackets and gearcases as in § 543.07.

## **543.03**

A sports outboard motor must be able to run at a reduced speed.

## **543.04**

When the motor is in the water, the cooling must be effected by the homologated water circulation pump.

## **543.05**

An efficient gear changing system giving forward, neutral and astern movement is compulsory for motors up to and including 1000cc capacity.

The control handle for reverse gear, ready for use, must be within easy hand-reach of the driver when he is in the normal driving position. Manoeuvring of the boat astern must be possible by selecting reverse gear.

The casing of the underwater unit (gearcase) is free. All internal parts referred to on the homologation file must be maintained. Should the homologation provide for it, the exhaust will be a propeller exhaust.

### **543.06**

All lower unit exhaust openings must remain standard within the homologated size.

### **543.07**

For motors 1001cc capacity and above, forward, neutral and reverse gear are not compulsory. Such fixed gear versions are not necessarily intended for sale to or be used by general non-racing public. However, they must be available as an integral part of the complete outboard motor and homologated as such. The mounting brackets, midsection including exhaust pipes and gearcase, together with any parts required to fit these, must retain the dimensions specified on the homologation form.

### **543.08**

An electric or manual starter must assure a quick and easy start without external aids. It must be used as it was supplied by the manufacturer, no adjustment or alteration being allowed.

## **543.10 - SOLE MODIFICATIONS ALLOWED**

1. All studs, screws, nuts, bolts and their washers are free as well as the method of locking them;
2. The original propeller may be replaced by another. Gearcases with a propeller exhaust must use propellers equipped with an exhaust

tube of a diameter at least that of the machined recess into which the standard propeller boss fits at the rear of the gearcase. The length of this tube must be at least  $1/2(Q - P)$ , where Q and P are the dimensions shown on the sketch of the underwater unit on the homologation file;

3. The trim tab may be altered or removed to accommodate a propeller;
4. The cooling must be provided by the water pump;
5. Thermostats and pressure valves of the cooling system may be removed;
6. The steering mechanism may be altered. If the original steering bar is removed or new ones are installed, any openings created must be sealed to prevent the motor from pulling in additional air;
7. The swivel bracket may be altered for the purpose of installing a power trim and/or a power lift and the dampers (shock absorbers) may be altered or removed;
8. The rubber mounts of the motor may be altered, removed or replaced;
9. Revolution counters, water temperature gauges, water pressure gauges and similar instruments, can be installed;
10. Revolution limiters may be removed;
11. The gear interlock device on the starter may be removed;
12. Spark plugs are free;
13. Original carburettor jets may be replaced for another size;
14. Springs may be added to the throttle lever of the carburettors;
15. Re boring is allowed, but only piston assemblies supplied by the manufacturer of the motor may be used within the cc limit of the class. When ports in cylinders are adjusted to the dimensions specified in the homologation sheet, material may only be removed in the specified opening to a depth of 10 mm, to match the shape of the original adjacent connecting passage (channel) outside the

adjusted port opening. This also applies to other openings in the motor for which the dimensions are specified in the homologation sheet;

16. A part which is dimensioned in the homologation sheet may be machined for the purpose of reaching that specific measure;
17. A part may be machined to attain the weight quoted in the homologation sheet without altering other criteria given for the part in question. It is not allowed to change the flywheel but balancing machining is allowed if the dimensions and weights provided for on the homologation sheet are respected;
18. Measurements not quoted in the homologation sheet shall only be checked by visual comparison with standard parts. As the actual manufacturing tolerances are not published, small differences between the inspected part and the reference part must be accepted;
19. The fuel connector in the lower cover may be removed and the fuel hose from the fuel tank connected directly to the fuel pump. If this is done the opening left after the connector and around the fuel hose must be sealed to prevent extra air entering inside of cover;
20. Electric fuel pumps may be added provided the fuel still runs through the original fuel system and no parts are removed or blocked off;
21. No parts may be added to the motor unless specified in this rule;
22. It is allowed to extend the starter cord of a rewind starter so that the starting handle can be reached from the cockpit.

### **543.11 - MODIFICATIONS NOT PERMITTED ON LOW EMISSION ENGINES**

1. Blueprinting of the powerhead is not permitted, equivalent to F2/SST 120 classes.
2. Alteration or removal of any powerhead components is not permitted.
3. Electrical components and control system performance must remain standard



The following rules are NOT applicable to low emission engine:

543.10 Section: 5, 10, 13, 16, 17 and 20.

502.02 Section: 3 and 2, last sentence not valid (Only adjustments to meet dimensions in the homologation sheet are allowed).

## **544 - FUEL**

See 508.01, 508.02, 508.06, 508.07, 508.08, 508.09, 508.10, 508.11.

## **550 - MONOHULL OUTBOARDS (T)**

General: The purpose is to limit this class to simple monohulls easily built by an amateur or readily available commercially, each fitted with one single homologated “stock” motor, available on standard sale.

## **551 - CLASSES**

JT250 cylinder capacity of the motor to 265 cc incl.

T 250 cylinder capacity of the motor to 265 cc incl.

T 400 cylinder capacity of the motor from 251 cc to 400,5 cc incl.

T 550 cylinder capacity of the motor from 401 cc to 550 cc incl.

T 750 cylinder capacity of the motor from 551 cc to 750 cc incl.

T 850 cylinder capacity of the motor from 751 cc to 870 cc incl.

### **551.01 - LOW EMISSION ENGINES**

Class	hp	Weight	Length	Cockpit depth
GT15	15 hp	210 kg	3.10 m	0.35 m

GT30	30 hp	250 kg	3.50 m	0.40 m
GT60*	60 hp	350 kg	4.00 m	0.40 m
GT90*	90 hp	425 kg	4.50 m	0.40 m

\* plus powertrim as manufactured

Weight is including driver.

Engines :

Low emission engines complying with 2006 EPA Regulations will be allowed only. In GT60, GT90, integral powertrim is allowed (as manufactured).

The following modifications are expressly not permitted :

- No new openings are allowed for fitting steering bars etc.
- Alteration or modification of any powerhead components
- Removal of material from the powerhead for any reason other than recognised (by the manufacturer) repair
- ECU/PCMs equipped with race data memory, must not have the memory erased or modified without the prior permission of the technical inspector.
- Any information sourced by the technical inspector from the ECU/PCM's race data memory which does not correspond with the technical data declared by the manufacturer in the homologation file will be viewed as reason for disqualification.

### **MODIFICATION ALLOWED**

It is allowed to disable/remove the neutral switch and in gear starting protection wire.

The trim tab may be altered or removed to accommodate a propeller.

The rubber mounts of the engine may be replaced.

Power trim may be removed. The use of thrust block to adjust the trim angle is allowed.

Spark plug may be replaced with a non-modified standard spark plug with the same thread length.

Propeller nut is free.

## 552.01 - HULL

Only monohull form is permitted. The boat shall not present in any of its lines any configuration which could contribute to aerodynamic lift.

Transverse steps, tunnels, hydrofoils or devices which tend to add to the air pressure under the hull, are prohibited, except that protruding strips substantially parallel to the fore and aft line of the keel are permitted providing that in any channels, etc. so produced the horizontal measurements, of such openings with the boat on an even keel, do not add up to a total of more than 15 cm in any transverse section. Any divergence of such strips from a line parallel to the keel must show a minimum radius of 30 cm. If stopped short of the transom, strips must be tapered off to zero over a minimum length, viewed at 90 to the line of the keel and parallel to the surface of the hull in that area, of 15 cm. A single fixed vertical fin on the underwater body is allowed for directional stability. The maximum length of the fin is 250 mm.

## 552.05

Any device to produce a sudden braking effect, causing excessive water spray, reducing visibility, is prohibited.

## 552.12 - MINIMUM DIMENSIONS

Class	Weight	Length	Width	Boat depth
JT250	160 kg	3.10 m	1.25 m	0.35 m
T 250	180 kg	3.10 m	1.25 m	0.35 m
T 400	240 kg	3.50 m	1.30 m	0.35 m
T 550	265 kg	3.75 m	1.30 m	0.40 m
T 750	270 kg	4.00 m	1.35 m	0.40 m

T 850 boat only	250 kg	4.25 m	1.40 m	0.40 m
T850 boat+driver	330 kg			

1. The minimum weights mentioned here above are the weight of a complete rig weighed directly after the race including driver, personal safety equipment, residual fuel but without residual water
2. Measurements are taken while the boat is ashore.

The length must be measured as the overall length of the hull between perpendiculars at the foremost and aftmost rigid part of the hull.

Any extending parts, rubbing stanches, fenders, stabilising and trim tabs and rudder are not to be included.

The width of the boat is measured at the widest part of the hull.

## **553 - MACHINERY**

### **553.01**

An outboard motor is a mechanical propulsion assembly which can be removed from the boat in a single unit, complete with its transmission and which does not transmit its power through the hull at any point.

The motor thus removed and placed ashore must be capable of being started, fed by its fuel tank.

The mounting supports fixed to the boat, the control levers, the tachometer with its connections, the battery with its conductors and the fuel tank and fuel lines do not form part of the motor.

The attachment angle and the height of the motor must remain fixed while the boat is under way. But it is allowed to change the attachment angle between a heat and another.

The use of powertrim is allowed for monohull boats provided with safety reinforced cockpit, per rule 509.

For all T classes, the centre of the propeller shaft (measured at the centre point of the rear end of the propeller shaft) shall not be above the bottom of the boat measured at the lowest point of the bottom. No design of the hull, by fins, keels or convex shaped bottom to obtain a higher engine position is allowed. For boats with the power trim this height will be measured with the propeller shaft set parallel with the bottom of the boat.

This dimension will be checked in the “as raced” condition.

This dimension is affected by the attachment angle. In JT.250, T 250, T.400 and T. 550, it is not allowed to change the attachment angle by other means than pulling out and resetting tilt pin or by adjusting a thrust block on the outside of the transom for which adjustment tools must be required. It is only allowed to change the attachment angle when the boat is on land. After any change of the attachment angle the propeller shaft depth must be rechecked.

## **553.02**

To be homologated as stock motor, an outboard motor must be sold and advertised by an industrial firm as being manufactured in standard production series (that is to say with all parts interchangeable and with identical dimensions, weights and materials) for the propulsion of boats.

To be eligible for homologation, a minimum of 1000 units must have been built and assembled, certified by the manufacturer to the National Authority of the country of origin.

## **553.03**

The motor must be able to function at reduced speed.

## **553.04**

When the motor is in the water, the cooling must be effected by a water circulation pump.

The cooling water must circulate through the water pump and be fed only through the standard water intake, neither the position nor the shape of which may be modified.

### **553.05**

An efficient gear changing system giving forward, neutral and astern movement is compulsory.

The control handle for the reverse gear, ready for use, must be within easy hand reach of the driver, when he is in the normal driving position. Manoeuvring of the boat astern, must be possible by selecting reverse gear.

### **553.06**

An electric or manual starter must assure a quick and easy start without external aids. It must be used as it was supplied by the manufacturer, no adjustment or alteration being allowed.

## **553.10 - SOLE MODIFICATIONS ALLOWED**

Only the following modifications are allowed:

1. All studs, screws, nuts, bolts and their washers are free as well as the method of locking them.
2. The original propeller may be replaced by another but in classes T.750 and T.850 4 blades maximum. Gearcases with a propeller exhaust must use propellers equipped with an exhaust tube of a diameter at least that of the machined recess into which the standard propeller boss fits at the rear of the gearcase. The length of this tube must be at least  $\frac{1}{2}(Q - P)$ , where Q and P are the dimensions shown on the sketch of the underwater unit on the homologation file.
3. The trim tab may be altered or removed to accommodate a propeller, except in classes T.750 and T.850.
4. The cooling system must be provided by the water pump.

5. Thermostats and pressure valves of the cooling system may be removed.
6. The steering mechanism may be altered. If the original steering bar is removed or new ones are installed, any openings created must be sealed to prevent the motor from pulling in additional air.
7. The dampers (shock absorbers) may be altered or removed.
8. The rubber mounts of the motor may be altered, removed or replaced.
9. Revolution counters, water temperature gauges, water pressure gauges and similar instruments can be installed.
10. Revolution limiters may be removed.
11. The gear interlock device on the starter may be removed.
12. Spark plugs are free.
13. Original carburettor jets may be replaced for another size.
14. Springs may be added to the throttle lever of the carburettors.
15. Re-boring is allowed, but only piston assemblies supplied by the manufacturer of the motor may be used within the cc-limit of the class. When ports in cylinders are adjusted to the dimensions specified in the homologation sheet, material may only be removed in the specified opening to a depth of 10 mm, to match the shape of the original adjacent connecting passage (channel) outside the adjusted port opening. This also applies to other openings in the motor for which the dimensions are specified in the homologation sheet.
16. A part which is dimensioned in the homologation sheet may be machined for the purpose of reaching that specific measure;
17. A part may be machined to attain the weight quoted in the homologation sheet without altering other criteria given for the part in question. It is not allowed to change the flywheel but balancing machining is allowed if the dimensions and weights provided for on the homologation sheet are respected;

18. Measurements not quoted in the homologation sheet shall only be checked by visual comparison with standard parts. As the actual manufacturing tolerances are not published, small differences between the inspected part and the reference part must be accepted.
19. The fuel connector in the lower cover may be removed and the fuel hose from the fuel tank connected directly to the fuel pump. If this is done the opening left after the connector and around the fuel hose must be sealed to prevent extra air entering inside of cover.
20. Electric fuel pumps may be added provided the fuel still runs through the original fuel system and no parts are removed or blocked off.
21. No parts may be added to the motor unless specified in this rule.
22. It is allowed to extend the starter cord of a rewind starter so that the starting handle can be reached from the cockpit

## **554 - FUEL**

See 508.01, 508.02, 508.06, 508.07, 508.08, 508.09, 508.10, 508.11.

## **560 - INFLATABLE BOATS (P)**

*U.I.M. Class P750*

**560**    *General*

**561**    *Classes*

**561**    *Hulls*

**562**    *Machinery*

**563.1** *Surf Discipline*

**563.2** *Circuit Discipline*

**563.3** *Longhaul Discipline*

**564.1** *Modifications.[S]*

**564.2** *Modifications. [BP]*



**564.3 Modifications. [M]****564.4 Tech.Specs.**

*Note: To save repetition some existing U.I.M. Circuit Rules are referred to by their numbers only.*

*They are still totally relevant to all P750 Classes.*

**560 - GENERAL****560.10 - BEHAVIOUR**

*No abuse of officials will be tolerated .*

*Any driver, co-driver or team members found guilty by admission, or by the jury, will result in the driver/co-driver being disqualified from the heat or discipline or total event.*

*Only the O.O.D. or the U.I.M. Commissioner can take this action.*

*After a finding of gross infringement of the rules or a gross breach of good manners or sportsmanship, not covered by the above rule, the O.O.D. and/or the Race Jury may exclude a competitor from a heat/discipline or the whole event.*

**560.11 - PROTESTS**

*All protests, jury formation, sanctions, appeals are to be as the Rules 400 Series (as with all other U.I.M. classes).*

**560.12**

*The protest fee must be announced in the advance programme.*

### **560.13 - DANGEROUS DRIVING**

*Dangerous or reckless driving will lead to disqualification from that heat or discipline.*

*Intentionally causing damage to another boat or bodily harm to a competitor will result in disqualification from that discipline or the whole event.*

### **560.14 - ALCOHOL/DRUGS**

*Alcohol or drug abuse will result in a total ban from the event (see rule 205.02.02). All drivers must sign the Appendix 2 form of the Anti-Doping rules when first signing in at any U.I.M. race site.*

### **560.15 - DAMAGED HULL/ENGINE/LOWER UNIT**

*The hull, engine or any part thereof that is damaged beyond repair cannot be replaced during the actual discipline being raced for.*

*Exceptions:*

*An irreparable hull can only be replaced by another if the O.O.D. decides another competitor was responsible for the damage caused only during a race or training on the water.*

*Any damaged part of the engine can be replaced with similar except the cylinder block.*

*Underwater units that are damaged beyond repair, can be changed provided they have the same gear ratio and from a similar homologated engine.*

### **560.16**

*All changes must be sanctioned and supervised by the scrutineer or an appointed official.*

*All damaged parts including hulls must be kept in a secure place for any official inspection or pending possible protests.*

*Any equipment subsequently found to be repairable will result in the driver being eliminated from the complete event.*

*All costs pertaining to the stripping of additional equipment will be the responsibility of the competitor in question.*

*A fee, as specified in the advance programme, must be paid to cover the inspection of any protested engines or equipment.*

*These charges should be reasonable.*

*When different disciplines are held on different days and no fully secure compound is available either overnight or days then all boats must be re-scrutineered before racing re-commences. Failures will result in the loss of all previously gained points.*

## **560.17 - MINIMUM AGE**

*Minimum age for Class P750 [S] is 16.*

*Minimum age for Class P750 [BP] is 16.*

*Minimum age for Class P750 [M] is 18.*

*Minimum age for all co-drivers is 16.*

*Age refers at the date of the event.*

## **560.18 - OVERLAP**

*An overlap is established only when two boats are on the same course, or approximately on the same course, and the boats are parallel to each other if overtaking on the inside.*

*When overtaking from the outside an overlap is established when the overtaking boat has passed the overtaken boat sufficiently to change direction without contact.*

*The following rules shall apply to an overlap :*

*The lead boat has the right of way until an overlap is established.*

*A safe overlap is the responsibility of the overtaking boat.*

*Once an overlap has been established the overtaken boat must give the overtaking boat room to clear any course markers.*

*An overlap can occur from left or right.*

*An overlap may not be established on the inside of the actual race course.*

## **560.19 - RACE NUMBERS**

*Removable race number sizes on the boat and those on the engine cover must be 18cm x 3cm with a 2cm border around the number.*

*Their colour must be black letters on a white background.*

## **560.20 - START POSITIONS**

*The seeding and start positions: Please see the separate disciplines.*

## **560.21 - O.O.D.**

*The U.I.M. will approve the O.O.D. for all U.I.M. titled events.*

## **560.22 - FINAL INSPECTION**

*The organisers must ensure that at least the winning boat and engine are inspected and measured to ensure legality.*

*Optional to inspect or measure other boats in second or third places or any other boat. U.I.M. Rules 321.05 will apply.*

### **560.23 - YELLOW/RED CARDS**

*Yellow/Red cards : see rule 406.05. These rules will be strictly enforced.*

*They only apply to bad behaviour on the water.*

*Other penalties are available for bad behaviour on land.*

### **560.24 - DRIVERS BRIEFING**

*Any driver/co-driver failing to attend any drivers briefing will be disqualified at the discretion of the O.O.D.*

### **560.25 - INSURANCES**

*All drivers and co-drivers must abide by any mandatory medical and insurances carefully set out in the advance programme. Any costs charged by the organisers for supplying the same, must also be stipulated in the advance programme.*

### **560.26 - SPONSORS**

*Any event sponsor decals must be displayed in the boat windows if supplied free. Failure will result in not passing scrutineering.*

### **560.27 - PRIZE PRESENTATION**

*Prize presentation at U.I.M. Titled events must be attended by all participants.*

*Only the O.O.D. can sanction a non attendance.*

### **560.28 - MINIMUM BOATS NUMBERS AND NATIONAL AUTHORITIES**

*A minimum of four boats will constitute a valid class.*

***For a U.I.M. Titled event the minimum number of boats per class must be six and a minimum of three different countries (National Authorities).***

## **560.29 - LICENCE DETAILS**

***All drivers and co-drivers must hold a current International driving licence issued by their own National Authority.***

***U.I.M. Rules 120.01, 120.02, 120.03, 120.04, 120.05, 120.06, 120.07 will apply.***

## **560.30 - SCORING SYSTEM**

***Scoring for the three disciplines will be as follows.***

***All three disciplines have equal standing and must be awarded the same system of awarding points to find the overall winner, etc.,***

***In the event of a tie [Dead heat] then the number of firsts, seconds, third places etc.will be taken into account.***

***If still a tie then the position in the "Longhaul" discipline should be taken into account.***

<b><i>Position</i></b>	<b><i>Points</i></b>
<b><i>1</i></b>	<b><i>20</i></b>
<b><i>2</i></b>	<b><i>17</i></b>
<b><i>3</i></b>	<b><i>15</i></b>
<b><i>4</i></b>	<b><i>13</i></b>
<b><i>5</i></b>	<b><i>11</i></b>
<b><i>6</i></b>	<b><i>10</i></b>
<b><i>7</i></b>	<b><i>9</i></b>
<b><i>8</i></b>	<b><i>8</i></b>
<b><i>9</i></b>	<b><i>7</i></b>
<b><i>10</i></b>	<b><i>6</i></b>
<b><i>11</i></b>	<b><i>5</i></b>
<b><i>12</i></b>	<b><i>4</i></b>

13	3
14	2
15	1
16	0

*This system will be used to determine the winner of each discipline to go forward to find the overall winner in each class.*

## **560.31 - SAFETY EQUIPMENT**

### **HELMETS**

*For all racing helmets must be open faced or full faced motorbike helmets given to protect the skull base and cover the ears (except in Longhaul where lightweight open face helmets are allowed).*

*At least 50% {area} of the helmet must be of fluorescent orange, red, yellow or international orange colour.*

*The helmet colours must be bright enough to be clearly visible in the water.*

*The wearer is entirely responsible for the efficiency of his helmet.*

*The organisers are recommended to repeat this important rule in their advance programme and their race instructions.*

*As per rule 205.07*

## **560.32 - LIFEJACKETS**

*The efficiency of the lifejacket is the sole responsibility of the wearer who must be assured that it conforms with the U.I.M. rules and carries indelible confirmation of this.*

*Buoyancy: A lifejacket must have a minimum of 7.5kg solid buoyancy for a person weighing up to 60kgs and 9kgs of buoyancy for those over 60kgs. [closed cells only]*

*A back support is highly recommended.*

*As per rule 205.06*

### **560.33 - CARRIED SAFETY EQUIPMENT**

*Safety equipment as specified in each discipline must be carried at all times.*

*Failure to do so will involve penalties as described in the relevant discipline.*

*The boat number must be marked on all safety equipment.*

### **560.34 - EYE PROTECTION**

*Eye protection is mandatory in disciplines Circuit and Surf.*

*This protection can be goggles or helmet visor.*

### **560.35 - CLOTHING**

*All limbs must be covered at all times.*

*Cut resistant suits and protective gloves are mandatory as per rule 205.11.*

## **561 - CLASSES/HULLS**

<i>P750 S</i>	<i>Standard</i>
<i>P750 BP</i>	<i>Blueprint</i>
<i>P750 M</i>	<i>Modified</i>

### **561.01 - DISCIPLINES**

<i>Surf</i>	<i>Rule 564</i>
<i>Circuit</i>	<i>Rule 565</i>
<i>Longhaul</i>	<i>Rule 566</i>



## 561.02 - TITLES

*U.I.M. World Championship and U.I.M. Continental Championships:*

*Must include all 3 disciplines at a single event over a maximum duration of 8 days, including maximum of 2 lay-days.*

*No single discipline will be recognised for any U.I.M. Title.*

*All three disciplines must enjoy equal points awarding system.*

## 561.03 - TEAMS

*Team = designated driver and co driver can contest these championships.*

## 561.04 - ENGINES

	<i>P750 S</i>	<i>P750 BP</i>	<i>P750 M</i>
<i>Capacity</i>	<i>Up to 750cc</i>	<i>Up to 750cc</i>	<i>Up to 750cc</i>

## 561.05 - HULLS

	<i>P750 S</i>	<i>P750 BP</i>	<i>P750 M</i>
<i>Length. minimum</i>	<i>3.8m</i>	<i>3.8m</i>	<i>4.0m</i>
<i>Width. minimum</i>	<i>1.7m</i>	<i>1.7m</i>	<i>1.7m</i>
<i>Weight. minimum</i>	<i>153kg</i>	<i>153kg</i>	<i>160kg</i>

*The above mentioned weights are the minimum weight of a complete rig, weighed directly after the race without driver or residual water, but including residual fuel.*

*To reach the minimum weight, ballast can be added.*

*This must be screwed or bolted securely to the inside of the boat, but not exceeding 10% of the weight of the complete rig without ballast.*

## **561.06 - HULL DESIGN**

***All boats must be of a tunnel hull design and conform to the original manufacturers catalogue.***

***All boats must be fitted with a serial number plate issued by the manufacturer on either the noze cone or preferably the transom, showing the Model, Make, Date of Manufacture and if possible the maximum allowed horsepower of any relevant engine.***

***A minimum number of 2 boats must have been made, advertised for sale and are commercially available before the model can be accepted to race.***

***All boats must conform to the following measurements:***

***Sketch:***

***Measurements***

***Number 4: 0.26 to 0.27m. Rear Transom to ground:***

***Between hi-jackers at rear measured at nearest points:***

***Number 8: 1.05 to 1.10m. Overall width front transom  
{measurement taken at back of nose cone.}***

***(Other measurements to be added by agreement)***

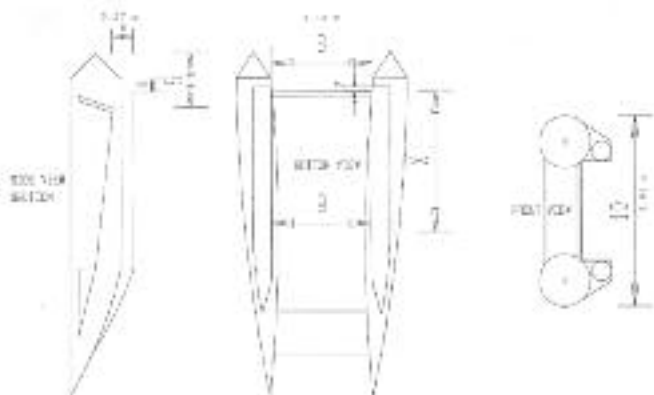
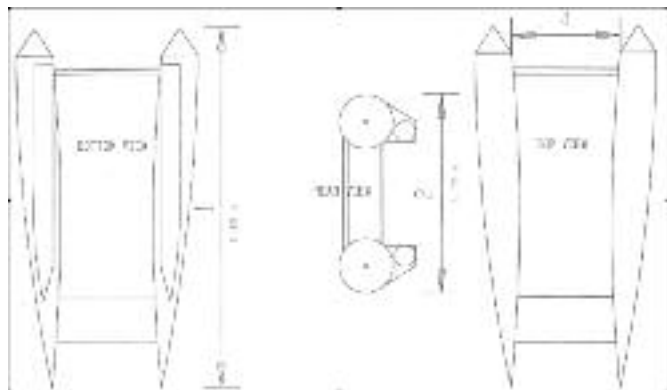

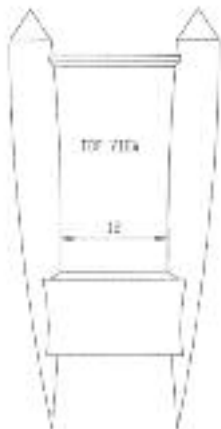

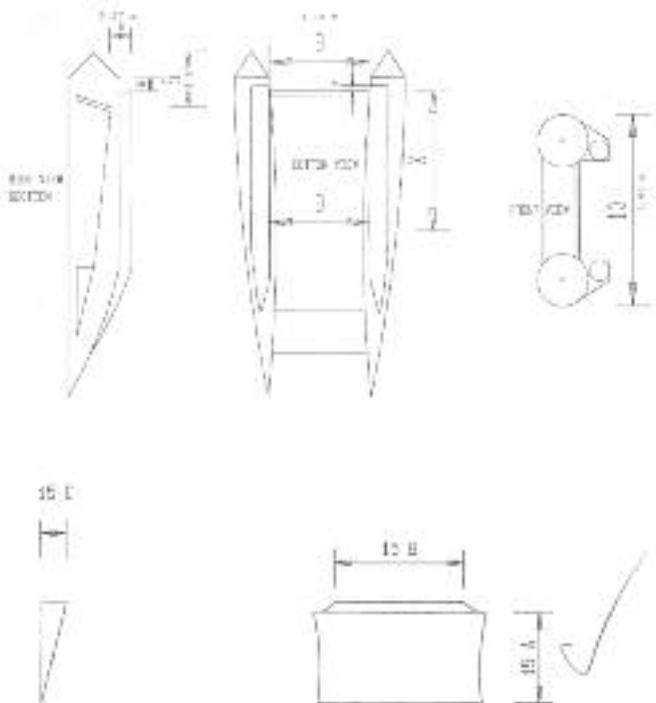

## 561.07 - INFLATION OF HULLS

*They can only be inflated with atmospheric air and must have 3 independant compartments, except for pencil type boats where each pontoon must have 2 independant compartments.*

*The boat must be able to float even if one compartment is not functioning.*

*Flexible foam hijackers are allowed.*

## **561.08 - DEFINITION OF HULLS**

*All boats should be able to deflate, to collapse, foldable or to be able to be rolled up, so that no dismantled part has a length greater than 1/3 of the full length of the inflated boat.*

*No aerodynamic appendages are allowed*

## **561.09 - MODIFICATION**

*Modifications above the waterline are allowed, These modifications will refer to foot straps, handles, loop patches only and not modifications that interfere with the original dimentions of the boat.*

*A waterline is defined as the line taken when the boat is ready to race but without the driver/co-driver.*

*The waterline will be below the bottom of the transom if a multi-hull type.*

## **561.10 - SPLASH PLATE**

*A splash plate may be fitted to the back of the transom as long as it complies with Rule 561.08 plus the following dimensions:*

*If this plate runs the full length of the transom, ie. from pontoon to pontoon, then the width of this plate is restricted to 100mm. If the width of this plate exceeds 100mm then it's length is restricted to 150mm across the back of the transom, but may protrude as far back as the engine as required.*

## **561.11 - MODIFICATION**

*Modifications below the waterline. Planing batons and strakes may be attached to the planing surface of the hijackers. Construction spray strakes are permitted anywhere on the outside of the hijacker cover.*

## **561.12 - WINDOWS**

*All boats must have two transparent windows 250mm x 700mm into which the event sponsor's decal may be placed.*

*They must be positioned to be clearly visible.*

*Boat numbers can be painted or enclosed in two transparent covers, meeting the correct size and clearly visible. Rule 560.19.*

## **561.13 - RIGHTING ROPES**

*All boats must be fitted with two designated righting ropes/webbing.*

*These ropes/webbing must not share common use.*

*They must be at least 10mm thick [rope] and the webbing minimum 25mm wide.*

*All boats must be fitted with a 4 metre length of similar material as a designated bowline, spliced or stiched eye at the end.*

*The bowline must be fixed to to the nosecone in a pouch glued/fixed to the nosecone. Bowline must not be tied up in other ropes of the boat and must be easily accessable to be able to hook into the towing point on the bottom side of the nosecone.*

*Towing points must be in the middle of the nosecones.*

*Any towing point must be capable of pulling 300kgs.*

## **562 - MACHINERY**

### **562.01 - CLASSES**

*P750 S*

*P750 BP*

*All engines must be homologated by the U.I.M..*

*The only outboard engines allowed in these classes are:*

*Tohatsu M 50D2.*

*Yamaha 50 H as per original homologation papers.*

*No other engine will be permitted until 1<sup>st</sup> January 2013 or three years after the U.I.M. [Powertrain Group] homologate a “low emission” compatible engine accepted by U.I.M. Cominsport.*

### **562.02 - CLASS P750 M**

*Only commercially available homologated engines are allowed in this class, including:*

*Tohatsu M 50D2*

*Yamaha 50H*

*Only these engines, modified according to the rules will be allowed to race until January 1<sup>st</sup> 2013, when the U.I.M. will no longer recognise this class for a U.I.M. Title.*

### **562.03 - LOW IDLE**

*All engines must be capable of functioning at low speeds.*

### **562.04 - WATER PICK-UP**

*External water pick-ups wherever attached are forbidden.*



## **562.05 - CONTROL HANDLE**

*An efficient control handle giving forward, neutral and backwards movement is mandatory.*

*The control handle for a functioning reverse gear must be within easy reach of the driver.*

## **562.06 - KILL SWITCHES**

*The manual starter must ensure a quick and easy start with no external aids.*

*The engine must be fitted with a “kill switch”, operated with a lanyard no longer than 1.3 metres.*

*The lanyard must be strong and very firmly fixed to the driver. A second “kill switch” lanyard must be firmly attached to the co-driver in Longhaul only.*

*Lanyard failure or kill switch failure will result in disqualification from the relevant heat/discipline.*

## **562.07 - IRREPAIRABLE DAMAGE**

*If a boat, engine, or any part thereof becomes irreparable only through racing incident on the water, then :*

- The hull may be replaced.*
- The engine may be replaced.*
- The engine can be re-built.*
- The underwater unit may be replaced.*

*All subject to official inspection and official authorisation before any attempt is made on replacement or repairs (see rule 560.15 - 3<sup>rd</sup> paragraph).*

## **562.08 - GEARBOX**

*The gearbox shall not be interferred with. Any normal wear and tear on the fin shall be limited to 5mm and must be seen to be racing wear and tear.*

*If found not to be then the driver will be disqualified from that heat or discipline.*

*A stainless steel cover , with the same characteristics as an original gearbox, can be used to protect the leading edges.*

## **562.09 - SOLE MODIFICATIONS ALLOWED**

*1 - The original propeller may be replaced by any other three blade, through the hub propeller.*

*2 - Original complete spark plugs and HT leads may be replaced.*

*3 - You may use rev.counters.*

*4 - All auto lube and any relevant parts may be removed.*

*5 - Rev limiters may be removed (only in M and BP classes).*

*6 - Re-boring is only allowed in [BP] and [M] classes.*

*Parts must be as supplied by the original manufacturer.*

*No aftermarket parts can be fitted.*

*Oversize pistons can be fitted providing the total ccs does not exceed 750ccs.*

### **NO RE-BORING IN STANDARD [S] CLASS**

*7 - The steering bar and brackets may be re-inforced and additional steering bars may be mounted.*

*The steering bars must be able to tilt independantly from the engine. Strengthening of the transom bracket and lower leg are allowed.*

- 8 - A maximum 1 x 6 mm hole may be drilled in the airbox to allow any water to drain.**
- 9 - Engine mountings may be replaced with rigid or rubber mounts with similar characteristics.**
- 10 - Springs may be added to the throttle lever of the carburettors.**
- 11 - Carburettor main jets may not be changed or modified [S and BP classes].**

**EXCEPT in Standard Class [S] where no modifications are allowed**

- 12 - Emulsion tubes are to be standard "off the shelf" items and have the same pre-requisites as the jets. No modifications are allowed to these parts (excludes S Class).**
- 13 - The replacement of nuts or the addition of lock nuts, drilling, wiring, split pinning or key ring is allowed provided the screws and pins are similar to the original parts.**
- 14 - The gear interlock on the starter may be removed.**
- 15 - Motor "locking" brackets may be removed.**
- 16 - Baffle plate or other fuel surge preventative measures can be taken in carburettor fuel bowls.**
- 17 - The engine cowling must be securely fastened by additional means as necessary.**
- 18 - Alternative telltale cooling pipes may be fitted.**
- 19 - The crankshaft may be welded or pinned and must still meet the original manufacturers dimensions.**

#### **20 - CLASS [BP] ONLY**

**Only parts where the dimension is quoted in the homologation specification, may be altered for the purpose of reaching that specific measurement.**

**The shape of the parts cannot change.**

*{eg. The shape of the cylinder head squish pan}*

*The Block height measured from the centre line to the top of the block is allowed, all measurements according to U.I.M. homologation papers.*

#### **21 - CLASS [BP] ONLY**

*A part, the weight of which is quoted in the homologation sheet, may be machined for the specific purpose of reaching the quoted weight only.*

*It is not allowed to change the flywheel, but balance machining is allowed if the dimensions and weights are still correct.*

#### **22 - CLASS [BP] ONLY**

*Measurements not quoted in the homologation sheet may not be altered in any form whatsoever.*

*If details cannot be verified with the aid of the pictures in the homologation sheet, then the part in question must be compared physically to a similar, but stock part.*

#### **23 - CLASS [BP] ONLY**

*No part of the engine can be changed with alternative parts other than:*

- Tiller arm.*
- Tiller arm bracket.*
- Gear change lever.*

#### **24 - CLASS [BP] ONLY**

*25 - It's allowed to change bearings with similar characteristics.*

*26 - Steering dampers may be fitted.*

*27 - Steering by a steering wheel or tiller arm is acceptable.*

## **562.10 - FUEL**

*Fuel must be commercially available grade of automobile fuel, freely available from any normal petrol station.*

*To maximise the equality of competition and to simplify the checking of conformity, the organisers must arrange the supply of the same fuel for all competitors at all U.I.M. titled events.*

*It does not of necessity have to be free of charge.*

## **562.11 - OIL**

*A sample sealed container of the oil used, will be supplied by the competitor with unbroken seal, and then held by the organisers for the duration of the event in the event of fuel tests.*

## **562.12 - FUEL TANKS**

*Only the original fuel tanks as supplied with the engine, collapsible fuel cells or approved marine manufacturers tanks are allowed.*

## **562.13 - FUEL MIX**

*No driver may withhold the type of fuel/oil used and the mixing ratio if requested by officials.*

## **563.1 - SURF DISCIPLINE**

### **563.1.01 - STANDARD COURSE**

*The standard course for Surf Discipline is shown diagrammatically in Annexe A.*

*All starts will be from the beach.*

**Note:** *There does not have to be breaking Surf in order to engage this discipline. Although it must take place on a suitable beach.*

## **563.1.02 - GRID POSITIONS**

*The first heat of any championship has to be authorised by the organisers.*

*At all U.I.M. titled events the following will apply.*

*The grid positions for the first heat of the surf discipline, provided the Circuit Discipline has not been completed first is as follows:*

*The competitors will line up according to their respective positions in the corresponding event the previous year [eg. If World championship 2010 then the final positions in the World championship 2009, or previous year if the championship has not occurred. Similar for U.I.M. Continental championships].*

*Other new competitor will line up after those, but in the order that they sign on at the race site at the start of the event.(Alternatively the organisers may decide to draw the names of the new entrants from a hat).*

*Only the driver's names are taken into account when forming the final grid positions. Any co-drivers names are discounted.*

*Should the organisers hold the Circuit Discipline first, before the Surf, then the grid positions for the first heat in Surf, will be as the official positions in the Circuit Discipline.*

*The grid positions for the second heat will be as they finish the first heat.*

*The grid positions for the Final heat will be the aggregate positions [points] of the first and second heats.*

*In the event of a tie, then the fastest time recorded on the day in either heat by the boats involved will break the tie.*

### **563.1.03 - WET DRIVER**

*If any driver/co-driver lands in the water or a boat gets stuck on the beach during racing, the race will be stopped immediately, even before the red flag is flown.*

*All competitors must stop, then clear the course and proceed to the start line with extreme caution.*

*No re-fueling and get ready for an immediate re-start.*

*Maximum 2 re-starts.*

*The boat causing the stoppage is not allowed in any re-start of that heat.*

*Any penalty is carried forward to any re-start of that heat.*

*Any boat that gets stuck on the beach may only re-start with the O.O.D.'s permission.*

*If more than 2/3 of the race [or re-started race] has been completed then no restart.*

*If the second re-started race is stopped before 2/3 has been completed then 50% of the points are awarded irrespective of the laps scored.*

### **563.1.04 - RACING BUOYS**

*If a competitor misses or rides over a buoy and crosses the racing line on the inside of the course, he will be disqualified from that heat.*

### **563.1.05 - DAMAGING BUOYS**

*If a competitor destroys a buoy he will be disqualified from that heat.*

*The competitor will pay the organiser the cost of a replacement which sum must be in the advance programme.*

*If not in the advance programme, then the competitor can refuse to pay without penalty.*

### **563.1.06 - BUMPING**

*Deliberate bumping of buoys or of another competitor is strictly forbidden and will result in the disqualification from that heat or the whole discipline.*

### **563.1.07 - CRASHING**

*If one boat lands on another, the offending boat or boats will be disqualified from that heat.*

### **563.1.08 - CLOSE DRIVING**

*A boat who follows dangerously close to another boat may receive a yellow card or on repetition during the discipline, may be disqualified from that discipline.*

### **563.1.09 - T-BONE**

*If any boat collides midships with another {T-Bone} this will result in immediate disqualification from that heat of the offending boat.*

### **563.1.10 - SHORE BUOYS**

*There should be a minimum of 10 metres between the shore buoys and the shore.*

### **563.1.11 - RACE DISTANCE**

*All heats including the final will be 9 laps for all classes.*



### **563.1.12 - RACE FINISH**

*After finishing a heat all boats must proceed around the next buoy beyond the finish buoy/line and wait for the Red flag in order to proceed back to the shore.*

*Boats failing to do this will be disqualified from that heat.*

*Any boat failing to complete 2/3 of the race [completed laps "rounded up"] when the winner crosses the finish line, will no score in that heat.*

*Boats running out of fuel before the finish line will not score in that heat and may invoke further penalties.*

### **563.1.13 - MINIMUM/MAXIMUM BOATS**

*There will be minimum 3 and maximum 12 boats to make a race.*

*In the event of the entry exceeding 12 boats, then eliminating heats will be run as follows:*

*All boats must be divided up into equal groups and each group will contest two qualifying heats with normal points awarded.*

*The top 12 boats from either of the qualifying heats will contest the final.*

*The final heat for all classes will be 9 laps.*

*If eliminating heats are run, then the final heat will be awarded Double points.*

### **563.1.14 - AWARDING POINTS**

*The total points for the two [2] qualifying heats plus the final heat will be added together to determine the drivers final placing for positions 1-2-3 to 12 position. Position 13 downwards will be awarded points as from the qualifying heats. Position 15 and remainder of the finishers in the heats all receive 1 point.*

### **563.1.15 - START SURF**

*The start will be as follows:*

*Both driver and co-driver will be out of their boat, the kill switch may be plugged in. On the drop of the starter's green flag, the race will start.*

*Both hands of the driver must be on the anti-hogging rope.*

*Both feet of the driver and co-driver must remain on the ground at all times up to the green flag drop.*

*The driver must have both feet on the floorboard of his boat before he can start his engine.*

*The co-driver cannot start the engine at the start.*

*Failure to abide by any of these rules will result in a Yellow card and moved to the lower end of the grid.*

*Due to surf conditions, the start may be changed after consultation between the O.O.D. and a driver's single representative for all classes.*

### **563.1.16 - START LINE**

*Any driver not on the start line when the green flag is raised may not start that heat or any re-start of that heat.*

*Any driver that fails to start when the green flag is dropped may only enter the racecourse when it is safe to do so.*

*This is only allowed if the leading boat has not completed one lap.*

*One back-up crew per team is allowed to assist at the start provided he is positioned opposite the driver at the start.*

*Only drivers that were on the start line and failed to start can take part in any re-start of that heat.*

*Any driver/co-driver jumping the start either by starting his engine early or not observing the feet on the ground rule, will receive a yellow card and be moved to the lower end of the grid.*

*A second offence will mean disqualification from that heat.*

### **563.1.17 - RESTARTS (SEE ALSO WET DRIVER RULE 563.03)**

*Re-start of a heat/final will be done with a pace boat, either on the back straight if adverse weather conditions or from the beach if the water is in good condition.*

*In both cases of re-starts all boats must muster at the area of buoy 2 {second turnbuoy} and a green flag will be used.*

*All boats must keep their positions as per the previous lap and follow each other closely.*

*Boats are not allowed to overtake or change positions until the green flag is dropped. The official will monitor grid positions prior to the re-start.*

*Any driver changing positions during the run up to the starter or when under starter's orders will be disqualified.*

*Laps will be reduced from 9 to 6 to 4 respectively.*

### **563.1.18 - BURST HULL/HELMET LOSS**

*If a boat should burst or deflate rapidly during a race for any reason, that boat must immediately stop racing and clear the course.*

*Similarly if a driver or co-driver loses his helmet, they must cease racing and further penalties may be applied if the loss was due to driver/co-driver error.*

### **563.1.19 - FLAGS**

*All flag signals except the green flag will conform to the U.I.M. Rule 304.02.*

### **563.1.20 - FLAG ACKNOWLEDGMENT**

*All competitors must acknowledge all flag signals to the official giving the signal.*

*Failure may lead to disqualification or loss of 2 points.*

### **563.1.21 RACE LIVE**

*The race will be live when the green flag drops.*

*The heat is live when the last running boat crosses the start/finish line for the first time.*

*If the last boat has not passed the start/finish line, then the re-start is for the full amount of laps with no re-fuelling.*

### **563.1.22 SAFETY EQUIPMENT**

*All boats must always carry the following safety equipment.*

*Paddles x 2*

*Designated righting rope/webbing x 2*

*Designated Bowline.*

*Kill switches x 2*

*[See separate Disciplines for additions to the list.]*

## **563.2 - CIRCUIT DISCIPLINE**

### **563.2.01 - ELIMINATING HEATS**

*In the event of there being more than 12 boats, elimination heats will be run as follows:*

*The drivers will be divided up into equal sections and each section will run 2 qualifying heats with points to count.*

*The top qualifiers will go forward into the final heat consisting of maximum 12 boats.*

*Points for the final heat count double.*

### **563.2.02 - GRID POSITIONS**

*Grid positions, if run after the Surf Discipline, will be as they finished in the Surf Discipline.*

*Evenly split up into the two heats irrespective of nationality.*

*E.g., Surf position 1 into heat 1. Surf position 2 into heat 2. Surf position 3 into heat 1 etc.,*

*If circuit discipline is the first discipline of the event then:*

*At all U.I.M. titled events the following will apply.*

*The grid for the first heat of circuit discipline is as follows:*

*The competitors will line up according to their positions in the corresponding event the previous year [eg. If U.I.M. World championship 2010 then the final positions in the World championship 2009, or previous year if not occurred. Similar for U.I.M. Continental championships].*

*Other new competitors will line up after those but in the order that they sign on at the race site at the start of the event.*

*Alternatively the Organisers may decide to draw the names of the new entrants out of a hat.*

***Only the driver's names are to be used when deciding the whole grid positions. Co-drivers names are discounted.***

### **563.2.03 - MISSING BUOY**

***If a driver misses a buoy, touches, bumps or rides over a buoy, he cannot re-take it and is disqualified from that heat or any re-starts of that heat.***

### **563.2.04 - DESTROY BUOY**

***If a driver destroys a buoy he will be disqualified from that heat and any re-starts of that heat. He will pay the organiser the cost of a replacement, which sum must be in the advance programme. If not in the advance programme then the driver can refuse payment with no penalty.***

### **563.2.05 - BUMPING**

***Deliberate bumping of another boat will result in disqualification from that heat and any re-starts and may be disqualified from the whole Discipline.***

### **563.2.06 - CRASH LANDING**

***If one boat lands on another, the offending party or parties will be disqualified from that heat.***

### **563.2.07 - CIRCUIT RACE COURSE**

***The standard course for Circuit racing is shown diagrammatically in Annexe B.***

***The start is from a pontoon. [Jetty]***

### **563.2.08 - T-BONE**

*If any boat collides mid-ships with another boat {T-bone} this will result in disqualification of the offending boat or boats from that heat.*

### **563.2.09 - STRAIGHT START: CIRCUIT.**

*The start, all drivers must keep their line to and through the first turn.*

*Drivers must not change lanes in front or behind other drivers until they have passed and rounded the first buoy, or they will be disqualified from that heat.*

### **563.2.10 - FLAG OR JETTY START FROM PONTOON. CIRCUIT**

*Starts will utilise two flags system with both drivers and co-drivers in their boats.*

*Both flags are raised and on dropping the first flag, the engine can be started in neutral.*

*As an alternative start procedure the organisers can use the:*

*Dead-engine start as per rules 307.01, 307.02, 307.03, 307.04, but only if it is stated in the advance programme.*

*On dropping the second flag, forward gear may be engaged and the race starts.*

*All drivers must complete a "long lap" as a first lap.*

*This does not count as one of the compulsory equaliser laps.*

*If a boat jumps the start for the first time, he moves to the end of the pontoon.*

*If the same boat jumps the start again, they will be disqualified from that heat.*

*If another different boat also jumps the start after a previous jumped start, that boat will then be moved to the end of the grid next to the first offender.*

### **563.2.11 - EQUALISER LAPS**

*Each driver must complete 2 laps of the equaliser circuit during each heat. Failure to do 2 laps will result in disqualification from that heat.*

*Equaliser laps must be completed after the first lap and before the start of the final lap.*

### **563.2.12 - LAPS**

*All heats will be 9 laps for all classes of P750.*

### **563.2.13 - RACE FINISHED**

*After finishing a heat all boats must proceed around the next buoy after the finishing line and wait for the Red flag before returning to the shore, pit area.*

*Drivers failing to do this will be disqualified.*

*Boats that have not completed 66% of the race [full laps rounded up] when the winner crosses the finish line will not score any points for that heat.*

### **563.2.14 - MINIMUM/MAXIMUM BOATS**

*There will be a minimum of 3 and a maximum of 12 boats in any heat.*



### **563.2.15 - FINAL POINTS**

*The total points for the 2 eliminating heats plus the final heat, will be added together to determine all the competitors final placing from 1—12. Positions 13—20.*

*Position 13 downwards will be awarded as from the eliminating heats. Position 15 and remainder of the finishers in either heat will receive 1 point.*

### **563.2.16 - WET DRIVER RULE**

*Rule: 563.1.03*

*[Rule Not repeated here.]*

*But driver/co-driver in the water during racing then all racing must stop and return slowly to pontoon/pits.*

### **563.2.17 - HULL BURST**

*If a boat should burst or deflate rapidly during a race for any reason, that driver must cease racing and remove the boat from the race course.*

### **563.2.18 - HELMET LOSS**

*If a driver or co-driver loses his helmet, they must immediatel stop racing and return to the pit area.*

*Further penalties may be invoked if enquiries lead to a failure due to any error by the person incurring the loss.*

### **563.2.19 - RESTARTS**

*If more than 2/3 of the race have been completed [full laps rounded up], by all the boats running, there will be no restart and the results*

*will be taken in the order that the boats last passed the finishing buoy/line.*

*The boat causing the stoppage doesn't score or go into any restart.*

### **563.2.20 - FLAGS**

*All flag signals will conform to the U.I.M. Rule 304.02.*

*Except the Green Flag.*

### **563.2.21 - FLAG ACKNOWLEDGEMENT**

*All drivers or co-drivers must acknowledge all flag signals to any official giving the signal.*

*Failure may result in disqualification or the loss of 2 points.*

### **563.2.22 - RACE START CIRCUIT**

*The race will be live [Start] when the Green flag drops.*

*The heat is live when the last boat running crosses the start/finish line.*

### **563.2.23 - SAFETY EQUIPMENT**

*All boats must always carry the following safety equipment during the event.*

*See rule 563.1.22 for Surf/circuit*

*See rule 563.3.07 for LongHaul.*

## **563.3 - LONGHAUL DISCIPLINE**

### **563.3.01 - INLAND/OFFSHORE**

*All longhaul disciplines must be run over a maximum distances of 150kms and if the weather conditions prevent this, then it can be reduced to minimum 130kms. Minimum lap distance of 15 kms. Longhaul should be area bound.*

### **563.3.02 - ULTRA LONGHAUL**

*Over 150kms.*

*The organising National Authority will provide an extended list of extra rules for each event, including race regulations to be read in conjunction with the U.I.M. Rules.*

### **563.3.03 - TIMES**

*All longhaul events will be run on times.*

### **563.3.04 - COURSE DEVIATION**

*Deviation from the set course markers will result in disqualification from the race.*

### **563.3.05 - OUTSIDE ASSISTANCE**

*No person shall provide or receive outside assistance from the air, water or by radio during the race.*

*Failure to observe this rule will result in disqualification from the race.*

### **563.3.07 - SAFETY EQUIPMENT**

*In a longhaul event the following safety equipment must be carried at all times.*

*All critical equipment should be clearly marked with the boat number.*

*Smoke Marker [in date]. Hand held is acceptable.*

*Toolkit. [flipkit] including complete spark plugs.*

*First aid kit.*

*Pencil Flares x 6. [in date].*

*1m x 3m ID sheet for boats whose pontoons are not Red, Yellow or Orange in colour.*

*Anchor 1.5kg with chain 2m [min: 4mm thick].*

*Anchor rope x 30m.*

*Drogue anchor.*

*Paddles x 2 [two] attached to the boat.*

*Space blankets x 2.*

*Emergency water x 2 litres.*

*1000 ft Flares x 2.*

*Orange flag, min 0.6 x 0.4m. and means of hoisting, to indicate retirement.*

### **563.3.08 - RACE FINISH**

*A boat must cross the finish line under power or by paddle to receive an elapsed time.*

### **563.3.09 - CO-DRIVER INJURED**

*In the event of a co-driver being injured a replacement of the co-driver only is permitted in all disciplines if:*

- The hull may be replaced.*
- A doctor/Paramedic's certificate is produced stating that the injury is serious enough to prevent him continuing to race.*
- The O.O.D. is satisfied with the doctor/paramedic's report.*
- The replacement co-driver has the complete current paperwork including a current international licence.*
- No co-driver can be changed during a heat, leg or discipline.*

### **564.1 - P.750 (S) STANDARD CLASS : SOLE MODIFICATIONS ALLOWED**

#### **564.1.01**

*All engines must be U.I.M. homologated engines.*

*All engines must be a standard engine as supplied by the manufacturers and not modified in any way.*

*That means: straight out of the box*

*Only modifications allowed, as previously stated, which must not be power enhancing.*

*No re-boring of standard engines. [Rebored engines allowed in BP and M classes.]*

*No cylinder head skimming or grinding.*

*No "work" on the engine. Standard is standard.*

*No skimming, grinding or machining of any part is allowed.*

*No electric starters.*

***Thermostats are not to be removed.***

***Rev, limiters, heat sensors and lighting coils may not be removed.***

***Rev limiter wires must be continuous and connections to be soldered.***

***Any restriction of the efficiency of the rev counter is banned and a penalty up to disqualification may be imposed.***

***It is allowed to:***

- ***Change complete spark plugs (as well as plug tops for security).***
- ***All auto lubes may be removed, together with the relative parts.***
- ***The rubber engine mountings may be replaced with solid or mounts with similar characteristics.***
- ***Springs may be added to the throttle lever of the carburettors.***
- ***The carburetion and ignition advance controls may be tuned differently, but without altering the original parts.***
- ***Only the following jets are allowed.***

***Tohatsu M50D2***

***Top cylinder 132***

***Middle cylinder 132***

***Bottom cylinder 135***

***Yamaha 50H***

***Top cylinder 125***

***Middle cylinder 125***

***Bottom cylinder 125***

## **564.1.02 - ALLOWED**

***The replacement of nuts or the addition of lock nuts, drilling and wiring, split-pinning or keying is allowed provided the screws and pins are similar.***

### **564.1.03 - GEAR INTERLOCK**

*The gear interlock device on the starter may be removed.*

### **564.1.04 STEERING BAR/BRACKETS**

*The steering bar and brackets may be re-inforced and additional steering bar may be mounted.*

*The steering bars must be able to tilt independently from the motor.*

*Strengthening of transom bracket and lower leg are permitted.*

### **564.1.05 - ENGINE LOCK**

*Engine locking brackets may be removed.*

### **564.1.06 - ENGINE COWLING**

*The engine cowling may be secured by means other than or in addition to the standard means.*

### **564.1.07 - COOLING PIPE**

*Telltale cooling pipe may be replaced with another pipe or other characteristics.*

### **564.1.08 - SPLASH PLATE**

*A splash plate may be fix to the trunk of the motor as long as it is not rigid and that it is fitted above the cavitation plate.*

### **564.1.09 - CRANKSHAFT**

*The crankshaft may be welded or pinned as long as the dimensions of the crank after welding do not exceed the original manufacturer's dimensions and weight for crankshaft.*

### **564.1.10 - PROPELLER**

*The original propeller may be replaced by any other three blade propeller, provided that it has a through the hub exhaust.*

*No ventilation allowed.*

### **564.1.11 - RE-BORING**

*Not in Standard [S] Class.*

### **564.1.12 - PARTS INTERCHANGE**

*No part of the engine can be changed with another manufacture's or pirate part, except for the tiller arm bracket, gear change lever.*

### **564.1.13 - ENGINE HOMOLOGATION**

*It is the competitor's responsibility to ensure that his engine is within the legal requirements with regards to the homologation specifications.*

*Ignorance of the above will not be accepted as a defence and he will therefore be disqualified as in terms of Rule 563.01 and 563.02.*

### **564.1.14 - AIRBOX MODIFICATION**

*1 x 6 mm hole may be drilled in the lowest part of the air box to allow water to drain from it.*



## **564.1.15 - MODIFICATIONS NOT ALLOWED**

### **564.1.16 - MACHINING**

*No skimming, grinding or machining of any part is allowed.*

*Standard [S] only.*

### **564.1.17 - STARTERS**

*Electric starters are not allowed.*

### **564.1.18 - THERMOSTATS**

*Thermostats of the cooling circuit may not be removed.*

### **564.1.19 - REVOLUTION LIMITERS**

*Rev limiters, heat sensors and lighting coils may not be removed.*

*Rev limiter wire connections must be continuous and must be soldered to achieve this. Anything that might restrict the revlimiter in it's proper function will be classed as an infringement of this rule.*

*Ignorance of the above will not be accepted as a defence and the competitor will be disqualified.*

## **564.2 - FOR (BP) BLUE PRINT CLASS**

### **564.2.01**

*Any work is permitted on the engine in order to meet any measurement included in the relevant Homologation Papers as supplied from the original manufacturers.*

*No measurement means no alteration.*

*Other relevant restrictions/allowances are included in these rules.*

## **564.3 - P750 (M) MODIFIED CLASS**

### **SOLE MODIFICATIONS ALLOWED**

#### **564.3.01- PROPELLORS**

*Propellers are free.*

#### **564.3.02 RE-BORING**

*Re-boring is allowed up to a maximum of 750cc.*

#### **564.3.03 - JETS**

*Jets are free.*

#### **564.3.04 - GEARBOXES**

*Bullet or racing gearboxes are allowed.*

#### **564.3.05 - CRANKSHAFT**

*No restrictions on welding of the crankshaft.*

#### **564.3.06 - DIMENSIONS**

*No restrictions on dimensions quoted.*

#### **564.3.07 - WEIGHTS**

*No restrictions on weights quoted.*

**564.3.08 - NO QUOTED MEASUREMENTS**

*Measurements not quoted in the homologation sheet may be altered.*

**564.3.09 - INTER-CHANGE PARTS**

*Parts may be changed with another manufacturer.*

**564.3.10 - HOLES**

*Holes may be drilled or cut into the exhaust trunk, but no external appendages may be added.*

**564.3.11 - NO PROTRUSIONS**

*No protrusions other than standard are allowed.*

**564.3.12 - EXHAUST BOX**

*No protruding expansion exhaust box.*

**564.3.13 - ENGINE COWLING**

*Engine cowling may be altered to increase air flow.*

**564.3.14 - EXTERNAL WATER PICK-UP**

*External water pick-ups are allowed.*

**564.3.15 - HOMOLOGATION**

*The competitor does not have to ensure that the engine conforms to the homologation requirements.*

### **564.3.16 - FUEL**

*Only fuel to a maximum of 102 octane is allowed. This includes avgas.*

### **564.3.17 BANNED FUEL**

*Special racing fuels, methanal, nitro-methane and the likes thereof are expressly forbidden.*

*The use of additives aimed at increasing the power of the engine is prohibited to either the fuel or the air intake.*

*The use of nitrous oxide injection is also totally prohibited.*

### **564.3.18 FUEL DETAILS AVAILABLE:**

*The driver may not withhold the type of fuel/oil used if requested by race officials.*

## **564.4 - TECHNICAL SPECIFICATIONS**

*The following section provides assistance and clarity on a number of technical areas.*

### **564.4.01 - PISTONS**

*Where a dimension is quoted on a piston, metal may be removed to reach a specific weight, provided the dimensions are maintained.*

*Should there still be an excess of weight, this may be removed from the inside of the piston i.e. the inside of the skirt or the area where the gudgeon pin goes through. This rule excludes the [S] standard class.*

### **564.4.02 - FLYWHEEL**

*Holes maybe drilled in the flywheel to reduce weight.*

*It is not allowed to reduce the outside diameter or to reduce the thickness at any point. This rule excludes the [S] standard class.*

### **564.4.03 - CRANKSHAFT**

*Holes maybe drilled in the crankshaft to reduce weight.*

*It is not allowed to reduce the diameter of the crankshaft.*

*This rule excludes the [S] standard class.*

### **564.4.04 - CONNECTING RODS**

*It is allowed to reduce the overall weight of the conrods by removing the flashing on the on the shank of all three rods to attain the weight specified provided for in the homologation specifications.*

*This rule excludes the [S] standard class.*

### **564.4.05 - ELECTRICAL COMPONENTS**

*It is allowed to remove any excess wiring i.e., heat sensors, rev limiters, low oil sensors etc.*

*It is forbidden to modify coils, to rewire coils or other components, to tamper with CDI units or to add any electrical components (starter etc.) or any other part that is not standard original part.*

*This rule excludes the [S] standard class.*

### **564.4.06 - HEAD VOLUME**

*It is allowed to encroach into the squish pan area in the skimming process as long as the minimum combustion chamber is maintained.*

*It is not allowed, should this minimum be exceeded, to remove the metal within the squish pan area to regain the lost volume.*

*Measurement of the head volume will be taken with the head removed from the block.*

*This rule excludes the [S] standard class.*

### **564.4.07 HEAD VOLUME STANDARD [S] CLASS**

*Tohatsu M 50D2*

*Yamaha 50H*

*All volumes according to the U.I.M. homologation papers.*

### **564.4.08 HEAD VOLUMES - BLUE PRINT [BP] CLASS:**

*Tohatsu M 50D2*

*Min head volume: 25.0 cc for all 3 (three) cylinders.*

*Yamaha 50H*

*Min head volumes 27.7 ccs for all 3 (three) cylinders.*

### **564.4.09 - HEAD VOLUME MEASURING PROCEDURE**

*The head volume is measured off the block, using a glass plate of minimum 3 mm thick.*

*A burette calibrated in 50 cc increments to be used with a paraffin/oil mix of 50/50.*

*All head volumes to be taken with a B8HS10NGK Plug correctly fitted.*

*The head is measured with no gasket.*

*All old gasket material is allowed to be cleaned off.*

*It is also allowed to clean all carbon deposit's in the head.*

*The glass plate must be sealed with a thin layer of marine grease*

#### **564.4.10 PORTS/TRANSFER/BOOST AND EXHAUST**

*It is allowed to blend the aluminium track to a depth of 10 mm measured from the outside of the liner bore to the track behind the port window. (Not applicable to M class, no restriction).*

*Should the modified port window be smaller than the track, the track may not be tampered with.*

*This excludes the [S] standard class.*

#### **564.4.11 KILL SWITCHES**

*It is allowed to exchange kill switches from one manufacturer to another.*

*However, the toggle type switch that can be activated without the insertion of the "curly cord" if forbidden.*

*This excludes the [S] standard class.*

#### **564.4.12 - THROTTLE ADVANCE**

*On various models it is allowed to change the position of the throttle cable link pin on the advance cam. It is not allowed to modify the cam itself or change the radius on the cam. This rule excludes the standard [S] class.*

### **564.4.13 COSTS FOR INSPECTION**

*Costs may not be claimed in the case of a mandatory inspection by race authority. The maximum costs that may be claimed, by a driver from a protestor, should the equipment found to be legal, are as follows:*

#### **LABOUR**

*Time may only be claimed to a maximum of six hours at a rate to be determined by their local class association or National Authority.*

*Any excess will be borne by the owner of the equipment.*

*The above costs excludes the cost of gaskets required or lubes which may only be changed as per the recommended grade in the workshop manual.*

*Freight charges, where applicable, will be charged as per the standard international rates.*

### **564.4.14 - TECHNICAL INSPECTIONS**

*The O.O.D. or official scrutineer will be in charge.*

*Only the following may attend the post-race engine inspections regardless of a protest being lodged.*

- O.O.D.;*
- U.I.M. commissioner;*
- Measuring Officer;*
- Driver and his mechanic (or representative);*
- Protestor or his representative;*
- Any other person the O.O.D. requires, with his permission.*

*Note that in the case of a protest, the protestor's duty is to ensure that the inspection complies with his protest requirements.*

*He may not however physically inspect the parts himself and should not be allowed within a 5m radius of the equipment.*



### **564.4.15 - STANDARD PART**

*In the case where original parts are not available, permission must be obtained from the U.I.M. Powertrain Committee to use substitute components.*

*Such a request must be in writing.*

*Any outboard motors that have superseded engine parts that may be used on older models may only be used if the older parts are not available and a superseded list is supplied by the factory and confirmed in writing by the U.I.M. Powertrain Committee. It is not allowed to interchange parts from one homologated model to another.*

*Substitution of parts is not allowed in the [S] standard class.*

*Running production changes are allowed.*

### **564.4.16 - FUEL**

*See rules 566.44 for Class [M] and Rule 508.01 for standard [S] class fuel regulations.*

*Oil to be supplied by competitor unless otherwise specified.*

### **564.4.17 - OVER-BLENDED AND SPARK ERODED ENGINES**

*Engines not conforming to U.I.M. and manufacturers homologation specification with regard to the blend rule and that have had tract widening done by any method inclusive of spark eroding, will only be allowed to compete in the modified class.*

### **564.4.18 - POST RACE INSPECTION**

*The post race inspection is to be a complete inspection and is not to be limited to any specific area.*

*Post race inspection should mainly be about speed and power enhancing matters.*

#### **564.4.19 - FAILURE TO APPEAR**

*Any competitor refusing to have his racing equipment inspected for legality at any reasonable time during the whole event will be disqualified.*

## **ANNEXURE A**

### **International SURF Circuit**

\* MUSTERING AREA  
RE-START

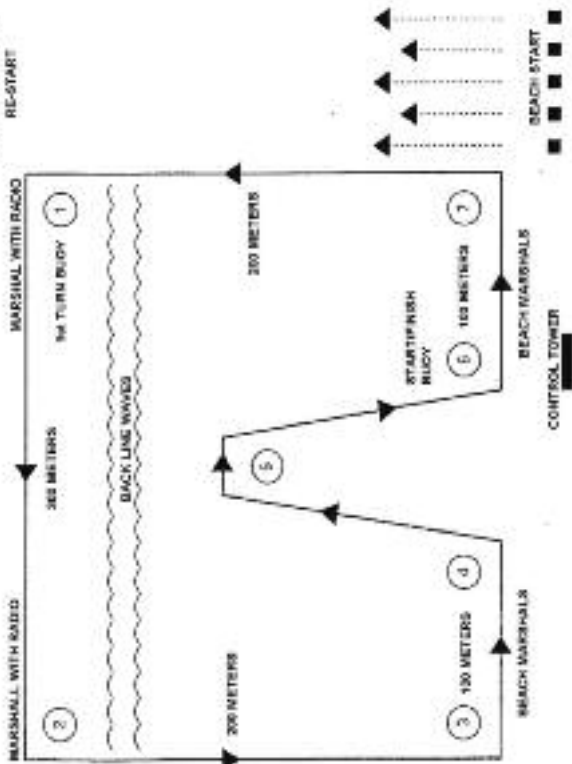

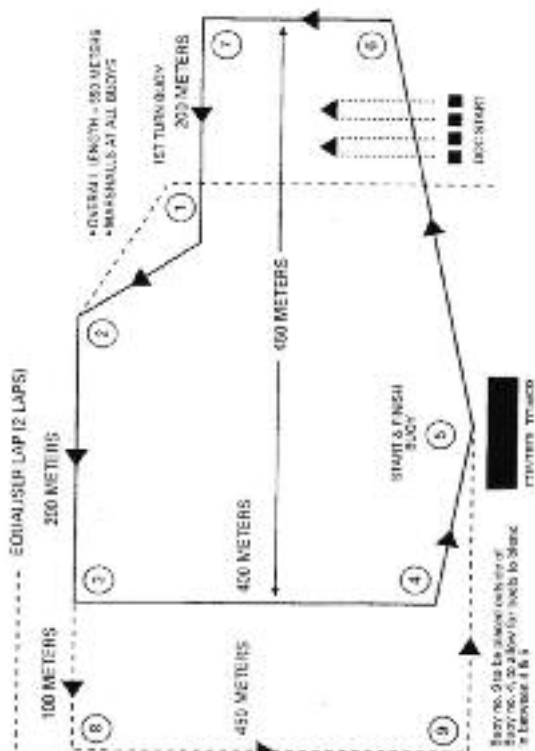
**ANNEXURE B****International CIRCUIT Course**

## **565 - RIGID INFLATABLE BOATS (PR) (PF)**

### **566 - CLASSES**

PR 550 cylinder capacity of the motor to 550 cc incl.

PR 700 cylinder capacity of the motor to 725 cc incl.

PR 750 cylinder capacity of the motor from 551 cc to 770 cc incl.

PR 850 cylinder capacity of the motor from 771 cc to 870 cc incl.

PR 1000 cylinder capacity of the motor from 871 cc to 1060 cc incl.

PR 1500 cylinder capacity of the motor from 1061 cc to 1550 cc incl.

PR 2000 cylinder capacity of the motor from 1551 cc to 2050 cc incl.

PR 3000 cylinder capacity of the motor from 2051 c to 3150 cc incl.

A free category (e.g. catamaran) is established in the following classes:

PF 550 cylinder capacity of the motor to 550 cc inclusive

PF 750 cylinder capacity of the motor from 551 cc to 750 cc incl.

PF 850 cylinder capacity of the motor from 751 cc to 870 cc incl.

### **566.01 - LOW EMISSION ENGINES**

Additional provisional classes for 2008 for low emission engines complying with 2006 EPA rules (as per homologation sheet) :

PR 30 HP Horse-power of the engine not more than 30

PR 60 HP Horse-power of the engine not more than 60

PR 115 HP Horse-power of the engine not more than 115

PR 200 HP Horse-power of the engine not more than 200

PR ∞ Horse-power of the engine - unlimited

The races in these classes are run along with conventional classes. The classification can only be established if there is a minimum of 5 entries per event per provisional class. The organizer must provide the equipment necessary to confirm the power rating of the engine in accordance with the U.I.M. / Engine manufacturer recommendations, otherwise there will be no classification in provisional classes.

## **567 - HULL (PR CLASSES ONLY)**

### **567.01**

The bottom of the hull may be convex, but not be concave.

Hull consists of rigid centre section and pneumatic tubes.

***For the Endurance Pneumatics Championships materials of the rigid centre section, keel, transom etc. are free.***

Pneumatic tubes must be inflated with atmospheric air and made with fabrics with plastometers and elastometers in two or more independent compartments.

### **567.02**

To reach the minimum weight, fixed ballast is allowed, and must be permanent rigid and fixed to the inside of the hull.

It should not exceed 10 percent of the weight of the hull without ballast.

### **567.03**

Only monohull form is permitted. The boat shall not present in any of its lines any configuration which could contribute to aerodynamic lift.

Transverse steps, tunnels, hydrofoils or devices which add air pressure under the hull, are prohibited, except that protruding strips or redans parallel to the fore and aft line of the keel are permitted providing that in any channels, etc. so produced the horizontal measurements, of

such openings with the boat on an even keel, do not add up to be a total of more than 10% of the width of the hull in any transverse section for PR 850 and below and 20 % for PR 1000 and up. This includes the tunnels of the joint between the tubes and the rigid hull for PR 850 and below.

***For circuit endurance championships transverse sections should, from centerline, have positive angles up to sections maximum beam, except in the following two cases:***

- Each spray deflector may have a concave surface with a horizontal width from the hull to the outside of the spray deflector of no more than 8 % of the hull's bottom-section-beam.***
- Each spray deflector must not have a total downward angle exceeding 20 degrees.***
- Transverse redans are permitted.***
- Steps which are swept may have a distance of no more than 25% of Measured Length of hull.***

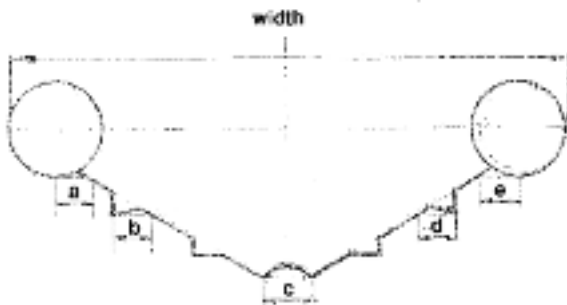

**For PR 550, 700, 750, 850 :  $a+b+c+d+e < 10\%$  of the width**  
**For PR 1000, 1500, 2000, 3000 :  $b+c+d < 20\%$  of the width**

## 567.04

Steering by a steering wheel is mandatory, the control handle for reverse gear must be within hand reach of the driver.

Kind, number and position of seats are free.

Restraint system (driver harness) is prohibited.

The use of any device or part of the boat construction, which is blocking the driver from freely getting out of his sitting position, without removing the above-mentioned device or part, is prohibited.

## 567.05

Any device to produce a sudden braking effect, causing excessive water spray, reducing visibility, is prohibited.



**567.12 - MINIMUM DIMENSIONS**

Class	Weight	Length	Width	Amidship Min. Tube Diameter
PR,PF550	200 kg	3.50 m	1.50 m	0.25 m
PR700	280 kg	3.70 m	1.60 m	0.25 m
PR,PF750	280 kg	4.00 m	1.70 m	0.30 m
PR,PF850	300 kg	4.10 m	1.80 m	0.35 m
PR1000	470 kg	4.20 m	1.80 m	0.35 m
PR1500	520 kg	5.00 m	1.80 m	0.35 m
PR2000	600 kg	5.30 m	1.80 m	0.40 m
PR3000	680 kg	5.60 m	2.00 m	0.40 m

1. The minimum weights mentioned here above are the weight of a complete rig weighed directly after the race without driver, residual water but including the residual fuel.
2. Measurements are taken while the boat is ashore.

The length must be measured as the overall length of the between perpendiculars at the foremost part of the boat including the pneumatic tubes to the utmost part of the boat.

Any extending parts, rubbing starches, fenders, stabilising and trim tabs and rudder are not to be included.

The width of the boat is measured at the widest part of the boat.

3. The tube diameter will be measured amidships of the boat. The diameter in the bow should be at least 0.25 m in classes PR700 up. PR550 class can go down to 0.20 m.

## **568 - MACHINERY**

### **568.01**

Only one propulsion motor is allowed and all of the propulsive effort shall be exerted through the water.

An outboard is a mechanical propulsion assembly which can be removed from the boat in a single unit, complete with its transmission and which does not transmit its power through the hull at any point.

The motor thus removed and placed ashore must be capable of being started and run, fed by its fuel tank.

The mounting supports fixed to the boat, the control levers, the tachometer with its connections, the battery with its conductors and the fuel tank and fuel lines do not form part of the motor unit.

The attachment angle and the height of the motor must remain fixed while the boat is under way.

For PR,PF 550 the centre of the propeller shaft (measured at the centre point of the rear end of the propeller shaft) shall not be above the bottom of the boat measured at the lowest point of the transom. This dimension will be checked in the "as raced" condition.

### **568.02**

The outboard motor must be able to function at reduced speed.

### **568.03**

When the motor is in the water, the cooling water must be fed by the water circulation pump.

### **568.04**

A gear changing system giving forward, neutral and astern movement is compulsory.

The control handle for reverse gear must be within hand reach of driver.

The casing of the underwater unit (gear case) is free. All internal parts referred to on the homologation file must be maintained. Should the homologation provide for it, the exhaust will be a propeller exhaust.

## 568.05

An electric or manual starter to assure a quick and easy start without complications must be fitted.

It must be used as it was supplied by the manufacturer.

## 568.10 - SOLE MODIFICATIONS ALLOWED

Only the following modifications are allowed:

1. All nuts, screws, washers and bolts may be replaced.
2. The original propeller may be replaced by another. Gearcases with a propeller exhaust must use propellers equipped with an exhaust tube of a diameter at least that of the machined recess into which the standard propeller boss fits at the rear of the gearcase. The length of this tube must be at least  $1/2(Q - P)$ , where Q and P are the dimensions shown on the sketch of the underwater unit on the homologation file. ***For Endurance Pneumatics Championships the original propeller may be replaced by another. Gearcases with exhaust system can use propellers not equipped with an exhaust tube.***
3. The trim tab may be altered or removed to accommodate a propeller.
4. The cooling system must be provided by the water pump.
5. Thermostats and pressure valves of the cooling system may be removed.
6. The steering mechanism may be altered. If the original steering bar is removed or new ones are installed, any openings created must be sealed to prevent the motor from pulling in additional air.

7. The dampers (shock absorbers) may be altered or removed.
8. The rubber mounts of the motor may be altered, removed or replaced.
9. Revolution counters, water temperature gauges, water pressure gauges and similar instruments, can be installed.
10. Revolution limiters may be removed.
11. The gear interlock device on the starter may be removed.
12. Spark plugs are free.
13. Original carburettor jets may be replaced for another size.
14. Springs may be added to the throttle lever of the carburettors.
15. Re-boring is allowed, but only pistons supplied by the manufacturer of the motor may be used within the cc-limit of the class.
16. A part which is dimensioned in the homologation sheet may be machined for the purpose of reaching that specific measure;
17. A part may be machined to attain the weight quoted in the homologation sheet without altering other criteria given for the part in question. It is not allowed to change the flywheel but balancing machining is allowed if the dimensions and weights provided for on the homologation sheet are respected;
18. Measurements not quoted in the homologation sheet shall only be checked by visual comparison with standard parts. As the actual manufacturing tolerances are not published, small differences between the inspected part and the reference part must be accepted.
19. No parts may be added to the motor unless specified in this rule.
20. The fuel connector in the lower cover may be removed and the fuel hose from the fuel tank connected directly to the fuel pump. If this is done the opening left after the connector and around the fuel hose must be sealed to prevent extra air entering inside the cover.

21. Electric fuel pumps may be added provided the fuel still runs through the original fuel system and no parts are removed or blocked off.
22. It is allowed to extend the starter cord of a rewind starter so that the starting handle can be reached from the cockpit/drivers position.

## **569 - FUEL**

See 508.01, 508.02, 508.06, 508.07, 508.08, 508.09, 508.10, 508.11.

## **570 - BOATS WITH DIESEL MOTORS (D)**

### **571 - CLASSES**

#### **571.01**

As far as speed competitions are concerned, U.I.M. makes no distinction between boats with gasoline or Diesel motors.

#### **571.02**

This class is not subject to any restriction as to the form of the hull, the cylinder capacity or weight, except in the “offshore” class boat q.v.

#### **571.03**

For world speed, distance and duration records, the U.I.M. recognises a single class of boats with one or more Diesel motors.

## **572 - HULL**

### **572.01**

The hull design is free.

## **573 - MACHINERY**

### **573.01**

Reverse gear is not compulsory.

### **573.02**

Any system of supercharging is allowed without penalisation.

### **573.03**

In normal running order: a diesel motor is defined as one in which the ignition of the fuel air mixture is caused only by the heat of the compression.

### **573.04**

The fuel used is injected into the combustion or pre combustion chamber, and not introduced into the inlet manifold together with the air for combustion.

### **573.05**

To start the motor, either before a race or after its stopping at a refuelling station, conditions contained in Articles 573.03 to 573.04 are not obligatory.

## **573.06**

Starting the motor must be done only under the direct supervision of the Technical Officer in order to have the conditions stipulated in rules 573.04 enforced at the start and during the whole event.

## **574 - FUEL**

See 508.04.

## **580 - TURBO JETS AND ROCKET PROPELLED BOATS (TR)**

## **581 - CLASSES**

### **581.01**

The two series are classified as follows:

250 kg 350 kg 500 kg 900 kg 1200 kg; over 1200 kg; and prototypes.

### **581.02**

These boats are not entitled to race, though they can attempt world speed records.

### **581.03**

Turbo-jet and rocket propelled boats are accepted as international series.

## **582 - HULL**

### **582.01**

The hull design is free.

### **582.02**

Weighing of the boats in running order must be made possible when a record attempt is made, by means of a balance duly certified by the appropriate Weights and Measures Authority.

### **582.03**

The boats are to be weighed without driver, residual water, but with residual fuel.

### **582.04**

Any device to produce a sudden braking effect, causing excessive water spray, reducing visibility, is prohibited.

### **582.05**

The measurer must certify that the boat as weighed is in running order, only the addition of the driver, water, oil or fuel needed to operate is allowed.

### **582.06**

A U.I.M. registered reinforced cockpit is required. Following rules are recommended: 509.02 (HANS device and seat); 509.16 (canopies); 509.20 (air supply).



## **583 - MACHINERY**

### **583.01**

A turbo-jet is a rotating motor which converts directly into mechanical work, the energy produced from an expanding fluid.

### **583.02**

A rocket is an motor which burns two fuels other than air. These two fuels are combined so as to obtain a mass of gas which is ejected at high speed.

### **583.03**

Propulsion is according to the physical law which states that action and reaction are equal and opposite.

## **584 - FUEL**

### **584.01**

The fuel is free.

## **590 - BOATS WITH AERIAL PROPELLER (A)**

## **591 - CLASSES**

### **591.01**

The boats in this series are divided into classes as follows:

250 kg - 350 kg - 500 kg - 900 kg - 1200 kg and over 1200 kg.

## **592 - HULL**

### **592.01**

The hull design is free

### **592.02**

Weighing the boats in running order must be possible at any meeting or record course, by means of a balance duly certified by the appropriate Weights and Measures Authority.

### **592.03**

The boats are to be weighed without driver, residual water, but with residual fuel.

### **592.04**

Any device to produce a sudden braking effect, causing excessive water spray, reducing visibility, is prohibited.

### **592.05**

The measurer must certify that the boat as weighed is in running order.

## **593 - MACHINERY**

### **593.01**

The machinery is free.

## **594 - FUEL**

The fuel is free.

## **595 - ELECTRIC POWERED BOATS (E)**

### **596 - CLASSES**

#### **596.01**

Battery powered 48 volt runabout

Battery powered 72 volt runabout

Battery powered 144 volt runabout

Battery powered 48 volt hydroplane

Battery powered 72 volt hydroplane

Battery powered 144 volt hydroplane

Solar powered

Hybrid battery/solar powered

#### **596.02**

Electrically propelled boats are accepted as an international series.

## **597 - HULL**

#### **597.01**

Electric powered Runabout.

Hulls are defined as a displacement type, having no steps, no breaks in the longitudinal or transverse continuity of the immersed surface other than the keel, rubbing strips or lapstrakes of no more than 18.75 mm (0.75 in) and parallel to the centreline of the boat.

Hulls are not permitted to depend on external air pressure or design which creates a tunnel effect to aid planing.

Hulls are not required to conform to any maximum or minimum dimension restrictions.

Hulls shall not have a sponson/pod protruding from the side of the boat which interrupts the line of the side non-trip or bottom of the boat.

## **597.02**

Electric hydroplane:

Hulls are unrestricted. Any boat having a multiple planing area or which cannot qualify as a runabout is considered a hydroplane.

## **597.03**

Hybrid solar/battery powered marathon boats:

The hull is free.

## **598 - MACHINERY**

### **598.01**

The whole of the propelling power shall be electric.

Excluding noted class restrictions for motors, drive train design is unrestricted.

## **598.02 - ELECTRIC RUNABOUT AND HYDROPLANE**

The whole of the electrical energy shall be battery stored and carried on board and when the boat is being timed or raced over the measured distance, no additional electric power shall be generated.

Power source for circuit racing shall be multiples of commercially available lead/acid batteries, nominally rated at 12 volts.

Motors are restricted to brush type direct current only.

## **598.03 - BATTERY POWERED MARATHON BOATS**

The whole of the electric energy shall be battery stored and carried on board and when the boat is being timed or raced over the measured distance, no additional power shall be generated.

Power source shall be multiples of commercially available lead/acid batteries, nominally rated at 12 volts.

Total battery weight shall not exceed 57 kg (125 pounds).

## **598.04 - SOLAR POWERED**

The whole of the energy required shall be from ambient solar power excluding wind. Solar collectors designed as rigid or flexible sails are not allowed.

## **598.05 - HYBRID SOLAR/BATTERY POWERED**

The whole of the propulsion energy shall be battery stored and carried on board.

Solar power may charge the batteries while the boat is being timed or raced over the measured distance.

## **599 - ELECTRIC BOAT SAFETY RULES**

### **599.01 - ELECTRIC BOATS**

Exposed terminals shall be taped over or otherwise insulated to prevent accidental short circuits.

Batteries must be securely fastened to the boat in such manner that if the boat were to capsize, the batteries would remain with the hull.

Boats must incorporate enough flotation to ensure that, in the event of accident, the boat will float enough to be salvaged.

All electric boats in competition must be equipped with a physical disconnect. The purpose of the disconnect is to stop the motor, disable the electric system and limit power to safe levels in the event of an accident.

In any boat operating at voltages above 72 volts, such disconnect must be incorporated into the power system in a manner which splits battery power into packages of 72 volts or less.

The disconnect must consist of a plug and tether combination. The plug fits an in-line receptacle completing the electrical circuit and allowing it to be energised. The tether must be two metres or less in length and made of or attached to the plug by material not subject to heat damage such as melting or becoming brittle.

All safety tethers must be securely attached to the driver at all times whilst the boat and the driver are under way.

At any time an electric boat is launched, recovered, disabled on the course or is under tow, the disconnect plug shall be removed from the in-line receptacle.

A caution decal must be affixed in the vicinity of the disconnect receptacle, and to the bottom or non-trip at the same approximate station line. Its purpose is to warn rescuers against handling the boat at that point and possibly completing the electrical circuit.

All exposed drives and drive trains must be adequately covered or shielded with appropriate guards or covers.

Commutator shielding is recommended in all electric boats.

Protective clothing must be worn by all drivers participating in electric events.

## **599.02 - ELECTRIC BOAT RACING RULES**

Starts must be dead motor starts. Drivers must draw for lane positions.

Classes and hulls shall be in conformance with class rules.

Electric boat drivers who's boats are not on plane by the time the lead boat reaches a predetermined point must move off course and stop. The shutdown point will be determined by the drivers prior to the drivers meeting. Failure of a driver complying with this rule will result in a one race suspension.

## **600 - RECORDS AND PERFORMANCES**

### **600.01 - GENERAL**

All record trials and their control are submitted to the following rules.

The record belongs personally to the driver who has established or beaten it. The record is entered under the name and nationality of the driver.

Any race against the clock, and called kilometre or mile trials or any similar name is prohibited if not conducted in accordance with these rules.

Combining speed records with distance records is not allowed.

No direct or indirect aid is to be provided to the driver who attempts a record.

### **600.02**

World speed records, hour records, distance records and competition records are all records open to all boats and aquabikes of international classes adopted by U.I.M.

### **600.03**

National records recognised by U.I.M. are the records established by boats of national classes duly recognised by the national authority (the rules of which have been approved by U.I.M.). The Certificate differs from those issued for World Records.

### **600.04**

The World's Unrestricted Water Speed Record is awarded to the fastest boat in the world piloted by a driver, irrespective of the class of boat. This record is established in conformity with U.I.M. rules, including a U.I.M.



registered reinforced cockpit. Following rules are recommended: 509.05 (Hans Device and seat); 509.16 (canopies); 509.20 (air supply).

## **600.05 - ELECTRIC BOAT RECORDS RULES**

Power source for water speed record trials shall be multiples of commercially available batteries of any type. Motors are restricted to direct current (dc) only.

Boats may be towed to an on-course starting point, but may not be towed to achieve a planing attitude. Any such assistance will result in the disqualification of the offending boat.

Once at the starting point, all tenders and assisting craft must be removed to positions away from the racing line.

Recharging or replacement of batteries between initial and return runs while attempting a record is not permitted.

## **601 - CLASSES ELIGIBLE FOR RECORDS**

### **601.01**

World records may be attempted with the following craft:

- All U.I.M. series and classes;
- American Powerboat Association classes;
- Prototypes.

### **601.02**

A boat can establish a record in its own class only.

### **601.03 - FROZEN RECORDS**

When a class is modified so as to reduce the performance of the class, for example by:

- reducing the cylinder capacity,
- restricting the tuning permitted,
- restricting fuel permitted,
- introducing a minimum weight,
- increasing the minimum weight,
- or any other means,

the records established before the modification comes into force may be frozen on the determination of the Sports Commission and a new series of records will be started.

All proposal for new rules, rule changes and U.I.M. General Assembly minutes shall state:

- whether or not records will be frozen,
- the classes to be frozen,
- the date(s) when the classes are to be frozen.

### **601.04 - QUALIFICATION**

For offshore records a boat must have completed the course, taken the chequered flag and finished first, second or third, in a U.I.M. World or U.I.M. Continental Championship race in the class to be attempted and after the date when the class was last frozen.

## **602 - DEFINITION OF UNITS**

### **602.01 - TIME, DISTANCE AND SPEEDS**

The hour is the twenty-fourth part of a terrestrial day. The symbol is letter "h".

The minute of time is the sixtieth part of one hour. The symbol is letters “mn”;

The second of time is the sixtieth part of one minute. The symbol is the letter “s”.

nautical mile	=	nm
statute mile	=	st.m
kilometre	=	km
nautical mile per hour	=	knot
statute mile per hour	=	mph
kilometre per hour	=	kmh

## **602.02 - STATUTE MILE, NAUTICAL MILE AND KILOMETRE**

The statute mile is an Anglo-Saxon measure.

The nautical mile is used at sea.

The knot is not a unit of length; it expresses the speed of one nautical mile per hour.

One statute mile (st.m)	= 5280 feet = 0,8690 nm = 1,609.3 km
One nautical mile (nm)	= 6080 feet = 1,852 km = 1,1508 st.m
One kilometre	= 3280.844 feet = 1000 metres

## **604 - BASES**

### **604.01**

Records may only be established on bases recognised by National Authorities and notified to the U.I.M. in accordance with these rules.

## **604.02**

The base is measured and certified by an official surveyor holding a certificate of competence from a recognised institute, in the presence of a delegate of the National Authority.

The base must be measured by triangulation or electronic distance measuring equipment (EDM), which must have a first class certificate delivered by an Observatory or similar authority. This certificate must not be older than two years.

The official surveyor provides a certificate in duplicate in which the strict adherence to the above requirements is certified.

The certificate is signed by the surveyor and countersigned by the delegate of the National Authority. One of the copies is for retention by the National Authority for its special national records files and the other is sent to U.I.M. for its special world record files.

The base for a record must be a fixed base, as laid out for a national authority or must be measured for a special occasion in waters designated by the driver. It must be defined by fixed marks ashore.

## **604.03**

No distinction is made between records established on the sea, rivers or lakes. Records must not be attempted during the period between half an hour before and half an hour after a change of direction in flow of water over the course (change of tidal flow).

## **604.04**

Any expenses incurred in the laying of a temporary course are defrayed by the entrant attempting the record.

## **604.05**

For speed records there shall be only one attempt on the course at anyone time.

An attempt must not start until the director of the trial is satisfied that effective rescue boats are on the course.

## **605 - CALCULATION OF SPEED**

### **605.01**

The National Authority calculates the speed from the data provided by timekeepers. The speed is to be shown in kilometres per hour (kmh) and statute miles per hour (mph), even when the attempt takes place on a course of one nautical mile;

The duration of each run is obtained by taking the arithmetical mean of the times recorded by two sets of timing devices the mean time being given to one hundredth of a second.

Should one of the timing devices stop or one of the signals fail and only one duration be registered, this duration will be accepted.

### **605.02**

The duration so obtained serve to calculate the speed of each run. Only two decimal places are to be used.

### **605.03**

The speed of the trial is the arithmetical mean of the speeds, two decimal places being used.

### **605.04**

For speed records established on a distance of one nautical mile (1nm= 1.852 km = 1.1508 st.m) the following constants are to be used:

Where t is the time in seconds.

to obtain the speed in mph:  $4141,9 \div t$

to obtain the speed in kmh:  $6667,1 \div t$

## **606 - MARGIN REQUIRED**

A record will be valid only if its speed at least equals the speed of the previous record multiplied by 1.003.

## **607 - MOTORS**

### **607.01**

All accessories and/or elements required by the racing rules for each class of boat attempting to establish or improve a record must be on board during said attempt.

### **607.02**

A boat which holds two certificates for two different classes is entitled to establish world records in those two classes, but shall make two distinct trials, one for each class.

### **607.03**

Immediately after the record trial, the motor(s) or engine(s) must be sealed with a distinctive seal in the presence of the officials who have witnessed the trial.

### **607.04**

Within 48 hours of the trial, the two measurers must check that the hulls, motors and equipment are in conformity with the specifications of their class, and this inspection must be carried out in the presence of the Officer of the Day or an Official specially appointed by the National Authority.

### **607.05**

When attempting to break a U.I.M. class record, the noise level of the motor shall not exceed the authorised level (rule. 504).

### **607.06**

It is mandatory to perform a noise measurement during record runs. The results of the measurements must be included in the signed measurers' report, sent to U.I.M.

## **608 - REQUEST TO ORGANISE**

### **608.01**

All applications for records trials must be made in writing to the National Authority at least one week before the trial and must be accompanied by the fee stipulated by the National Authority.

The National Authority applies to the U.I.M. for homologation of records.

### **608.02**

Only records established under the direct control of a National Authority affiliated to U.I.M. can be recognised.

### **608.03**

Each National Authority decides on the application for records to be established on its territory. The National Authority may refuse to consider a record application but must then explain the reasons in writing.

The National Authority indicates the validity of the record permit.

## **608.04**

It is the duty of the driver to accept responsibility for any safety measures deemed necessary for this attempt.

The officials will not accept any responsibility, they will only record the results and ensure that the rules are complied with.

## **609 - OFFICIALS**

### **609.01**

The National Authority shall appoint an Official Observer and other duly qualified persons to hold the official functions.

An official so nominated shall not hold any other office than that to which he was nominated. An official shall not himself establish a record.

### **609.02**

The official timekeepers and officials may receive payment for their services at rates fixed by the National Authority.

### **609.03**

Time keeping may only be carried out by timekeepers and officials who have been recognised and authorised by the appropriate National Authority.

The stop-watches or any other apparatus employed must have a first-class certificate delivered by an observatory or similar authority. This certificate must not be older than two years.

Each timekeeper hands to the National Authority a signed report of the record attempt, countersigned by the official observer.



## 609.04

Timing from aboard anchored boats or aboard competing boats is not allowed.

## 610 - SPEED RECORDS

### 610.01

There is only one world record per class. This record can be established over the nautical mile, land mile or the kilometre, for aquabikes the distance may be 500 metres.

### 610.02

The course is covered once in each direction consecutively.

The course is to be marked at either end by two posts in solid material, put up on shore with approved distinguishing marks affixed to them. The two lines uniting the two pairs of posts are parallel to each other and at right angles to the line of the measured course. Steering marks may be placed wherever needed.

90° 1 mile      90°

1 kilometre

1 statute mile

### 610.03

In wide rivers and lakes, the width of the course may be marked off at each end by two buoys, moored at a distance of one hundred metres from each other. The boats must run between these buoys.

## **610.04**

*Timing is to be by two photoelectric, optical scanner trigger, video or similar systems, one at each end of the timed distance that can determine the exact instant the front of the boat passes a line determined by the surveyed timing marks (610.02). The systems must be linked and trigger two timers (clocks). Timing is to be to one hundredth of a second.*

*The official record time is the average of the two timers.*

There must be a timekeeper and a timekeeper observer at each position.

The times of day of each attempt must be recorded.

The time elapsing between the two runs must not exceed 20 minutes except for jet attempts when the permitted interval is one hour.

## **610.05**

A driver may re-start an attempt because of breakdown or other reason and may stop the engine or boat between runs.

If the attempt has not been completed within four hours of a starting time fixed by the National Authority, the officer in charge may stop the trial.

## **611 - DISTANCE RECORDS**

### **611.01**

Distance records are established on a total course of twelve nautical miles for the outboard series and twenty-four nautical miles for other series, and six nautical miles for aquabikes.

### **611.02**

In distance records, the base is covered up and down successively in even numbers and the turns are not included in the distance.

The course for distance records may be:

- a course established for speed records;
- a base of three nautical miles maximum, in straight lines with buoys placed at the corners if necessary, no corner to be less than 135 degrees.

The buoys placed at the corners must always be rounded.

### **611.03**

Any base must be defined by two posts set in concrete at either end.

### **611.04**

Timing is to be to one tenth of a second.

The timing of distance records is done by a timekeeper with two timing devices at the starting line. He is assisted by two officials, one with him and one at the other end.

### **611.05**

Stopping the motor or the boat during a distance record attempt is prohibited.

## **612 - HOUR RECORDS**

### **612.01**

The following international and national records are recognised by U.I.M.: 1, 2, 3, 4, 6, 9, 12 and 24 hours duration records for all the series recognised by U.I.M.

The homologation of a record of lesser duration than that applied for may be granted, but only within such limits as provided for by the above rule.

## **612.02**

The base must not exceed six nautical mile from station to station, that is to say twelve nautical miles up and down. For aquabikes only, the distance may be 3 nautical miles from station to station that is to say 6 nautical miles up and down.

## **612.03**

The base is defined by two posts set in concrete at either end.

## **612.04**

The boat may be driven by more than one driver, but their names must be filed in the record application.

## **612.05**

Repairs and adjustments which can be carried out on board may be effected on the course.

The same motor or engine and hull must be used throughout the trial.

On the other hand, repairs that cannot be effected on board and refuelling and changing of drivers must be effected at the control station and are to be supervised by an official.

## **612.06**

Any time during which a boat stops during an attempt is included in the elapsed time for the attempt.

Turns are included in the course and are consequently not excluded from the timing.

**612.07**

Timing is carried out by one or several timekeepers with two timing devices stationed at the start. The timekeeper is assisted by two officials, one stationed with him and one stationed at the other end.

**612.08**

A driver can claim several different hour records during one trial by selecting the best series of consecutive laps.

**612.09**

The boat must cross the finishing line at the end of the lap (the last lap) during which the record time has elapsed.

The average speed of the last lap is calculated and the distance which corresponds to the time still to be run is added to the distance covered at the end of the penultimate lap.

The result is shown as the distance covered in the record time and the average speed for that distance.

**612.10**

Example for a two hour record on a base of six nautical miles (nm), twelve nautical miles per lap:

12 nautical miles (nm) x 1.1508 = 13.81 statute miles (st.m)

boat completes 8 laps in 1h 54mn 40s = 110.48 st.m

ninth lap completed in 13mn 50s = 830 s

time balance 5 mn 20s = 320 s

distance balance = 13,81 st.m: 830x320 = 5.32 st.m

Total distance in 2 h = 115.80 st.m

Average speed =  $115.80 \div 2$  = 57.90 mph

## **613 - WORLD COMPETITION RECORDS**

### **613.01**

The U.I.M. recognises world records of 3, 5, 10 and 15 statute miles in races for all U.I.M. circuit classes.

No other records may be established during a race.

Unlimited hydroplanes only are entitled to statute mile records established on:

- a single lap course (two laps for APBA Gold Cup races) while qualifying or racing,
- total heat average speed while racing.

## **614 - PERFORMANCE CERTIFICATES**

### **614.01**

U.I.M. may issue Performance Certificates for the best heats made during races for the principal international trophies.

### **614.02**

Application for these is to be made by the National Authority of the country where the race took place and the accuracy of the results, timing course and class is to be certified by them.

### **614.03**

U.I.M. only recognise the results which beat previous performances.

## **614.04**

The amount of the fee for Performance Certificate is decided upon annually by the General Assembly.

## **614.05**

U.I.M. may issue a performance Certificate for speed trials made by boats not included in U.I.M. classes. These trials must, however, be made in accordance with U.I.M. rules.

U.I.M. award Performance certificates for boats of the Production boats Series having established or broken speed, duration, distance or competition records according to the Record Rules.

## **614.06**

For these performances, it is not permissible to remove any of the boat's accessories, or items of comfort, provided by the builder and these are compulsory for racing.

U.I.M. may award Performance certificates for any of the offshore classes, international and national, established at sea on properly measured runs.

## **615 - HOMOLOGATION OF RECORDS**

### **615.01**

Only records homologated by U.I.M. are considered as World Records.

Only records established under the direct control of a National Authority affiliated to U.I.M. can be recognised.

## **615.02**

If a record has been established on the territory of two National Authorities, it will be entered as a record by the National Authority on whose territory the start was made.

As soon as a record trial has taken place, the National Authority communicate the results to the Secretary General of U.I.M. by fax and confirm it by letter.

The information has no official character and is only transmitted to such National Authorities as apply for it, in order to avoid useless trials.

## **615.04**

The timekeepers and measurers must complete the official U.I.M. record application form which must be signed as correct by O.O.D. and be sent to the National Authority within three days of the trial, seven days for APBA controlled classes.

The National Authority transmits the application for homologation, together with other necessary papers, to the U.I.M. no later than four weeks after the trial, sixteen weeks for APBA controlled classes.

## **615.05**

For a request for homologation to be considered by the U.I.M., the National Authority must send:

- a plan of the course if not already in possession of the U.I.M.,
- the completed official U.I.M. application form which must include any National Authority calculations,
- a copy of the boat's measurement certificate,
- a photograph of the boat under way with the colours, inscriptions, etc. noted on the reverse ; also to be noted on the reverse, the driver's name, class and speed achieved,
- a list of the full names of the officials with, at least, the names of the Timekeepers, Measurers, Rescue Officer, O.O.D. and Observer,



- for offshore boats, a copy of the results in which the boat qualified, as per U.I.M. rule 601.04,
- for attempts on tidal waters, the calculation stating the times of the changes of direction of water along the course (changes in tidal flow) and the source of the information,
- a cheque for the amount due

## **615.06**

The recognition fee is fixed annually by the General Assembly.

## **615.07**

Pending the official confirmation by U.I.M., neither the driver, builder nor any other shall publish or cause to be published, circulate or cause to be circulated, the results of the trial, until the delegate of the National Authority has given the actual results in writing, after checking the calculations in the presence of timekeepers.

Even when such authorisation has been received, results may only be published with the addition of the words "Subject to official certification by U.I.M." in as large and prominent type as that in which any part of the notification itself is printed.

Neglect to comply with the above regulations automatically entails the refusal to recognise the record. The National Authority have the right to penalise whoever is responsible.

## **615.08**

U.I.M. issues annually a list of world records, changes being made known, when they occur, by means of newsletters.

U.I.M. keeps a registered list of all word records and delivers a certificate for each new record.

## **700 - ENVIRONMENT**

### **701 - NOISE LEVEL**

Every driver is responsible that his engine(s) does not exceed noise levels at all times as specified in Rule 504.

#### **NOISE CONTROL**

All race and record attempt organisers are responsible that noise control rule 504 is enforced.

### **702 - EMISSIONS**

To reduce emissions as much as possible, all drivers are recommended to use lead free petrol and biodegradable lubrication oil.

### **703 - RE-FUELLING**

Every care must be taken not to spill fuel or oil. An absorbent carpet to avoid any spillage on to the ground must be used.

## **704 - ENVIRONMENTAL CARE IN RACE AREAS**

### **704.1**

Every organiser must appoint a responsible person or persons to make necessary arrangements to control the environment of the whole race area including spectator areas.

**704.2**

There must be large containers in the pits where waste, such as cans, containers, oil waste can be placed.

One person must be responsible for this and to authorise the proper removal after the race meeting with the Local Authorities.

## **800 - CUPS AND TROPHIES**

### **800.01 - INTERNATIONAL CUPS**

The National Authorities must send to the Secretary of the U.I.M. a copy of their international Cup Rules, Year Books, official Statutes and other publications. These documents will be held at the disposal of all National Authorities.

### **801 - ALFRED BUYSSE TROPHY**

The Alfred Buysse Trophy is perpetual.

The present regulations may be modified by the donor and after him by the General Assembly.

The holder of the cup must insure its safe keeping for a year and return it personally to the National Authority.

Two plaques, presented to winners, remain their property.

The Trophy goes to the driver who has the highest number of points from titled international meetings in the list established by the Sports Commission. The latter decides which of the classes entered will count for the competition.

Only the points obtained between 1<sup>st</sup> of November and 31<sup>st</sup> of October by the first five drivers of each competition and of which the results have been properly communicated to the Secretary of the U.I.M. by the National Authority are taken into consideration.

The U.I.M. Secretariat publishes the results in the first bulletin following the receipt.

The interested National Authorities must indicate at the beginning of the year, which are the meetings held in their country counting for the Buysse Trophy.

All results counting for the trophy are to be sent to the U.I.M. Secretariat within a fortnight after each race.

## **802 - JOHN WARD TROPHY**

The Trophy created in 1925 at a worth 762 €. The funds were subscribed by several welldoers and the affiliated National Authorities.

It is attributed to the 0 500 class of racing outboards but the Council has the right to attribute the Trophy to another class subject to one year's notice.

The John Ward Trophy may be raced for only by drivers holding a driver's licence issued by their National Authority.

The John Ward Trophy is raced for annually during an international titled meeting.

There is only one race for the John Ward Trophy each year.

It is not allowed to combine this race with a cup or trophy bearing another name. However, the organisers may give cups and other prizes to the competitors.

The John Ward Trophy is perpetual. The organisers hand to the winner a cup bearing the inscription "John Ward Trophy - Anno..." as a souvenir.

Because of the fragility of the Trophy, the Union has decided not to dispatch it anymore to winners.

The race is in circuit, in two heats of 9 kilometres or 5nm each. Classification on points system as per rule 318.01 of the Racing rules. In case of a dead heat, the total elapsed times decide.

The Organising Committee must transmit the results to the Secretariat of the Union, without delay.

If the National Authority who has undertaken to organise the race cannot do so, they at once notify the Secretariat of the U.I.M. who may then offer the organisation to another National Authority.

The Trophy remains the property of the U.I.M.

In case the Union is dissolved, the extraordinary General Meeting held as per statutes decides what to do with it.

Any dispute concerning the attribution of the Trophy must be placed before the U.I.M. by the National Authority. The decision of the Union is final.

The present rules can be altered only by the General Assembly of the U.I.M.

The organisation of the meeting is decided by priority of the alphabetic rotation of the affiliated nations, the French names of these nations being considered to this effect.

Should a nation decline the organisation, the nation which comes next in rotation is taken into consideration.

Should a nation enter the race on the Calendar for a given year but fail to organise it, said Nation is considered as having held the race, as far as the rotation is concerned.

The attribution of the John ward Trophy must be done under the same conditions as for the Championships.

### **803 - BOUCQUEY TROPHY**

Same rules as Buysse Trophy.

The class is 0-850cc.

### **804 - DIETER KONIG MEMORIAL**

Will be attributed to the F.500. The three first classified at the general classification will receive respectively a golden, silver and bronze medal.

### **805 - JOHN HILL MEMORIAL**

A replica of the John Hill Memorial Trophy will be attributed each year at the last European race of the F1 World Championship. The criteria to allocate the Trophy will be "sportsmanship" and the allocation will be done by the F1 Committee. The original Trophy is kept at the U.I.M. office.

## **900 - U.I.M. RULES FOR RIVER MARATHON RACING**

### **900.1 - GENERAL**

1. River Marathon Race is a one day for classes: P and PR or a multiple day motor boat Race covering a predetermined distance per day with an overnight stop(s) at a designated area for refueling, repairs and rest if needed. The winner **will be** the boat which **takes** the least elapsed time in covering the total **pre-established** distance. There will be an Overall Winner (first, second and third places), they will be the boats which start and finish all of the legs, under their own power, and they do it in the least amount of time, regardless of their class (the boat and/or the driver must not be changed).
2. International racing is open to the classes mentioned in Rule 900.15. Titles shall be given to these classes only. Other local classes can be invited by the National Authorities and or the organizers of River Marathon Races, if so, the classes and the capacity of the engines must be indicated in the Advance Program.
3. An entry fee may be set for all classes including those which may have been given a U.I.M. international Title and must be indicated in the Advance Program.
4. An Advance Programme must be sent by the organisers of an international River Marathon Race to other National Authorities and to the U.I.M. Office at least 90 days before the race.

### **900.2 - APPLICABLE RULES**

1. River Marathon Racing is governed by these rules and by U.I.M. Circuit rule Groups 100, 200, 400.
2. In cases where these rules and the rules contained in the Circuit rule Groups are in conflict, these River Marathon rules will prevail.
3. Organisers of international races may prescribe deviations from the U.I.M. Group 100, 200 and 400 rules only when they are called for by

national legislation or by safety or environmental requirements, or when the organisers deem those rules unsuitable for River Marathon Racing in general. Such deviations can, however, be applied only if they have been published in the Advance Programme.

### **900.3 - RACE COURSE**

1. The length of the race course must be such that it can be covered in a maximum of six days of racing, excluding possible lay days which can only be a maximum of 50% of the racing days. The minimum duration of a race is two days (for inflatable boats - one day as per rule 900.1), excluding a possible lay-day.
2. A day's race course can consist of more than one leg and it can be done in the same or different rivers. The organizers must allow sufficient time between each leg for the racers to get to the finish line, it should be proportional to the length of the leg. The time allowed must be indicated in the Advance Program and must be confirmed at the driver's briefing of each particular day and/or leg. If the race course is divided into two **or more** legs, the distance to be raced each **day** must be such that it can be covered between official sunrise and sunset of the region in question.
3. The race course does not need to be registered or officially measured by the U.I.M.
4. A River Race can only be done on a rivers class I, II and III. Conditions on a river may vary from time to time during the year. In the Advance Program it must be indicated the class of the river for each of the legs of the race.
5. The Race Committee can postpone a day's race for 24 hours, if the weather conditions and / or river conditions are not adequate. ***They will have to follow procedures indicated in Rule 309.01 and 309.02.***



## 900.4 - CREW

1. Any race boat crew shall be comprised of no less than 2 members, one of them must be designated as the driver in the entry form.

The boat driver must be in possession of a current racing license issued by his National Authority.

2. All crew members full names, **age** and home address must be communicated to the race organisers when the boats official entry to the race is made.
3. Changes of the crew members during the race shall **only** be made with the explicit consent of the Race Committee except for the driver, **who cannot be changed**.
4. Each crew shall have one crew member designated as Captain who is responsible for the boat and all actions of its crew. All matters related to the race shall be conducted through the Captain.
5. The minimum age of a crew member is 18 years, for younger crew-members (16years or older), they can race only with a written authorization from their parents **and/or guardians**.

## 900.5 - EQUIPMENT

In order to race, each race boat must be equipped with the following:

- a) A minimum of two oars or paddles
- b) A minimum of two ropes, one measuring 12 mm (1/2 inches) in diameter and 10 m (33 ft) in length to be used for towing, another rope measuring at least 10 mm (3/8 inches) in diameter and 15 m (50 ft) in length, it must have at one end a flotation device and the other end must be fastened to the structure of the racing boat.
- c) A set of flags: red and yellow, measuring each one at least 400 x 600 mm (16 x 24 inches) and attached to a pole 800 mm (31 inches) long.
- d) An emergency first aid kit
- e) A repair kit with necessary tools

- f) Two readily accessible fire extinguishers (BC or equivalent rating) well secured to the boat having a minimum capacity each of 2.00 kg. (5 lb.). It is recommended to use a permanent fire extinguisher system with the fire trigger button within the reach of the racing crew. All the fire extinguishers must have a standard approval label and/or certificate showing that it has been serviced within the last 12 months.
- g) Life jackets for all crew members conforming to minimum specifications as stipulated in Rule 205.06.
- h) Crash helmets conforming to rule 205.07, for all crew members.
- i) Clothing of any flammable material such as plastic or nylon, can be worn by crew members on top of the racing suit only in weather affected areas. The racing suit can be a one or two piece suit, it should be made of wool or cotton, any flame retardant material is highly recommended. Regular length pants and long sleeves are required.
- j) The use of helmet to life jacket back or side straps **and / or Hans Device** are highly recommended.
- k) The crew must wear eye protection during the race, it is recommended that it is in the form of shatter proof material (plastic goggles or it could be a full face protection).
- l) The use of closed fire masks (balaclavas) by the race crew is not recommended.
- m) It is recommended that any large items liable to move in a case of an impact, must be installed and/or fastened in a manner were they will not be projected to the crew and should be fastened in such a way that they can be taken in case of an emergency.
- n) ***The use of rear view mirrors are highly recommended.***

## 900.6 - TECHNICAL SAFETY REGULATIONS

1. Fuel tanks must conform to the following when applicable:

- a) Removable fuel tanks such as those used for outboards must have quick disconnect couplers to permit such tanks to be filled at a remote location, away from the boat
  - b) a fuel tank must be properly grounded. It must have a minimum 50 mm (2 inch) diameter spout to fit the fuel tender. The spout must be fixed to the boat.
  - c) fixed fuel tanks must be properly vented to the outside of the boat
  - d) all fuel tanks must be securely fastened.
2. Any water outlets exiting from the side of the boat must be directed horizontally or downward.
  3. All propeller driven race boats must be equipped with a kill switch to stop the engine if the driver is separated from the boat.
  4. For totally enclosed inboard engines the bilge must contain a blower or must be well ventilated.
  5. It is recommended that all carburetors or induction inlets have flame arrestors, they should stay on the engine at all times when the engine is running.
  6. All moving mechanical parts such as drive shafts, flywheels, belts, pulleys, etc., have a secure cover.
  7. All Inboard engine boats and Outboard engine boats, must have a battery isolator switch. The switch should be accessible to the racing crew and must be marked by a red triangle 75mm (3 inches) sides.
  8. There should not be any sharp elements or protruding elements in the boat were the crew is seating while racing the boat, as stipulated in Rule 509.09
  9. It is recommended that the steering cables must be made of flexible stainless steel wire with a minimum diameter of 4.7 mm (3/16"). It is also recommended that the cables run from the steering wheel to the back through the middle of the race hull, in a manner to avoid hitting the race crew if they are pulled to the back.

## 900.7 - INSPECTION PROCEDURES

1. Motors, hulls and compulsory equipment subject to these rules shall be inspected prior to racing and after any of the legs have been finished to assure compliance with these rules. The technical inspection shall be conducted by designated inspectors who must report compliance or non-compliance with these rules.
2. The engine block may be given a unique identification mark to facilitate enforcement of Rule 900.8.13.
3. Each race boat and support boat, must go through a technical and safety inspection before the race. All equipment shall be available for inspection during the time and at the location specified for technical inspection. If any equipment is found not to be in compliance with these rules, or if the captain or driver has failed to comply with the spirit or letter of these rules, the Race Committee may rescind the entry. Correction or substitution may be permitted if made prior to the start of the race. The start of the race shall not be delayed to allow compliance.
4. Immediately after crossing the finish line of the last leg of the race, contestants shall report with their boats and motors to the inspector at the location designated by the Race Committee. The boats and motors shall remain in the custody of the inspector(s) until dismissed. Any contestant(s) refusing to comply with the orders of the Chief Inspector or who violates the provisions of this rule may be disqualified **from the race** by the Race Committee.
5. The Chief Inspector shall have the power, after the finish of the race, to order any contestant(s) to dismantle the motor for inspection **and**/ or measurement at the designated area. The Chief Inspector measures the engine capacity with a meter and/or gauge (if available), if the motor's capacity is on the upper limit, it will be **at** his discretion if the motor should or should not be dismantled. The cost of dismantling and assembling the motor should be paid by the contestant.

6. Any boat which after it has been inspected and according to its motor capacity should have raced in a bigger class, will be disqualified from the race by the Race Committee.
7. After an accident all boats must be inspected and released by the Technical Official of the race.  
If a boat is not released it cannot continue to race.

## 900.8 - GENERAL RACING RULES

### 1. Definitions:

- a) Race Course: **are** those rivers **and/or** waters, **and/or** segments thereof, between the first starting line and the last finish line as designated by the Race Committee
- b) Leg: that segment of the race course between the starting line and finish line as designated for any particular part of the race.
- c) Starting Line: **it is an** imaginary band, approximately one meter (three feet) in width, as drawn from the starting flag person to a point across the river or water as described by the Race Director at the daily drivers meeting
  - (1) To be ahead of the starting line implies being on the leg between the starting and finish lines so designated for that leg
  - (2) To be behind the starting line implies being out of the leg designated for that day.
- d) Staging area: that segment of the water immediately behind the starting line and continuing away from the starting line **should be of** a distance of approximately **70 meters**.
- e) Holding area: that area behind the staging area and continuing for a reasonable distance away from the staging area.
- f) Finish line: the imaginary band, approximately one meter (three feet) in width, drawn from the finish flag person to a point across and approximately perpendicular to the bank of the water. The finish line will be described at the drivers' meeting prior to the beginning of each leg.

- g) Under its own power: The boat is in motion and not assisted by any other powered vehicle or craft. When starting a leg it can not be done by the motion generated from the water current and/or the rowing action of the crew. On finishing a leg it can be done by motion generated from the water current and / or the rowing action of the crew considering that the boat has run all of the leg without any external assistance. This rule can not be changed in the Advance Program.
  - h) Under the control of its own crew: The crew is deemed to be able to control the destiny of its own boat.
  - i) Wilfully: a boat is under its own power and under the control of its crew.
  - j) Being in tow (taking a tow): the boat is put into, or is in motion with the assistance (in any way) of, another powered vehicle or craft.
  - k) Allowed starting period: that period of time between a boat's designated starting time and the official closing of the starting line.
  - l) Pit area: that area of the parking lot designated by the Race Committee for parking of racing boats, trailers and support vehicles. Each entrant will have a designated parking space for one boat and trailer in addition to an adjacent space for a support vehicle. Also, any area where boats are parked between legs of the race will be considered a pit area.
  - m) Long block: the engine block, heads, valve train, crankshaft, rods, pistons, camshaft, and timing drive assembly.
2. A Drivers' Meeting will be held prior to each leg of the race at the **indicated** time. It is compulsory that the driver of each boat entered in the next leg attend the Drivers' Meeting. A roll call will be held and a 15 minute penalty assessed for drivers being absent when their name is called.
3. The life jacket and helmet must be worn by everyone in a race boat at all time while the boat is in motion under its own power, this implies during racing, testing or tuning. Violation of this rule will result in assessment of a 15 minute penalty.

4. Drinking alcoholic beverages or using intoxicating drugs by any **race boat or safety boat drivers** or race official prior **and during the event hours** is strictly prohibited. No boat (race or safety) driver shall **drive** a boat if alcoholic beverages or intoxicating drugs have been consumed. Violation of this rule will result in total disqualification **for the drivers** or suspension of official duties **for the race official**.
5. The use of offensive language by a crew member towards any other person or crew member or race officials will not be tolerated. Violation of this rule will result in assessment of a minimum ten minute penalty.
6. Intentionally causing damage to another boat or intentionally causing bodily harm to a crew member of another boat will not be tolerated. Anyone failing to comply with this rule will be totally disqualified.
7. A crew member must obey the instructions of any Race official. Failure to do so will result up to total disqualification from the race.
8. The possession of firearms at any time during the event by any crew member is strictly prohibited. Violation of this rule will result in total disqualification.
9. No person shall provide or receive assistance from the air or by radio during the race. Failure to observe this rule will result in the contestant being disqualified for the leg. Global Positioning Systems (GPS) are allowed.
10. After the boat has passed inspection, the Race Committee may re-inspect it to insure that all of its compulsory equipment is present and technical specifications are in compliance with the rules.
11. Smoking is prohibited in the designated pit area and / or onboard a boat and / or in an area 3 m (15 ft ) around the boat. Violation of this rule by any crew or member of the team will result in a penalty to the race boat. This penalty will be assessed by the race officials and can be of 15 minutes to disqualification of one particular leg.
12. The hull shall not be replaced during the race. Failure to abide by this rule will result in total disqualification from the race.

13. **ENGINE REPLACEMENT** The organiser can decide to use Rule A or Rule B provided it is printed in the Advance Programme.

RULE A The engine block must not be changed during the race.

RULE B The complete engine can be changed once only during the race in the case of failure, provided the captain of the boat notifies the chief inspector who must authorize the change and inspect the engine to be replaced as well as the second one, for class homologation and give new identification numbers and / or marks. The second engine block cannot be replaced during the rest of the race. The Race Organizer may assess a penalty of up to 15 minutes for the engine change, this must be indicated in the Advance Program.

The initial engine block cannot be rebuilt and used for the remainder of the race.

Failure to observe any part of this rule will result in total disqualification from the race.

***If there is no indication on the Advance Program regarding the change of engines,*** then rule A will apply.

14. A boat which has been disqualified for a leg, may continue in the race, for the disqualified leg it will have the same time as the boats which did not start (DNS) Rule 900.10.13.
15. The organizers must specify in the Advance Program if there will be fuel available for the race and if the fuel for the first leg is included, what type and / or quality of fuel and under what terms and conditions it will be supplied to the racing boats.
16. Fuel can be inspected by the Chief Inspector at any time during the race, this will be done according to the regulations and procedures indicated in Rule 508. Failure to let the fuel be inspected will result in total disqualification from the race. Regular Pump fuel refers to the fuel which anyone can buy on a regular basis in any fuel station at the race site, the octanage considered for the race, will be the highest available at these stations.



17. The race boat must have a set of race numbers on each side and one on the bow of the boat. The racing numbers size on the boat must comply with Rule 206.02. The colors can be according to this rule or they can be of another color with a contrasting surface surrounding them, or they could have an outline of at least 4 cm wide of a contrasting color.
18. Any issue not foreseen by these rules will be decided by the Race Committee, according to Rule 200.02.

## **900.9 - FLAG SIGNALS**

- 1) Red Flag: raised and displayed by a safety boat or a race boat implies danger or emergency. All approaching boats must stop. It is the responsibility of a member of the safety boat, or race boat crew member if a safety boat is not present, to maintain a record of the time the boat is stopped. After stopping for a red flag, a race boat may not continue with the race until a safety boat has arrived and granted permission to continue the race even if the red flag was unjustly raised. Prior to granting permission to continue, the safety boat must record all boats' times out and forward them to the finish line officials for the leg. If a boat fails to wait for a safety boat before proceeding with the race, the time out will not be acknowledged. The boat which makes improper use of the red flag, will be disqualified from the race by the Race Committee.
- 2) Yellow Flag: A safety boat member or race boat crew may raise its yellow flag only when they have a problem, when one of the crew is in the water, or they become an obstacle in the race course and the boat prevents or endangers the safe passage of oncoming boats or endangers the life of any or all the crew members. When a yellow flag is displayed the approaching boats should proceed with caution until they pass the problem area. The improper use of the flag will result in total disqualification of the offending boat for the leg.
- 3) Black Flag: do not leave the pit area - return to the pit area.
- 4) Green Flag: It will be raised for each boat at the starting line, 10 seconds before the starting time and lowered at the starting time. It

will be raised again 10 seconds before the starting time of the following boat.

- 5) White Flag: It will be raised at the starting line, 1 (one) minute before the starting time of the first race boat of that leg and lowered 10 seconds before the starting time. For the following boats the green flag will be raised according to rule 900.9.5.
- 6) Black and White Chequered Flag: raised with the arrival of a boat at the finish line and lowered when the boat crosses the finish line.

## **900.10 - STARTING**

1. A ramp official will be present at the launching site, prior to the start of the race, to assure orderly and timely launching. Each boat may be given a launch time, each boat will have five minutes to clear the ramp / launch area. Failure to do so will result in a penalty of 15 minutes. Emergency situations requiring longer times will not be subject to the penalty at the discretion of the ramp official.
2. The starting order for other than mass starts, shall be determined by drawing lots. Subsequent starting orders for other than mass starts will be determined from the cumulative elapsed times for previous legs. The starting order will progress from the fastest time to the slowest time. The starting line officials may, at their discretion, alter the order of the start if conditions so warrant. At the starting line the numbers of the next boat to start should be displayed to the racers, the size of the numbers should be at least of 300 mm (12 inches) high and they must be black on a white surface.
3. A leg is deemed to be open to racing on completion of the drivers meeting. Thereafter, and until the leg is officially closed as per Rule 900.13.3, the leg is deemed to be open to racing.
4. All boats must be in the water and behind the starting line when a leg opens to racing. Any boat which is in the water and ahead of the starting line at this time will be deemed to be wrongfully on the leg and can be assessed a penalty of 3 minutes. In order to get behind the starting line without incurring in this penalty, such boat must proceed in accordance with Rule 900.10.12.

5. *Reserve number*
6. While the leg is open **for** racing, if for reasons beyond the control of the crew, a boat crossed the starting line, prior to its designated starting time, it will be wrongfully on the leg, the crew must raise the yellow flag, if not it will be assessed a penalty of 2 minutes. When possible the boat will have to return behind the starting line in accordance with Rule 900.10.12, in order to take his start.
7. A boat is deemed to have started a leg if it wilfully crosses the starting line from the staging area at any time after the ten (10) second flag (for its designated start) is raised and before the starting line is closed.
8. A boat will be assessed a penalty of 1 minute per second if it wilfully crosses the starting line from the staging area prior to its designated starting time.
9. If for any reason a boat will fully start on any previous minute, he will be assessed a penalty of 10 minutes per every minute that he advanced his start. In this case Rule 900.10.7 would also apply for the minute which the boat started in. For the time of the race leg, the jury will deduct the total amount of minutes which he advance his time and will add the corresponding time penalties.
10. Regardless of when a boat starts a leg, it will begin to accumulate a running time for that leg from the time that it was designated to start.
11. A boat that is unable to start at its designated starting time may remain in the staging area provided that it does not wilfully obstruct or impede a boat that is rightfully in the staging area. Failure to abide by this rule will result in assessment of a penalty of 15 minutes up to disqualification for the leg.
12. The boat that is unable to start at its designated starting time may cross the starting line from the staging area at any time within the allowed starting period provided that the ten second (green) flag has not been raised for another boat. Failure to abide by this rule will result in the assessment of a penalty of **10** minutes.

13. In order to return, or get behind the starting line when the starting line is officially open, a boat, wrongfully on a leg, must comply with the following procedures whenever applicable.
  - (a) If a boat is out of sight of the starting line, it may proceed with precaution at a reasonable speed and by no means at full speed against the direction of the race, navigating in the middle of the channel, this boat must display the yellow flag at all time. Failure to comply with this regulation will result in the assessment of a penalty of 15 minutes up to disqualification for the leg.
  - (b) If a boat is within sight of the staging area, it may proceed against the direction of the race (**not a full speed**) only when another boat is not rightfully on the segment of the leg in the direction of the staging area, the returning boat must display the yellow flag at all time. Failure to comply with this regulation will result in the assessment of a penalty of 15 minutes up to disqualification for the leg.
  - (c) A boat may enter, or pass through, the staging area from ahead of the starting line only without obstruction or impeding a boat that is rightfully in the staging area and only when the ten (10) second flag is not raised. In the event of a mass start, a boat may enter, or pass through the staging area from ahead of the starting line only when there are no other boats rightfully in the staging area. Failure to comply with this rule may result in assessment of a penalty of 15 minutes up to disqualification for the leg.
14. A boat which is unable to start a leg including the last one (DNS) may continue to compete in subsequent legs. It shall be given a time for the unstarted leg equal to the slowest boat time which finished within the allowed time of his class for that leg, plus the time penalties according to the table in Rule 900.12.8. This rule can not be changed in the Advance Program.

## 900.11 - RACE IN PROGRESS RULES

1. Any boat that is overtaking another boat must do so in a safe and courteous manner. Maintaining when possible a safe distance between the boats.

2. Any boat that is being overtaken must give way and let the faster boat through no later than the point at which the overtaking boat is within the peripheral vision of the driver. Encumbering a faster boat is not permitted and doing so will result in the assessment of a penalty of 15 minutes up to disqualification from the race.
3. Any boat that willfully travels against the direction of the race after it has started, must do so according to Rule 900.10.13.
4. The loss of any equipment required in Rule 900.5 during a race must be reported to a finish line official for that leg, **if not**, a penalty of 5 minutes will be assessed.
5. A race boat might or might not be permitted to refuel on a leg which is open to racing. This should be indicated in the Advance Program, if it is not indicated, the race boats will not be permitted to refuel.
6. The crew of the boat must remain in their seats at all times during the race. It is not allowed for any member of the crew of the boat to ride on the bow of the boat at any time during the race. Failure to abide by this rule will result in assessment of a penalty of 15 minutes.
7. If a boat is either returning to the starting line area or going to the finish line it must proceed with caution and according to Rule 900.10.13, if during the process they come to a point where the racing channel is narrow, they must stop and keep clear of the racing line to allow the coming race boats to go through and to follow the race officials instructions if any at the site.
8. If a race leg is cancelled for any reason due to the actions of a racer and / or race boat, the offending race boat will receive a time penalty of **20** minutes.

## 900.12 - FINISHING RULES

For the purpose of the Rules 900.12, the winner **of a race class** is the race boat which finishes a leg under its own power in the least amount of time.

1. A boat must cross the finish line under its own power. All the boats of a class which cross the finish line within the allowed time frame for the leg will receive their actual time. The boats of a class which cross the finish line, after it has been officially closed, shall be given a time for the leg equal to the slowest boat time of his class which finished within the allowed time for that leg, plus the time penalties according to the adjustment factors indicated in Rule 900.12.8. This will include the DNF boats Rule 900.12.4. This rule can not be changed in the Advance Program.
2. Once a boat has crossed the finish line, it may not re-enter an open leg, unless it is approved by race officials and it may only re-enter in order to get to the boat ramp. It will have to do it with precaution and displaying the yellow flag. By no means **it should** cross the river if a racing boat is approaching the finish line. Failure to comply with this regulation will result in the assessment of a penalty of 15 minutes up to disqualification for the leg.
3. The leg's starting line and finish line for each class will be closed at the time indicated at the Driver's Meeting of that day, there will be a maximum of two hours allowed after the winner of a class arrives for them to be closed. If there are two or more legs which are run in a day, the closing times will be given at the previous Driver's Meeting(s), the closing time should be calculated on the average boat speeds and leg length (it is recommended to add a 50 % of the determined time). All the boats which cross the finish line after it has been officially closed will be given a time for that leg equal to the slowest boat time of his class which finished within the allowed time for that leg plus the time penalties according to the adjustment factors indicated in Rule 900.12.8, no matter how they got to the finish line by water or land. For the last leg if a boat has started the leg and was not able to finish within the time frame indicated in this rule it shall be given a time for the leg equal to the slowest boat time of his class plus the time penalties according to the adjustment factors indicated in Rule 900.12.8.  
This rule cannot be changed in the Advance Program
4. A boat which is unable to finish a leg (DNF) may continue to compete in subsequent legs, this boat must have started the leg under its own

power and must have run at least 2 km (1.2 mi). It shall be given a time for the unfinished leg equal to the time of the slowest boat of his class which finished within the allowed time for that leg, plus the time penalties according to the adjustment factors in Rule 900.12.9. If a boat arrives to the finish line after it has been officially closed Rule 900.12.3 will apply. This rule cannot be changed in the Advance Program.

5. Official results will be determined by total elapsed time plus any time penalties incurred. They must be posted at the site and before the next day driver's meeting.
6. Immediately after finishing a leg, the crew of the boat which has been picked for inspection should make his boat available to the Chief Inspector at the designated area and will be under the Inspectors custody until inspected. Failure to comply with this regulation will result in the disqualification for the leg.
7. If during the technical inspection of the FX Class engine (tear down), the Chief Inspector determines that the motor is out of the specifications, the engine will be confiscated by the Race Organizer who will have to sell it at the race site, before the event is over. The proceeds of the sale will have to be donated to a charitable cause of the city where the race inspection was done, the receipt from the charitable group will be given to the previous owner of the engine.
8. If for any reason in one of the classes non of the boats finishes, the leg's finish line time for that class will be the time of the winner of the next smaller class plus 20 %. If there are no other classes to get this time from, the Finish Line Officials and the Chief Scorer will determine an Estimated Time, based on the distance of that particular leg at an average speed of that class, in this case for the boats which did not finish (DNF) this leg, they will have the Estimated Time plus the time penalties according to the adjustment factors in Rule 900.12.8, for the boats which did not start (DNS) this leg, they will have the Estimated Time plus the time penalties according to the adjustment factors in Rule 900.12.8. This rule can not be changed in the Advance Program.

9. The time which will be given to the boats which do not start (DNS) or to the boats which finish after the finish line is closed or the ones which start and not finish (DNF), will be **the** time of the slowest boat of **their** class for that leg which finished within the allowed time, plus the time penalties calculated based on the following :

#### ADJUSTMENT FACTORS

DNF    DNS

1.10    1.30

#### PROCEDURE

To calculate the time penalties for a particular boat which did not start (DNS) or a boat which did not finish (DNF) will be the following: The time of the slowest boat of the class which finished within the allowed time for that particular leg must be multiplied by the corresponding factor.

### 900.13 - SUPPORT BOATS

1. The race committee shall provide sufficient boats to act as safety boats at critical locations along the race course. The safety boats shall be properly equipped to provide rescue and emergency first aid services. They will be subject to inspection by the **Technical Inspector**. All occupants in safety boats shall wear nationally approved type life jackets. The safety boat captain will be a Race Official. The safety boat captain and his crew must abide by the orders of the Safety Director.
2. The safety boats are not towing crafts, however, at the boat captain's discretion, he may provide a tow after the leg is closed to the racing boats, to the nearest boat ramp or either the starting or finishing lines.
3. The Race Committee shall provide a sweep boat which will have a Race Official on board. The sweep boat will be the last official boat to leave when the starting line is officially closed. The sweep boat captain will give directions to any race boats on the leg that are unable to continue under their own power.



4. The finish line will remain open until the sweep boat has crossed. Any race boat crossing the finish line after the sweep boat, and consequently after the leg has closed, will receive ***the time as if did not finish the leg DNF Rule 900.12.4 would apply.***
5. The sweep boat shall be clearly identifiable.
6. The support boats of any of the race boats must pass a safety inspection as per Rule 900.7.3.

## **900.14 - RACE OFFICIALS**

Any Race Official may bring forth any infraction of these rules to the Race Director, the Race Official are:

- (a) Race Director
- (b) Safety Director
- (c) Safety Boat Captains
- (d) Chief Inspector
- (e) Chief Scorer
- (f) Starting Line Officials
- (g) Finish Line Officials
- (h) Ramp Officials

## **900.15 - INTERNATIONAL RACING CLASSES**

1. Series: There should be a minimum of three boats registered per class, if there are less they will move up to the next available class.
  - A) Serie Inboard Boats, (I); classes D, C, FX, B, A, and Unlimited
  - B) Serie Outboard Boats (O); classes 2000 and 3000
  - C) Serie Inflatable Boats ( P); classes 550V, 550, 850V and 850

- D) Series Rigid Inflatable Boats ( PR); classes 700, 750, 1000, 1500, 2000 and 3000

## 2. Inboard Engine Boat Classes:

Classes of Inboard Racing Boats: are determined solely on cubic capacity of the engine used and are distinguished as follows:

Hull: The hull design is free.

Length of the Hull: The minimum dimensions are 3.96 m (13 ft).

Roll Bar: Any boat must have a well structured steel chrome moly or aluminium roll bar. The minimum specifications for the chrome moly roll bar are: 3.81 cm 1 1/2 "in diameter with a wall thickness of 0.065", for the aluminium roll bar are : 3.16 cm (1 5/8 ") in diameter with a wall thickness of 3.80 mm (0.15") or a 5.0 cm (2") in diameter with a wall thickness of 3.80 mm (1 5/8"). It is also recommended that the main "A" frame(s) be made of one piece and the structure of the roll bar be done with a set of triangles with front and back supports. It is also recommended that the elements of the roll bar be secured to the chines. If possible the seats and seatbelts should be attached to the roll bar cage structure. For the existing fiber glass boats it is recommended that a roll cage or a reinforced cockpit be put in. The roll bar must be at least 100 mm (4") away from any side of the helmet of the racing crew when seated foam material can be used to cover this space, as stipulated in Rule 509.05.

Seats: There should be a high back seat for each member of the racing crew, securely attached to the hull. The back of the seat should support the back of the helmet.

Seat Belts: The crew of any racing boat with a roll bar, must be strapped to the seat with four point seat belts system, at all time during the race, the straps should have a minimum width of 50.8 mm (2"). Two seat belts straps should run over the waist at the height of the hips and the other two straps should run over the shoulders. It is recommended that the wear of the straps should be checked periodically.

Engine Mounts: The engine on classes E and above must be attached to the hull, at least on four points, unless the set up of the jet and the engine allows it to only be attached in three points closed coupled. A safety

device must be installed to the engine to avoid its forward movement in a case of a front collision.

Throttle: The throttle pedal should be attached to the hull and should be spring loaded, so it is capable of returning to the idle position.

Flotation: Its is recommended to put in the bow of the hull sufficient flotation material that would allow the recovery of the boat.

The engines on these class boats should be inboard, for each class there is a specific engine capacity range. All the boat must run with a propulsion of a jet pump and must not have any exposed propellers.

Classes	Capacity
D	3401 to 4200 cc
FX	Up to <b>5740</b> cc
C	4201 to 5100 cc
B	5101 to 6000 cc
A	6001 to 7700 cc
Unlimited	Above 7701 cc

Overall Any of the above

Multiplication Factors:

- Forced Induction engines or those engines using combustion supporting additives (e.g. nitrous oxide, turbo charged, etc.), will be required to multiply their engine capacity by 1.8 to obtain their racing class.
- Rotary Engines will be required to multiply their engine capacity by 1.8 and if forced induction is utilized a further 1.4 to obtain their racing class.
- Diesel engines are not subject to any multiplication factors to obtain their racing class irrespective of whether forced induction is utilized.

- d. Turbine engines boats are allowed, any boat with one will run in the Unlimited class.
- e. Two cycle engine boats will be required to multiply their engine capacity by 1.4 to obtain their racing class.

Exhaust: the use of an efficient manufacturer brand muffler is recommended. It will be compulsory that all boats have one at all times during practice and during the race, if the local authorities require so, this must be indicated in the advance program.

For the "FX Class" the engines allowed to race are Small Block Chevrolet (FX 1-49 series numbers) or equivalent. The race boats must be within the following specifications :

Hull : Any type of hull design and material.

Length of the Hull : The minimum dimensions are 3.96 m (13 ft).

Roll Bar : Well braced and mounted steel tube (chrome moly or aluminium tube can also be used with the minimum diameters and structure indicated previously in this rule).

Engine Type : 8 Cylinder, normally aspirated.

Engine : Chevrolet ZZ4 Crate Engine (part number 24502609) with a maximum displacement of **5400** cc.

Cylinder Bore : **No overbore is allowed.**

Cylinder Heads : **Stock GM ZZ4 cast aluminium**, no after market cylinder heads are allowed. No **polishing and/or** port work of any kind is allowed.

Oil pump : no dry sump or vacuum pumps are allowed.

Oil Pan and Valve Covers : Any type.

Ignition / Distributor : Any type.

Intake Manifold : No port matching on the intake manifold is allowed.

Carburetor : Any commercial style (or stock off the shelf), not exceeding 750 CFM.

Exhaust system : Any type.

Fuel : Any type

Propulsion : Any type of jet drive, it can be modified.

### 3. Outboard Engine Boats Classes

Classes of Outboard Racing Boats: are determined solely on cubic capacity of the engine used and are distinguished as follows:

Hull: The hull design for classes O 2000 and class O 3000 is open, there is no restriction.

Length of the Hull: The minimum dimension are 5.10 m (16 ft 9 in).

Racing Capsules: are not permitted

Roll Bar: Any aluminum boat must have a well structured steel chrome moly or aluminium roll bar. The minimum specifications for the chrome moly roll bar are : 3.81 cm (1 ½") in diameter with a wall thickness of 1.65 mm (0.065"), for the aluminium roll bar are : 3.16 cm (1 5/8") in diameter with a wall thickness of 3.00 mm (0.12"). It is also recommended that the main "A" frame(s) be made of one piece and the structure of the roll bar be done with a set of triangles with front and back supports. It is also recommended that the elements of the roll bar be secured to the chines. If possible the seats and seatbelts should be attached to the roll bar cage structure. For the existing fiber glass boats it is recommended that a roll cage or a reinforced cockpit be put in, as of 2008 it will be compulsory that all fiber glass boats have one. The roll bar must be at least 100 mm (4") away from any side of the helmet of the racing crew when seated foam material can be used to cover this space, as stipulated in Rule 509.05.

Seats: There should be a high back seat for each member of the racing crew, securely attached to the hull. The back of the seat should support the back of the helmet.

Seat Belts: The crew of any racing boat with a roll bar, must be strapped to the seat with four point seat belt system, at all time during the race, the straps should have a minimum width of 50.8 mm (2"). Two seat belts

straps should run over the waist at the height of the hips and the other two straps should run over the shoulders. It is recommended that the wear of the straps should be checked periodically.

Engine Mounts: The engine must be attached to the transom of the hull, at least in four points.

Engine Cover: All engines must run with their cover on.

Transmission: The transmission used is free

Throttle: The throttle pedal should be attached to the hull and should be spring loaded, so it is capable of returning to the idle position.

Flotation: Its is recommended to put in the bow of the hull sufficient flotation material that would allow the recovery of the boat.

Propulsion: Only one propulsion devise is allowed and the total effort must be applied to the water

Machinery: The motor brand or make is open, and outboard motor is a mechanical assembly which can be removed from the boat as a single unit, complete with its transmission, and which does not transmit the power through the hull at any point. The motor thus taken off and placed ashore, must be capable of being started, fed by its fuel tank. Any mechanism intended to modify the angle of attachment and/or the height of the motor is authorized.

The mounting supports fixed to the boat, the control levers, the tachometer with its connections, the battery with its conductors and the fuel tank and lines do not form part of the power unit.

Classes Outboard	Capacity	Fuel
O 2000	1501 to 2050cc	Sport Fuel Rule 508.02
O 3000	2051 to 3000cc	Racing Fuel Rule 508.03

Low emission engines complying with EPA regulations will be allowed a 30% greater cylinder capacity of *their* class. In addition, the effect of any air compressor used in support of and as part of the fuel injection system, shall be ignored in determining class displacement.

#### 4. Inflatable Boats Classes:

Classes of Outboard Inflatable Racing Boats: are determined solely on cubic capacity of the engine used and are distinguished as follows:

##### **Hull:**

- a) Boats can be inflated only with atmospheric air and the number of independent compartments must be such that the boat can float even if one half of the compartments is deflated.
- b) The boat must be deflectable, collapsible or foldable so that no dismantled part has a length greater than two thirds of the full length of the inflated boat, excepting the floor boards.
- c) The keel, inflatable or rigid, must extend along the whole boat and be properly fixed to the transom.
- d) The transom can be modified only for reinforcement purposes.
- e) The boats must conform with a model of the official catalogue of the manufacturer published during the last quarter of the previous year.
- f) Boats with a rigid underwater body made of fibreglass or any other type of rigid material are not allowed.
- g) Only original features provided for by the manufacturer are allowed under the water line.
- h) No other material can be inserted or attached between the floor and the bottom of the hull except the keel.
- i) Class 1,850 V: the only shape allowed is a V shape hull. Boats that tend to have the shape of a multihull are to be excluded, even if they are included in the official catalogue of the manufacturer. The transom must be made of rigid material to adequately support the motor.
- j) Length of the Hull: The minimum dimension are 3.50 m (11 ft 5 in).
- k) Racing Capsules: are not permitted.

**Engine Mounts:** The engine must be attached to the transom of the hull, at least in four points.

**Engine Cover:** All engines must run with their cover on.

**Propulsion:** Only one propulsion device is allowed and the total effort must be applied to the water.

**Transmission:** An efficient gear changing system giving forward, neutral and astern movement is compulsory. The gear control handle must be within easy hand reach of the driver.

**Starter:** An electric or manual starter must assure quick and easy start without external aids.

**Machinery:** The outboard motor is a mechanical assembly which can be removed from the boat as a single unit, complete with its transmission, and which does not transmit the power through the hull at any point. The motor thus taken off and placed ashore, must be capable of being started, fed by its fuel tank. Any mechanism intended to modify the angle of attachment and/or the height of the motor is authorized.

To be homologated as a sports motor, an outboard motor must be sold and advertised by an industrial firm as being manufactured in standard production series (with all identical dimensions, weights and material).

The mounting supports fixed to the boat, the control levers, the tachometer with its connections, the battery with its conductors and the fuel tank and lines do not form part of the power unit.

The motor must be able to function at reduced speed. When the motor is in the water, the cooling must be done by the water circulation pump.

Classes	Outboard	Capacity	Fuel
P 550	550	up to 550 cc	Sports Fuel Rule 508.02
P 550 V	550 V	up to 550 cc	Sports Fuel
P 850	850	up to 850 cc	Sports Fuel
P 850 V	850 V	up to 850 cc	Sports Fuel



The engines that comply with EPA regulations will be allowed to compete with a 30 % greater capacity in their corresponding class.

#### 5. Rigid Inflatable Boats Classes

Classes of Outboard Rigid Inflatable Racing Boats: are determined solely on cubic capacity of the engine used, type of hull and are distinguished as follows:

Classes: as per U.I.M. rule 566.

Hull: as per U.I.M. rule 567 Except 567.01 and 567.03 Hull is monohull

Machinery: as per U.I.M. rule 568.

# **901 - RULES AND CODE OF PRACTISE FOR JETSPRINT RACING**

## **CONTENTS**

1. General Rules.....	439
Course Design.....	441
Event Administration.....	441
Promoters Responsibilities.....	442
2. Boat and Safety Equipment.....	442
Safety Harness.....	442
Engine Mounts.....	443
Fuel Tanks and Fitting.....	444
Batteries.....	444
Fire Extinguishers.....	444
Steering.....	445
Engine Control.....	445
Personal Safety Equipment.....	445
3. Roll Cage Specifications.....	447
Roll Cage Construction Materials.....	448
Welding and Forming.....	448
Configuration.....	448
Method of Securing.....	449
Anchor Points.....	450
Bolting.....	450
Crew Protection.....	450
Drawing 1.....	451
Drawing 2.....	452
Drawing 3.....	454
4. International Jet Sprint Classes.....	455
Superboats.....	455
International Group A.....	456
5. Testing Procedures.....	461
Testing Apparatus.....	462
Method of Testing Group A Class.....	462

Workshop Capacity Testing .....	463
6. Sportsmanship and Competitor Code of Conduct .....	463
Penalties .....	466
Overview .....	466
Appeals .....	467
7. Event Rules .....	468
Definitions .....	468
Signals .....	469
Race Procedure .....	470

## 1. GENERAL RULES

1. **BOATS** Any boat size, type and configuration, with a reciprocating engine, will be permitted, providing the boat is solely propelled by a water jet unit/s, carries two crew persons and complies with all safety requirements as specified under Boat and Safety Equipment rules including an approved Roll Cage.
2. **HULL** Hulls must be of metal construction up to the deck line; the deck line may not go down to the chine. All decks must be fitted in such a way as to add strength to the hull, and be permanently fixed.
3. **EXHAUST** The use of an efficient manufacturer brand muffler is compulsory. All boats will be required to meet supplementary track regulations for noise. These limits shall be notified by the race organisers/promoter 30 days prior to the departure of any international crew. (Opportunity must be given for crew to meet noise restrictions prior to any race)
4. **CONFIGURATION** Driver and crew will sit side by side with a difference in seat placement fore or aft, of not more than 300mm to each other. Crew shall have a clear and unhindered escape route through the front of any roll cage.
5. All boats must carry two crewmembers (driver and navigator).
6. The timekeeper's word is final and no protests will be considered. The timekeeper's van/area is out of bounds to all competitors and

their crew at all times except by direct invitation of the Sprint Controller. This also applies to the race control area.

**PENALTY:** Unauthorised entry to race control area and timekeeper's van/area or contact with the timekeeper - may result in disqualification for the remainder of the day's racing.

7. Any boat may have a maximum of two crews. Each driver is to have his or her own navigator. Doubling up is prohibited (ie. no driver to navigate, navigator cannot drive, navigator can only navigate for one driver, driver can only compete in one class).
8. No driver or navigator may compete in more than one boat or class on race day. However, if a boat is rendered unable to continue racing, the sprint controller may permit the crew to continue racing in another boat, providing they can record a qualifying time in that replacement boat before the elimination rounds commence. Times previously recorded in the disabled boat will be disregarded. Only one boat change per crew per meeting is allowed.

**PENALTY:** Boat substitution or change without approval - disqualification for the day or remaining rounds.

9. All items named in Boat and Safety Equipment shall be available for inspection at the time and place nominated for scrutineering.

**PENALTY:** Race-day non-starter.

10. Scrutineering shall be at a time and place as nominated by the event organiser on the entry form and must be attended by all boats and crews unless prior arrangements are made with the organiser. The scrutineering area is declared an alcohol-free zone.

**PENALTY:** Not attending scrutineering without prior approval - race-day non-starter.

**PENALTY:** Consuming alcohol in any alcohol-free zone - race-day non-starter.

11. Entry forms submitted without payment or incomplete will be deemed invalid and disregarded. Late entries will only be accepted at the sole discretion of the promoter and may be subjected to a late entry fee

and/or may be placed on a cancellation list. If a competitor wishes to withdraw an entry prior to the event, refund of the entry fee is at the discretion of the promoter. Entrants who are a “no-show” on race day are not entitled to a credit or a refund of their entry fee.

12. All drivers in order to compete, must be full financial members of their respective country’s association or jet sprint authority, financial crew members from affiliated clubs and associations and licensed international crew members are deemed to meet this requirement.
13. Points accrued in any international series will be deemed to have been earned by a driver, not a particular boat or crew combination.
14. No driver shall compete with an injury or disability, which, in the opinion of the sprint controller could adversely affect his/her ability to safely and effectively control the boat. This includes the ability of either crewmember to safely and quickly exit the boat following an accident. Medical clearance in writing may be required before a driver or navigator is allowed to race.

## **COURSE DESIGN**

International Events will only take place on suitable tracks homologated by the IJF, or its duly authorised agents. For more information contact the U.I.M. Jetsprint sub-commission  
Phil Dixon. Email : phil@ausprologistics.com.au

## **EVENT ADMINISTRATION**

1. A Sprint Controller will be appointed to control each event.
2. The Sprint Controller is the final arbiter for any disputes other than official protests on the day.
3. An approved host country authority member who has had at least two years experience in Jet Sprinting shall carry out Scrutineering. Any queries, which cannot be satisfactorily resolved by the scrutineers, shall be referred to the sprint controller for a decision the Sprint Controller is the final arbiter.

4. The IJF reserves the right to alter any of the above rules so as to accommodate any unusual or unforeseen circumstance or errors that may arise from time to time or country to country

## **PROMOTORS RESPONSIBILITIES**

1. Promoters of all events must provide adequate first aid equipment, for any likely emergency, and ensure the attendance of qualified first aid personnel and an ambulance available at trackside.
2. Promoters of all events must provide adequate fire extinguishing equipment for any likely emergency. (Race gas and Methanol). It is preferable to engage the services of a trained fire crew.
3. Promoters of all events must engage the services of at least 20 able bodied people to act as boat pushers. Although the primary requirement is to assist with refloating of boats, which have become grounded, an essential aspect is an ability to quickly react and assist with any craft in difficulties that may endanger the crew. (i.e. a roll-over) The Pushers must be given a safety briefing prior to commencement of the event, so that they are conversant with the requirements regarding the safety of a crew in the event of a roll-over under water and that they are aware all other safety requirements concerning their own safety in the handling of boats.

## **2. BOAT AND SAFETY EQUIPMENT**

### **SAFETY HARNESS**

1. Must be fitted for both crew and be securely attached to the roll cage or the seat base bearers. They must be a motor sport type approved and a minimum of 50mm web for lapbelts, 75mm web for other belts, a 5 attachment point harness is the minimum, a 6 point is recommended both shall have a lever action quick release buckle and be within their use by date as set by the manufacturer. (See roll cage specs) Push lock or twist action buckles are not permitted.
2. The mounting point for the shoulder straps behind each crew member must be between a line horizontal to the shoulders, and a line drawn downward from the shoulders at an angle of 25 degrees

to the horizontal. If the shoulder straps join prior to a single common mounting point then that junction shall be at least 150mm behind the crew members neck.

3. All harnesses shall be replaced whenever the webbing is cut, frayed or weakened due to the actions of chemicals, abrasion or sunlight, etc. Safety belt harness hardware must be replaced if it is bent, deformed or rusted.
4. The lap and crotch straps may not pass over the sides of the seats but through the seats in order to wrap and hold the pelvic region over the greatest possible surface. Care shall be taken that the webbing of the harness is protected against chaffing in any area.
5. Shoulder straps must wrap around the horizontal cross bar of the roll cage as the only means of attachment.
6. All Drivers and Navigators must be scrutineered with their nominated boat so their safety equipment can be checked for correct size.
7. Motor sport type approved arm restraints must be worn on the outside wrist of each crew member and shall be of a length which will prevent the arm from protruding from the boat in the event of a roll over. They must be attached to the safety harness in such a way as to release freely when the buckle is released.
8. Head restraints for both driver and navigator are compulsory, these may be either motor sports approved mounted from the shoulders to the helmet or the fixed type from to the seat back head rest protruding out each side of the helmet in a line drawn forward past half the forward length of the helmet when the head is rested to the back of the seat in the sitting position. Head restraints must have the ability to absorb the side to side impact of the head under racing conditions without being left permanently bent out of shape after normal racing.

## **ENGINE MOUNTS**

1. Engines are to be solid mounted to the main engine bearers. Where an engine mount is built to create a frame there shall be a minimum of four, 3/8 in. bolts or metric equivalent to secure that frame to the

main bearers of the boat. Where engine mounts create four separate attachment points there shall be a minimum of eight, 3/8 in. or metric equivalent.

2. Flexible mounts will only be permitted if they have security through bolting and it can be demonstrated to the scrutineers' satisfaction that the through bolt is designed to restrain the engine should the flexible portion fail.

## **FUEL TANKS AND FITTING**

1. Fuel tanks must be securely mounted and be fitted with a non spill sealing cap. The tank must not be mounted in such a way as to be a stressed or a load bearing part of the boat structure.
2. Adequate breathers are to be fitted to the fuel tank, the breather tube must include a non return valve and be vented to the outside of the boat.
3. A fuel filler must be fitted in such a manner that no fuel can spill into the hull during refuelling.
4. All fuel and vent lines must be resistant to the type of fuel used. All fuel lines must be attached with proper fittings no hose clips or clamping of fuel lines is permitted. (With the exception of the fuel filler to the scrutineers satisfaction)
5. A fuel shut off tap or control is optional.

## **BATTERIES**

1. The battery should be of a non-spill, (ie. manifold-vented or gelled type) and firmly secured to the hull or bearers.
2. An operating battery isolating kill switch must be installed and located between the seats within easy reach of both crew whilst harnessed in their seats. Metal constructed boats should have the isolating switch to the earth terminal.

## **FIRE EXTINGUISHERS**

1. Approved fire extinguishers must be carried on the front of boat trailers. They must be easily accessible.



2. Approved Types: The extinguisher fitted to any boat must be of a type designed to extinguish the fuel type used in that boat.

All types must carry standard approval label. Aerosol types not permitted.

## **STEERING**

1. All shackles and turnbuckles in the steering system must be lock-wired. (Nylon TY wraps are acceptable)
2. Chain guards/guides must be fitted to each side of the steering chain sprocket. All open pulleys must be fitted with keepers. Where steering is a lever system any shackle attaching steering cables shall be lock wired. Especially designed taper lock cable joiners may be accepted at the scrutineers' discretion. All steering cables must be from a braded type wire rope, with a minimum 750 kg breaking strain.
3. Jet unit steering shafts where fitted shall have Nylok type nuts, the thread of any bolt must protrude through the nylon locking device or have been locked by fitting two standard nuts.
4. An operational reverse is mandatory for all boats.

## **ENGINE CONTROL**

1. Two throttle return springs, either of which is capable of closing the throttles, must be fitted in addition to any internal carburettor throttle shaft springs. Where fuel injection is fitted there will be at least one spring on the accelerator pedal in addition to the factory fitted springs on the throttle shafts. Where this is not possible the spring will be fitted to the main operational lever of the fuel injection where the throttle cable is attached. At all times for any boat the throttle must be able to return to the idle position unaided.
2. Any other items that in the opinion of the scrutineer are unsafe must be rectified to the scrutineers' satisfaction.

## **PERSONAL SAFETY EQUIPMENT**

1. Safety equipment must be properly and securely fitted to the crew, prior to the boat lining up at the start line and all must be in place

when the boat crosses the finish line. No other items of clothing shall be worn over the fire retardant suit.

2. A bow-towing eye with at least a ten mm hole must be fitted with a d-shackle to suit, to aid the rescue crew or towboat to attach a safety line.
3. The driver shall be responsible for checking that his or her crew is wearing the required safety equipment and that it is correctly adjusted, before proceeding onto the start line. The starter will visually check safety equipment prior to allowing any boat to cross the start line, but will not be responsible for any item not being in place during competition.

**PENALTY:** Incorrect fitting or missing safety equipment during run - DNF

4. All crew in boats must wear Motor sport approved flame retardant balaclavas and hand protection. Balaclavas with openings from eyebrows to above the chin are acceptable. Balaclavas must not be of the peephole type, the mouth and nose must be easily cleared. The table below outlines the minimum requirement for double layer fire suits or single layer suits worn with fire retardant underwear.

<b>Single Layer Suit</b>		<b>Fire retardant Underwear</b>		<b>Balaclava, Gloves and Boots</b>
SFI 3.2A/1 ASC F RA611	<b>plus</b>	FIA8956-1986 FIA8956-2000 SFI 3.3	<b>plus</b>	FIA8956-1986 FIA8956-2000 FIA- ISO6940 SFI 3.3
		<b>or</b>		
		<b>Two plus layer suit</b>	<b>plus</b>	<b>Balaclava, Gloves and Boots</b>
		FIA8956-1986 FIA8956-2000 SFI 3.2A/5	<b>plus</b>	FIA8956-1986 FIA8956-2000 FIA- ISO6940 SFI 3.3

5. All competitors whether they are competing or practicing must wear a correct fitting approved helmet; motor sports type neck brace, arm

restraint, enclosed footwear and fire retardant suit. Cotton workman overalls will not be accepted.

6. Any brand of crash helmet is allowed provided they meet the standard specifications applied by the Jetsprint authority in the Country of origin of the boat and crew concerned. Approved Internationally manufactured helmets may be eligible for competition use, consult an IJF representative for approval. Open face types only. All helmets must be in excellent condition with no frayed chinstraps or rusted anchor points and must correctly fit the person who wears them. Full-face or types with removable face pieces are not acceptable.
7. A working bilge pump is optional.

### **3. ROLL CAGE SPECIFICATIONS**

1. A roll cage, which meets these minimum specifications, must be fitted to all boats.
2. Boats not complying with these standards will not be permitted to race.
3. The intention of these specifications is to provide the best possible protection to drivers and navigators, taking into consideration the accidents, which have occurred within the sport, and best practices in other motor sports. No guarantee is implied or stated, nor is any responsibility taken, regarding the degree of protection or safety afforded by any roll cage constructed to these specifications. Owners are encouraged to seek the advice of a structural engineer qualified in roll cage design.
4. All jet sprint boats are to have roll cages constructed so that all parts of the crew's bodies above the deck line are contained within the roll cage structure. At the same time, the roll cage should provide minimum restriction to the driver's vision to the sides or front and must allow quick and easy access and exit, especially in the event of an inverted accident. While different designs of roll cages will be permitted, each design must satisfy the requirements stated above and be constructed to the following minimum specifications.

## **ROLL CAGE CONSTRUCTION MATERIALS**

1. Only round chrome moly tube is acceptable minimum diameter 38.1mm Wall thickness 2.1mm.
2. Capping plates - minimum 3mm steel or chrome moly. Roll bar capping must not be drilled or have welds ground back for appearances.
3. Attaching plates - minimum 5mm steel or chrome moly.

## **WELDING & FORMING**

1. All joints must be fully welded by a competent welder with all welds being of good external appearance and remain un-ground using the TIG or MIG process with the 4130 filler wire, for chrome Moly.
2. Joints should be preheated and welded in 90-degree increments to avoid brittleness. (Chrome Moly)
3. Tube must be contoured and shaped for a close fit prior to welding.
4. Tubes cannot be flattened in order to make a joint.

## **CONFIGURATION**

1. All bracing and the rear A frame must be straight between attachment points. (Drawing one)
2. The main A frame roll cage structure and brace bars must be of one-piece continuous tubing. No welds permitted other than at attachment points and capping plates.
3. The top corners of the overhead framework must be formed with one 90 degree formed on a bender suitable for bending the chrome moly size used.
4. The two A frames must be spaced apart a minimum of 100 mm between centres.
5. Capping plate (3 mm) must be welded to each corner of the A frame covering the entire bend. (May be mild steel)

6. A minimum of one (3 mm) plate or tube must be welded in between the capped A frame corners between the top bars.
7. The mounting points on the cage for the shoulder straps behind each crew member must be between a line horizontal to the shoulders and a line drawn downward from the shoulders at an angle of 25 degrees to the horizontal.
8. The two A frames must have a brace on the side so as to form an A section on the side of the cage and should where possible also be attached to the side panel (gunwale) as well as the chine.
9. Helmet Clearance; 5 or 6 point harness, a minimum clearance of 100 mm from the top of the helmet to the underside of the cage top bar must be maintained for all crew.
10. An X styled brace going from the upper outer A frame to either:

The back cross bar and then down to the engine bearers or outer chine area. (The bottom part of the X brace can be removable in this configuration provided suitable hardware is used)

Goes directly to the engine bearers or chine and joined where they intersect. (If the lower part of the X brace goes to the chine it must have suitable load distributing plates on attachment points)

11. Seats must mount to the one piece cross bars shown in drawing three and be attached at all manufacturer located mounting points or a minimum 4 points at the base and 1 at the back above the shoulder line of any crew.
12. All attachment points to the seats must be a minimum of 3 mm mild steel and able to support the entire weight of the crew throughout any crash without distortion to the mount between the seats and roll cage crossbars or cross members.

## **METHOD OF SECURING**

1. Attachment plates or load-spreading flanges must be welded to the tube ends to secure the cage to the boat and must be at least 5 mm minimum thickness.

2. For rectangle attaching plates:

Minimum width of attaching plate = tube diameter.

Minimum length of attaching plate = tube diameter x 2.

3. For circular attaching plates:

Minimum diameter of round flanges should be tube diameter x 2.

The roll cage may be bolted or welded to the boat as defined below.

### **ANCHOR POINTS**

1. The primary elements of the roll cage must be secured to the main engine bearers and the chine.
2. In the absence of chine bearers in an alloy boat, the cage should be attached in the chine area of the bottom skin with load-spreading flanges as above.
3. In addition to the above, the main roll bar structure may be attached to the fore or side deck, provided that a brace bar of the same type and size material as the roll bar continues the load path through to the bottom of the boat. Provided the primary elements of the roll cage structure attach to the boat bottom as stated above, then braces may be attached to the roll cage in order to strengthen the boat sides or deck structure.

### **BOLTING**

1. Through bolting with back-up washers.
2. Minimum of two bolts per attachment point.
3. Minimum bolt diameter 3/8in for two bolts, four bolts - 5/16, six bolts ? etc or metric equivalents

### **CREW PROTECTION**

1. The driver and navigator must be able to exit an inverted boat through the front area of the roll cage with no frame members in such a position as to impede their exit or rescue.

2. The frame of the cage must protect the crew from any frontal or inverted impact to their head and torso and must be able to restrain the engine from moving forward far enough to cause injury by having suitable cross-members in place.
3. A minimum clearance from the top of the crews' helmet to the underside of the roll bar will be 100 mm (4 inches) for a five or six-point harness.
4. Roll cage padding with a minimum 20mm thickness must extend a minimum of 180 degrees around the roll cage tubing, and be of high density foam padding. Padding is to be placed where in the event of an accident the expected trajectory of the occupants heads are likely to make contact. It is not advisable to place this roll padding above the helmet area if it reduces the helmet clearance specifications. Recommended but not compulsory.

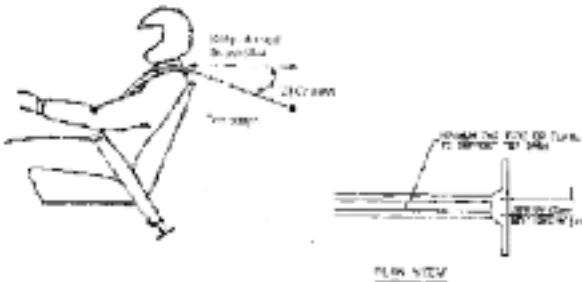

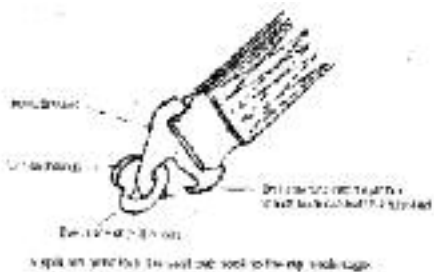
BACK VIEWBACK VIEWBACK VIEWBACK VIEW



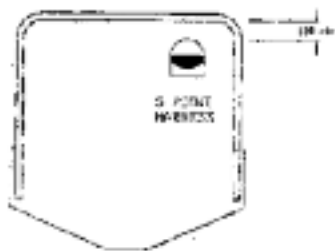

HELMET CLEARVIEW



SIDE VIEW



## **4. INTERNATIONAL JET SPRINT CLASSES**

### **SUPERBOATS**

1. All naturally aspirated engines must be a minimum of 6.5 litres displacement, and if any naturally aspirated engine is under seven litres displacement, it must be equipped with alloy heads, use methanol fuel and have multi carburettors or fuel injected induction system.
2. Forced induction engines must be a minimum of 3.8 litres displacement.
3. Under special circumstances it may be possible by request, to have boats that do not comply to the above requirements, to be awarded Super boat status.
4. If Superboat status is granted, the boat will only be eligible to compete in the Superboat class for that season then would need to re-apply.
5. The use of fuels other than petrol is permitted. The only Methanol (alcohol) fuel is Mobil No 5 and equivalent Oil Company brand Fuels. The use of any nitrous oxide or nitro Methane type fuels is prohibited.
6. The minimum age for Super class competitors shall be 18 years of age for drivers and 16 years of age for navigators. Proof of age will be required on demand.
7. Injected or supercharged engines that require external fuel priming for starting purposes shall have one crew member identified as the primary starter for that boat. This person shall be equipped with and wear the following at all times whilst attending to starting duties on the boat ramp (including warm up facilities). Fireproof balaclava, minimum fireproof arm sleeves, eye protection. A single layer fire suit is deemed adequate arm protection and recommended. One primary starter may act for several boats.

Penalty for missing safety equipment for primary starter whilst externally priming the fuel system is a DNS in the offending round. Applies to qualifying and elimination rounds.

## **INTERNATIONAL GROUP A**

1. The minimum age for Group A competitors shall be 16 years of age for drivers and 16 years of age for navigators. Proof of age will be required on demand.

### **JET UNIT**

Single unit only, direct drive only (no gearboxes) otherwise no restriction.

### **ENGINE CONFIGURATION**

2 valves per cylinder, push rod operated, maximum of 8 cylinders, single engine and internal combustion only. The nominal section of each cylinder must be circular.

### **OILING SYSTEM**

Wet sump only. Single stage external oil pumps and OEM location oil pumps only. Oil accumulators are allowed. ***Vaccupans are allowed.***

### **CONRODS / CRANK**

No Titanium or aluminium.

### **ENGINE BLOCK**

Cast iron only.

### **ENGINE CAPACITY**

412 cubic inches (6,752cc) maximum swept volume.

### **CAMSHAFT**

One only in OEM production location. No restriction to valve lift or rocker ratio. Shaft mounted rockers are permitted. Offset rockers are permitted to relieve the problem of pushrod to cylinder head interference created by some aftermarket heads. Maximum offset is 0.250". Offset rockers are permitted for OEM cylinder heads where pushrod tubes have been inserted to gain port width comparable with aftermarket castings. Max offset is 0.250". Devices that vary the valve timing whilst the engine is operating are prohibited.

## **CONNECTING RODS**

Must be of ferrous alloy material.

## **CYLINDER HEADS**

Cast iron only. OEM location in relation to bore only. Valve angle 23 degrees to block face, original cylinder head manufacturers location only. No angle milling allowed. Maximum 0.50 degree (either way) valve angle testing tolerance measured from block deck surface. Block deck surface to be 90 degrees from bore centre line.

## **INTAKE PORTS**

Cylinder head Intake port dimensions at manifold flange are not to exceed an unmodified Felpro 1207 gasket port opening (Felpro published dimensions 1.38"x2.28").

## **INTAKE PORT & BOLT LOCATION**

OEM production location. No high port or raised runner heads. Felpro 1207 max size gasket template must be in original cylinder head manufacturers position and orientation in relation to bolt holes. No part of the intake manifold gaskets may protrude into the ports. Maximum distance of 2.500" allowed from roof of port to block surface side of head. Measurement is made along the plane of the intake flange face and not perpendicular to deck surface. (Chevrolet specific rule only).

## **EXHAUST PORTS OEM**

Production location only. Exhaust flange adaptors are permitted as long as no material from the manifold, the adaptor or any gaskets or seals protrude into the port past its original outside face.

## **VALVES**

Maximum sizes - 2.125 inch intake, 1.625 inch exhaust.

Valves may only be opened by mechanical action, and can only be closed by means of coil springs. There are many after-market manufacturers that produce complying cylinder heads - GM Bowtie, Dart etc. There are also some cast iron heads produced as "23 degree" that

don't meet the specified rules. Some heads angle milled from the factory are an example of this.

## **INDUCTION**

Naturally aspirated only via a single 4-barrel carburettor with a maximum of 4 venturis. Carburettor throttle body bores below the throttle shaft centerline shall not exceed 1-11/16 inch diameter. Butterflies or throttle blades shall not exceed 1-11/16 inch diameter.

Compliance will be checked by measurement or a "Go-No Go" type gauge applied to the throttle body bore below the throttle shaft centreline.

Any mass produced cast intake manifold is permitted. Inlet manifold must use OEM bolt pattern and position to mount to cylinder heads without the use of adaptors or spacers.

No sheet metal or tunnel ram style inlet manifolds are permitted. The intake manifold must remain largely visually standard and unmodified from the outside. Sectioning the plenum for porting access and re-welding is a permitted exception. No additives may be discharged into the inlet tract. Any device which alters the configuration of the manifold/induction systems (e.g. movable inlet rams) or exhaust while the engine is operating is prohibited.

Engines not exceeding 365 cubic inches maximum swept capacity may be fitted with aluminum cylinder heads conforming with these rules only.

## **FORD ENGINES**

Same common rules as Chevrolet engine.

Cylinder heads - Part Number M-6049-N351. No Thermactor or EGR Ports.

OEM production position.

Valve angle 10 degrees to engine block face.

Intake port size, template FELPRO Gasket, Part Number 1262.

All port and bolt locations OEM production positions only.

## **TRADITIONAL PONTIAC ENGINES**

Same common rules as Chevrolet engine except.

### **CYLINDER HEADS**

Cast iron only. Valve angle 14 degrees to block face (OEM specification), Original cylinder head manufacturers location only. D-port or round port exhaust.

### **INTAKE PORTS**

Template SCE gasket 128105 max size (1.18"x2.30") Offset rockers are permitted for OEM cylinder heads where pushrod tubes have been inserted to gain port width comparable with aftermarket castings. Max offset is 0.250" .

### **VALVES**

Maximum sizes - 2.110" intake, 1.770" exhaust (OEM 400 cid).

### **EXHAUST PORTS**

Exhaust crossover, EGR or heat riser passages may be filled with aluminium. Epoxy may be used to seal this at the intake manifold flange.

### **INTAKE MANIFOLD**

Separating the water crossover from the intake is an acceptable modification.

NOTE: Engine options may be expanded in the future provided they offer a similar power-to weight ratio. Applications for engine consideration must be made and supported by full technical specifications. Any engine under consideration will be subject to supervised trials before approval for competition is granted.

### **COMBINED RULES AND LIMITS ON MODIFICATION (ALL MAKES)**

No angle milling of heads allowed. Maximum 0.50 degree (either way) valve angle testing tolerance applies to factory valve angle.

Porting is permitted but no material may be added to any part of the cylinder head casting (unless specified in that engine family specific

rules) Includes but not limited to aluminium ramps, epoxy, brazing, furnace cement etc.

Welding is permitted for crack repair purposes only but is limited in the port, intake and exhaust runner area to a maximum of 2 repairs per cylinder head.

Welding in the chamber area for crack repair only is limited to 2 chambers per head but must not alter the shape or size of the combustion chamber.

Replacement of valve guides are not considered to be a repair.(see below).

All machine work for valve guides, spring and valve seats must remain parallel & in original cylinder head manufacturers position. No offsetting of valve guides is permitted.

Any machined surface must remain parallel to original surface.

Repair sleeves or tubes of any material may be fitted to either the head bolt or pushrod holes.

Head bolt = 1 repair max per cylinder head.

Pushrod hole/slot = 2 repairs max per cylinder head for aftermarket cylinder heads.

Pushrod hole/slot = 4 sleeves or tubes permitted per head for OEM heads to gain port width comparable with aftermarket castings. Max rocker offset is 0.250".

***No restriction on intake valve seat inserts.***

No restriction on exhaust valve seat inserts.

**CONTROL FUEL**

Will be provided at all international meetings by the promoter and paid for by competitors of the class involved.

**FUEL**

Will be 100 octane Race gas. The control fuel will be dispensed either from a central point to which each boat must come, or by smaller



containers refilled from the main source. The scrutineer will be in charge of and oversee all refuelling operations. Fuel tanks are not required to be drained prior to the addition of control fuel provided that a tank has maximum capacity of not more than 30 litres.

## **5. TESTING PROCEDURES**

1. At any meeting, any boat's engine capacity and compliance with restrictions may be tested, at random, without notice. The decision to conduct testing shall be made by the committee prior to the commencement of that meeting. Other boats may be tested, time permitting, as the chief scrutineer or his appointed deputy sees fit, but only after they have been eliminated for that day.
2. The crew of any boat found to have an illegal engine capacity or components outside of the specifications or restrictions will be disqualified and will lose all points and placing's gained since that boat's last compliance test.
3. The crew holding lower placing's will move up in the finishing order one or more positions as required. Where boats are disqualified and the finish order reshuffled, the top three must still be tested prior to presentation.
4. Testing will be conducted by the chief scrutineer or appointed deputy and in the continual presence of the boat owner or designated representative.
5. Refusal to allow an engine to be tested will be taken as evidence of over-capacity or outside of specification and the stated penalty applied immediately.
6. The results of the capacity and compliance testing as detailed will be final and no protest will be entered into provided the equipment falls within its manufacturer set tolerances.

Note: All testing methods must be approved.

## **TESTING APPARATUS**

1. A measuring flask of 1,000cc's certified capacity (known brand name) and have sufficient height so as to have distinct and well-separated graduations.
2. A length of flexible hose 300mm to 500mm long with one end attached to the bottom of the measuring flask, the other end able to accept either a large or small spark plug hole fitting, drilled to allow fluid to pass.
3. One litre of testing oil, to be a recognised upper-cylinder lubricant.

## **METHOD OF TESTING GROUP A CLASS**

1. Engine must have: - All spark plugs removed, one rocker cover removed, both rockers on one cylinder backed off, so that the valves remain closed at all times.
2. Bring the piston to approximately TDC on the cylinder being tested.
3. Screw the measuring flask connecting hose into the spark plug hole.
4. Fill the measuring flask with testing oil and raise the flask above the cylinder, keeping the connecting hose as vertical as possible.
5. Turn the engine over slowly by hand until no more air bubbles are expelled.
6. Turn the engine over slowly by hand three times, recording the maximum and minimum level readings each times. (At all times, the oil level must remain within the graduation range of the flask). The oil level may be topped up in between reading sets if necessary and the process should be repeated until two readings are within 8cc of each other.
7. Taking the difference between the two readings and multiplying by the number of cylinders will yield the total engine displacement. For Group A boats, this may not be more than 6752 cc or 412 Cubic inches.
8. Maximum allowable capacity for one cylinder is  $844\text{cc} + 1\% = 852\text{cc}$  for Group A boats. (8-cylinder engine)

9. The engine will be classed over-capacity if: Measuring flask reading is more than 852cc (for Group A) per cylinder, the engine cannot be turned over one full revolution.
10. Oil leakage from the cylinder is such that no two readings are within 8cc (in this case, another cylinder must be tested. The number of cylinders to be tested is at the scrutineers' discretion).
11. Note: Competitors suffering a total engine failure, such that the engine cannot be capacity tested as above will be workshop capacity tested.
12. The method of testing Superboat engine capacities, will generally be those as indicated above for Group A class, however capacities should be substituted so as to comply with the class capacity rules.

#### **WORKSHOP CAPACITY TESTING**

1. Only one head of a "V" configuration engine need be removed to enable access to the cylinder bore for the purpose of accurately measuring the bore and stroke of that engine. The resultant calculated swept volume shall not exceed 412 Ci. or 6752 c.c.'s for Group A. At this time the engine should be measured and inspected for full compliance with the specifications outlined herein.
2. There shall be no tolerance permitted when the capacity is measured in this manner.

#### **6. SPORTSMANSHIP AND COMPETITOR CODE OF CONDUCT**

1. There is a total commitment to promote and foster good sportsmanship within the jet sprinting movement. This is to assist in the creation of a strong, positive public image of a group of competitors with a professional attitude, providing exciting, spectacular entertainment.
2. All competitors, their crew and race officials are expected to understand and display, in public, all those qualities which define good sportsmanship.

3. Obvious public displays of bad sportsmanship by any member will be considered a breach of the code of conduct and subject to disciplinary action.
4. The code of conduct requires not only a public display of good sportsmanship, but compliance with the rules of racing and the contractual obligations of the individual competitors and their teams via the signed entry forms carrying conditions relating to behaviour and general codes of practise as outlined in these rules.
5. During a pit walk by members of the public at least one member of the boat crew shall remain with the boat to foster good relations and public image by interacting with spectators as they view the boats in the pit area.
6. All personnel involved with an event, competitors, their crews and officials are required to function within the code of conduct.
7. The pits are a controlled-access area and an alcohol-free and smoking-free zone. Entry is confined to competitors who are entered on the day, pit crew, officials and those holding pit passes. Non-competing, financial members may not use their licence as a pit-pass, and not as a free event entry pass. Children must be under the control of a responsible adult at all times.

PENALTY: Abuse of licence. Cancellation of licence for six months.

PENALTY: Smoking or drinking alcohol in the pits - exclusion from the pits for the remainder of the meeting. Competitors or officials will be suspended for one meeting. Repeat offence - 12 months suspension.

8. There is a total ban on the consumption of alcohol and any other intoxicating substances by all boat crews and all event officials, including safety crews, for 8 hours prior to the commencement of briefing and for the duration of the meeting, or until they have completed their racing activities for the day. No crewmember, or support crewmember may consume alcohol whilst wearing racing apparel. Crews are required to have a zero blood alcohol content prior to racing and to comply with insurance conditions. Breathalyser testing of crews may occur, prior to commencement of racing. This

ban applies to prescribed drugs and other performance-affecting substances. No alcohol may be consumed in the pit area by any person during racing.

9. A declared alcohol free zone refers only to the consumption of alcohol and/or prescribed drugs by any person in that area, and does not presume to enforce civil law relating to the possession or presence of it in a vehicle which may be parked in that area. However, any member who willingly breaks a civil law concerning prescribed substances in a manner which brings the sport into disrepute, may be deemed to be in a breach of the code of practice and can be penalised as provided for in the general rules of IJF.

PENALTY: Consumption of alcohol during meeting: minimum one meeting ban.

PENALTY: Competitors registering any blood/alcohol content prior to racing: - start denied until breathalyser registers zero.

10. Smoking is prohibited in the pit area. Any person smoking in the pit area may cause the disqualification of their associated boat. A crew smoking area may be established adjacent to the pit area at each track.

PENALTY: Disqualification for remainder of the days racing.

11. No competitor may abuse a race official. Any competitor, who has a dispute with any official on race day, must present the details of the problem to a class representative who may consult with the Sprint Controller for resolution. Likewise, any competitor who has any complaint concerning the running of the race day must firstly present the details in person to a crew committee member. If no committee members are present, then the complaint may be presented to a race official.
12. No official may abuse a competitor. If there is a perceived problem with the behaviour of a competitor, the matter must be brought to the attention of the sprint controller. (The disputes committee will be comprised of the sprint controller, host country representative, and IJF representative)

PENALTY: Abuse of official: disqualification for remainder of the day. Further penalty may be applied.

13. No competitor or crew shall be involved in any instance of dangerous behaviour, or conduct which deliberately causes or could cause disruption to a race meeting, nor may they take any action, verbal or otherwise which may be deemed to bring the sport into disrepute.

PENALTY: minimum: disqualification for the day - further disqualification possible at the discretion of the U.I.M.

## **PENALTIES**

1. For any offence occurring on race day or as a result of scrutineering, the maximum penalty, which can be imposed by the Sprint Controller, shall be disqualification for that day. Additional penalties can only be imposed by the disputes committee following race day and after consultation with all parties concerned with the incident.
2. A penalty for a breach of the rules may, at the discretion of the sprint controller, be in the form of a suspended penalty and shall remain current for a period of up to one year from the time of the offence. Any further breach of the rules within that time shall cause the suspended penalty to be immediately applied.
3. Suspension penalties for one or more meetings shall apply from the next listed meeting and if more than one, shall be consecutive.

## **OVERVIEW**

1. The Sprint Controller shall have certain discretionary powers to deal with disputes and may make a ruling concerning a dispute.
2. The ruling will be given after due and careful consideration of the issues involved and will be final. It will not be open to further discussion on the day.
3. Any ruling, which affects the results of the day, may not be challenged on that day, but can be subject to appeal by affected competitors as per the appeals rule.

4. The disputes committee will formally advise affected persons that they have been reported for a breach of the rules or the code of conduct.

## **APPEALS**

1. The disputes committee will be comprised of the Sprint Controller, host country representative and the Commissioner.
2. Whenever possible and practical, the Sprint Controller will consult with the disputes committee when considering disciplinary action.
3. The sprint controller, may request a competitor to attend a meeting of the disputes committee, either during the event or at some other suitable time, to provide good reason why they should not have disciplinary action taken against them for a breach of the rules or code of conduct, which in the opinion of the sprint controller, could bring the sport into disrepute.
4. Failure to attend such a meeting will result in the immediate imposition of the appropriate penalty without right of appeal.
5. Notwithstanding the listed penalties, it is policy to apply penalties progressively. A warning may be issued followed by the prescribed penalty for a repeat offence.
6. A non-time related protest must be submitted in writing by a competing crewmember and accompanied by a US \$100.00 protest fee (or equivalent). It may be lodged immediately or at latest, within 15 minutes of the occurrence and handed to a class representative and the sprint controller. The disputes committee will hear the protest as soon as possible and if upheld, the fee will be refunded.
7. Any competitor who protests the eligibility of the engine of a competitor, shall be liable for all costs associated with the testing of that engine, including parts and labour if necessary, should it be proved to be legal. If the protest is upheld, the owner shall bear all associated costs.

8. Members seeking information on rule interpretations must first consult with a class representative, but if none are available, then the sprint controller may be approached.
9. Any member subjected to disciplinary action may lodge a formal appeal within 7 days of a penalty being imposed. Refer to the U.I.M. appeal rules.

## **7. EVENT RULES**

### **DEFINITIONS**

Commissioner - The U.I.M. appointed representative.

Class representative - The selected person to represent the drivers of a particular class on race day.

Disputes committee - The sprint controller, a host country representative and the commissioner.

DNS - did not start.

DNF - did not finish.

Qualifying - The rounds in which a competitor can take their best time to secure a place in the elimination.

Elimination - Meaning the rounds where a competitor has only one opportunity to progress forward with their fastest previous time. i.e. qualified time to fastest 16, fastest 8, fastest 4, fastest 2.

Run - The completion of the prescribed track by following the course directions as handed out on an official map of the race course at a given event.

Class representative - The selected person to represent the drivers of a particular class on race day.

### **PROCEDURE FOR CALCULATING POINTS IN A CHAMPIONSHIP**

Points shall be awarded depending on the placing achieved in a race as follows :



First place : 40 points

Second place : 39 points

Third place : 38 points

Etc ..

Down to Fortieth place (40th) : 1 points

Should there be more than 40 crews competing in any one class this system would need to start with the first place being awarded 50 points decreasing to 1 point for 50<sup>th</sup>.

If the event of a tie for 1<sup>st</sup> or 2<sup>nd</sup> position at the completion of the series a run off shall be held immediately.

## **SIGNALS**

1. Flags will normally initiate starts, however light signals may be used. A boat may not start until the starter gives the appropriate signal. This is a safety requirement and the driver and navigator must be satisfied that the previous boat is back in the pit area and clear of the spinout pool, the towboat is back in the pit pool and all safety crew groups are in position. (Note that the timing is triggered by the boat at a point some distance after the start lights and therefore does not commence with the display of the green light).
2. Each group of safety crew may have a red and green flag. In this instance, unless the track is clear of boats, crew or unplanned obstacles, a red flag will be displayed and a start is not permitted. A green flag signifies that the particular section of track is clear and the safety group is in position. Where it can be demonstrated that the event is efficiently controlled by two-way radios the requirement for the flag system may be waved in consultation with the sprint controller.
3. Signals - Due to the noisy environment, signals will be utilised by the starter and the safety crew. The starter has control of the start lights or flags which will be:

**RED** You may not start or pass this point under any circumstances.

**AMBER** A start is imminent, you should be idling toward the start line and are under the control of the starter.

**GREEN** You are cleared to start. The two and ten minute time limits do not apply for a normal start. (Time does not start until the timing beam is broken)

**BLACK** You are disqualified for that run.

**PENALTY:** For jumping the lights or start signal or being out of position - 10 seconds added to the time for that run. If a dangerous situation is caused, a disqualification will occur.

## **RACE PROCEDURE**

1. Each race event will commence with a roll call and crew briefing, the time of which will be advised to all drivers entered. All competitors, both drivers and navigators, must attend the pre-race briefing, the track walk safety inspection and sign any liability waiver form before racing. Competitors must be in attendance at roll call and/or briefing. Competitors who suffer an incident outside their control, and who in the opinion of the sprint controller were making every reasonable effort to attend the event on time, may be allowed to compete. In this case the competitors will be given a full and separate briefing prior to competing. As part of the briefing all crewmembers must be invited to raise any concerns over course safety.

**PENALTY:** Late to roll call on race day - disqualification for the day.

2. Event, track or boat sponsors who compete as guest navigators must sign the waiver form prior to their run and wear all specified safety equipment.
3. While racing is in progress, each boat is to have one crewmember at the boat or close by in the pit area, in case of a change to the running order.
4. There is a speed limit of 5kph or minimum idle in the pit pool and on entrance thereto, where a spin-out pool is provided each finishing

boat must use this facility to reduce speed to idle, prior to entering the channel approaching the pits. If there is no spinout pool, an alternate procedure will be advised either at the crew briefing, or in the track supplementary regulations.

**PENALTY:** Speeding in pits and/or creating a wash hazard or other danger - disqualification for the remainder of the race day.

5. No person other than official, licensed entrants and the towboat driver shall drive or compete on the track on race day without the consent of the sprint controller.

**PENALTY:** Disqualification for a period of up to one year for the crew involved.

6. Boats will start from idle power in forward thrust and may not accelerate until given the start signal which will be when they are wholly within the start gate as indicated by the starter. Cones, on the bank adjacent to the start channel, will normally mark the start gate. A third cone will indicate the 10m-aborted start limit.
7. If upon initial acceleration a problem occurs with the engine or jet unit, the driver may request one re-start immediately by reducing power and raising an arm. The boat must return to the pit-pool via the shortest possible route to the spinout pool at reduced speed before rectifying the problem, e.g. weed in intake. Use of this rule to obtain an advantage will result in a DNF (Note that time limits may be applied to restart).
8. Only one re-start will be permitted per boat per round and the abort signal must be made within 10m of the start. (A marker will be positioned to mark this limit). This allowance is not meant to compensate for a poor start and will be at the discretion of the sprint controller.

**PENALTY:** Aborting the run more than 10m from the start - DNF (see also event rule 14).

9. If a boat becomes grounded during a run, the crew may attempt to re-float their boat, only by manipulation of the engine and jet unit. They may not receive any outside assistance and no item of safety

equipment, including safety harness, may be removed during this attempt. Timing will continue until the crew is successful or the driver turns off the engine and calls for assistance by raising an arm. If the attempt is successful, they may continue racing and can record a time. (There will be a 20 second time limit on re-floating your boat in this manner).

**PENALTY:** For removal of safety equipment or receiving outside assistance - DNF.

10. When a boat is grounded and the assistance of the safety crew is required, the following procedure must be adhered to: The driver must shut off the engine and raise one arm to signify that assistance is required.
11. Assist the safety crew to re-float the boat by getting out if required by safety crew. Once back in the water, ensure that you have permission from the safety crew before you restart your engine and move back to the pits. Once re-started, drive back to the pit pool by the shortest route to the finish line at a speed only fast enough to prevent further grounding in shallow channels. Boats may not return to the pit pool via the start line channel unless indicated by the starter.

**PENALTY:** failure to comply DNF for next round.

12. If the tow-craft is called for, but then not required, the boat may not proceed to the pits until the tow-craft has been turned around and returned to the pit pool. If a dangerous incident is created a penalty will be imposed. Once re-started, a crew may not continue to drive the rest of the course as practice.

**PENALTY:** DNF for the next round.

13. Whilst racing, a boat may not pass through the finish line at any time other than at the conclusion of it's run.

**PENALTY:** DNF

14. During a run, if a crew notice any dangerous circumstance, distraction or an unusual object in the track, eg. a floating tyre, they can abort their run by slowing down, raising an arm and immediately

returning to the finish via the quickest and safest route. If the safety crew can verify that there is an obstacle they will remove it and the crew will be allowed to re-start. The race controller is to decide on circumstance or unfair distraction. This allowance may not be misused to compensate for a bad run.

**PENALTY:** If no obstacle or circumstance or unfair distraction found- no re-run and DNF.

15. In the event of no primary or back-up time being recorded by the timekeepers for a particular run, that crew will be allowed a second run, which should be made as soon as possible and may be added to the next round. If a boat is unable to make a re-run due to mechanical problems, then it's previous best time at that meeting and on that track direction, will be recorded.
16. Once a crew has made their first run of the day they may not change their roles, that is, a driver cannot change places with the navigator. In the event of a crew member being unable to continue racing due to illness or injury and at the discretion of the sprint controller, substitute crew may be used provided that:

The substitute driver; May having completed all pre-competition formalities and already a competitor on the day can race another boat providing he/she is able to complete at least one qualifying round before commencing the elimination rounds. Any previous times recorded by that driver will be disregarded.

Once eliminations have commenced, a substitute navigator may be used, but only from a previously eliminated crew and only after it is established that the previous navigator is unable to continue. A driver may not be substituted once eliminations have commenced.

**PENALTY:** Role changes or unauthorised substitution of crew: disqualification for the remaining rounds.

17. A crew must be ready to start in the correct running order in each round. If there is a problem, the starter or pit Marshal must be notified of the problem in advance of their start order. If sufficient notification is given, the crew will be allowed to start later in that round.

18. In the case of a “B” crew near the end of the running order, they will be allowed a start in the following round, with their time counting for the previous round.
19. If a problem with a boat occurs in a qualifying round, there is a two-minute time limit upon repairs. This time limit will commence from when the last boat in that particular round enters the pit pool at the conclusion of its run and the time will be displayed on the main timing system display (where practical). The time count ceases when the subject boat is moving toward the start line, under its own power, with both crew on board, all safety equipment in place and under control of the starter. From the top16 down, the time limit shall be ten minutes and will apply from the time the affected boat is due to start in order, other boats will continue to race until the time has elapsed. If the affected boat cannot continue after ten minutes has elapsed, the timer will record a DNS. (The time count ceases when the subject boat is moving toward the start line under its own power ready to race). The sprint controller will be responsible for keeping time in this instance. At all times, the pit marshal or starter must be kept informed as to the status of the boat. A time-out is declared if the scrutineer is required to inspect a damaged boat and he/she must be completely satisfied that the boat is safe and fit for racing. No further work may be carried out during a scrutineering “time out”.

PENALTY: Not notifying Pit Marshal or Starter of a problem or an inability to start in order - DNS.

PENALTY: Exceeding the two or ten minute time limits - DNS.

19.1 In the event that a Dummy grid is to be used to stage boats for launching, the boats must be at the dummy grid within 5 minutes of their “Last Call”. In the event that a crew notifies the race controller of a problem with their boat they will make good their repairs within the allocated time frame (see rule 19) at the dummy grid under the supervision of the race controller or his steward without impedence to any other crew.

20. Any boat, which suffers a heavy impact or obvious damage in a racing accident, must be re-scrutineered before further competition. The re-scrutineering process will take place after any work to repair

damage to the boat has been completed, but shall have time constraints such as meeting the appropriate time limits or qualifying rounds. The boat may not be returned to the water until the scrutineer has declared it safe for competition. In the absence of a scrutineer the sprint controller will re-scrutineer the boat. Likewise, the crew must be checked by the ambulance or first aid crew and declared fit to resume racing.

21. On race day, there will be a minimum of two (2) qualifying rounds, but normally three. If the qualifying rounds are reduced for any reason once racing has begun, the first elimination will include all entrants affected. (Elimination rules apply to such rounds). Formation of the elimination rounds will be advised on the event programme, or at drivers briefing. The cut progression will be advised prior to the running of that segment, but will normally be 16-8-4-2. The running order from the top 8 down must be slowest first. Where there are insufficient numbers to make up an elimination round, the round will still be treated as such, until the relevant cut can be made. (Elimination rules apply to such rounds).
22. Due to a number of variables such as weather, accidents, crew and boat numbers, the sprint controller retains the right to vary the progression of the elimination cuts. Crews will be informed of variations in advance.
23. Regardless of the number of crews available, no crew may be included in the elimination rounds without recording a qualifying time.
24. During the eliminations, if two crews record equal times in a particular round and that time qualifies for the last spot in the next round, they shall both be included in that next round, even though it adds an extra boat to that round. The following cut however, will be as previously established.
25. In the elimination rounds, if more than one crew records a DNF in any elimination round, their respective positions in that round will be considered equal. In all instances, a DNF will score higher than a DNS.

26. In the top 2, if both crews record equal times they shall have a run-off in the same order as before, to determine the winner. If necessary, this process shall be repeated until a result is achieved.

## **902 - NEW RULES FOR CIRCUIT ENDURANCE CHAMPIONSHIPS**

### **1. ORGANISATION**

All races will be controlled by and remain the property of the U.I.M. In cases where International regulations do not exist then the national authorities will judge according to the general spirit of the event, considering U.I.M. circuit rules in groups 100, 200, 300 and 400. Any local rules must be accepted by the teams provided they are in the advance programme. The World Championship will be run over 4 events maximum with the possible addition of a 5<sup>th</sup> round, if this one is outside Europe, except pneumatics.

### **2. THE CIRCUIT**

The overall shape of the circuit is not binding but must not be less than 2500 metres, and a maximum of 6100 metres. All circuits must be registered with their N/A and with the U.I.M. (Min. 3 months prior to a race.) The turn buoys will be divided into each class so as not to have boats in different classes turning on the same turn buoy. For the catamaran classes, 2 distinct circuits will be set up, exterior circuit for Class I up to 1050 ccs and interior circuit for Classes II and III. There must be at least 750 metres between the main turn buoy.

For Pneumatics: The overall length of circuit must not be less than 1500 metres. The turn buoys for all classes will be the same. There must be at least 500 metres between the main turn buoy.



### 3. CLASSES

Catamarans classes: There will be three classes for the World Championship, based on the corresponding S classes.

Class 1. Up to 1050cc

Class 2. Over 1050cc and up to 2050cc

Class 3. Over 2050cc and up to 3100cc

Engines that comply with EPA regulations will be allowed to compete with a 30% greater capacity in their corresponding classes.

V Classes: There will be 2 classes for the World Championship.

Class 1. Up to 1050cc

Class 2. Over 1050cc and up to 3100cc

Pneumatics classes: There will be 5 classes for the World Championship.

Class 1. Up to 770 cc

Class 2. Over 770 cc and up to 1060 cc

Class 3. Over 1060 cc and up to 1550 cc

Class 4. Over 1550 cc and up to 2050 cc

Class 5. Over 2050 cc and up to 3150 cc

Engines that comply with EPA regulations will be allowed to compete with a 30% greater capacity in their corresponding classes.

V classes and pneumatics must NOT run with Catamarans.

Additional provisional classes for 2008 for low emission engines complying with 2006 EPA rules (as per homologation sheet) for pneumatics :

PR 60 HP Horse-power of the engine not more than 60

PR 115 HP Horse-power of the engine not more than 115

PR 200 HP Horse-power of the engine not more than 200

PR  $\infty$  Horse-power of the engine - unlimited

The races in these classes are run along with conventional classes. The classification can only be established if there is a minimum of 5 entries per event per provisional class. The organizer must provide the equipment necessary to confirm the power rating of the engine in accordance with U.I.M. / Engine manufacturer recommendations, otherwise there will be no classification in provisional classes.

## **4. DURATION**

The race will be for a minimum time period of 6 hours and maximum time of 24 hours continuous racing (see Part 17 also).

## **5. ENTRIES**

All entries must be on the organising club's official form and entries must be sent in by the date as requested. Late entries may be accepted providing all paperwork is in order and that their inclusion does not affect the water capacity as homologated. Entry fee for the championship may be charged. Late entries may be fined.

## **6. VALIDITY OF DRIVERS**

All drivers must be in possession of a current licence issued by his N/A for the class of boat that he wishes to race. He must also have the N/A permission to race. All other aspects refer to IUM rule 120. A driver must also have a current immersion test certificate if required by the U.I.M. for that class.

## **7. INSURANCE**

Any driver who does not carry insurance to meet the requirement of the country in which they are racing, will have to pay, per boat, the required amount to a maximum of 190 Euros.

## 8. TEAMS

For races up to 12 hours there must be a minimum of two pilots and a maximum of 4 pilots, and for races from 12 hours to 24 hours there will be a minimum of 3 pilots and a maximum of 4 pilots **and 5 pilots for the Class 1**. Teams may practice more than the required number of pilots providing they have all paper work and licences in order. Team managers must notify the Control, 1 hour prior to the race as to their final pilots names and no alteration of the pilots list will be accepted for whatever reason. Failure to do so will lead to D/Q of the team. A pilot must not drive continuously for more than 2 hours. Any laps over the period will not be included. Minimum rest period for drivers is one hour.

## 9. TEAM MANAGERS

All entries must have a Team Manager who must not be a pilot. In a case where there is more than one boat in a team then the Manager can represent all entries in that team. All penalties and other race documentation at the race site will be forwarded to the Team Manager. The Team Manager must be present at all meetings and scrutineering.

## 10. ADVANCE PROGRAMME

The organisers of the race will forward the advance regulations to all N/A's in English and their own language within 48 days of such race. All aspects of the advance regulations will have at least all those details as listed in U.I.M. rule 202.

## 11. DRIVERS MEETING

It is mandatory for all drivers and Team Managers to attend driver's briefing. It will be in English and the language of the majority of the drivers present and held after scrutineering and at least one hour prior to practice.

## 12. PRACTICE

All new pilots to the course must complete at least 2 laps of practice.

## 13. STARTS

The start will be a flying start behind a pace boat. The signal to start will be via a Green flag.

## 14. FINISHES

The finish of the race will be after the lead boat has completed the time duration. This will be denoted by a chequered flag flown from control and the final positions will be at the time the other boats complete the required time period.

## 15. CLASSIFICATION

To be classified as a finisher and to gain points you must have completed at least 40% of the class winner's laps and take the chequered flag. Boats not running but complete at least 90% of the class winners distance will be scored after all boats that take the chequered flag.

## 16. POINTS

Points will be awarded in each competing class as follows

1st	20	9th	7
2nd	17	10th	6
3rd	15	11th	5
4th	13	12th	4
5th	11	13th	3
6th	10	14th	2
7th	9	15th and onwards	1
8th	8		

## **17. INTERRUPTED RACE**

A race that has to be curtailed for one reason or another and it is impossible for the race to recommence then points will be awarded as follows:

Up to 25% of race time 20% of points,

40% of race time 50% of points,

60% of race time 75% of points,

90% of race time 90% of points,

Over 90% full points.

If a race is interrupted and can be recommenced within a reasonable period of time then the recommencement procedure will be as the start of the race less completed time. The time period remaining will be the total race time less 15 minutes and less completed time. The distance covered by each part of the race will be added together for the final result. The distance covered, the lap prior to the stoppage will be the laps taken. If the race has to be brought under a reduced speed then the pace boat will take the boats round in order there will be no overtaking. The restart will from the pace boat.

## **18. REPAIRS**

All repairs must be carried out within your designated pit area.

## **19. FUEL**

Fuel for racing must be provided by the organisers to a minimum standard of 95 RON Unleaded fuel. All competitors must use the fuel supplied by the organisers at cost as indicated in the advance programme, any competitor failing to use this fuel will be disqualified. No race fuel can be stored at the boat pit position. All boats must be refuelled at the fuelling depot. Each pit area may have a maximum of 25 litres stored in a shock proof container and carry the race number of the boat. The sole purpose of this is for generators etc. and must not be used for

the race boats except in the case where repairs to a boat necessitate the fuel tank being drained. In this case a max of 25 litres may be placed into the fuel tank of the boat to fire up the engine in the pits and to drive the boat to the refuelling station. The maximum amount of fuel that a boat can carry is 200 litres for Catamarans and 100 litres for V. Boats

The use of replaceable plastic tanks for fuel with the capacity of no more than 50 litres is allowed for Pneumatics.

For Pneumatics the maximum amount of fuel the boat can carry is as follows:

CLASS 1	60 liters
CLASS 2	100 liters
CLASS 3	150 liters
CLASS 4	200 liters
CLASS 5	200 liters

## **20. REFUELLING**

Must be carried out at the refuelling station and with the engine off. No repairs of any kind can be undertaken at the refuelling point.

## **21. FUEL DEPOT**

All personnel entering the fuel depot must not carry the following: Cameras: Mobile Phones: Electrical items: Metal Objects: any device that can be ignited i.e. Lighters. All personnel must have rubber soled shoes.

## **22. PENALTIES**

Any sanction against a driver (Yellow cards or disqualification) will be reported to the U.I.M. Should a driver be disqualified from that event under any rules of the U.I.M. then the team may continue providing they

have the minimum number of drivers. All other penalties will be reported to the Team Manager and displayed at race control.

Fuel infringement	8 laps
Race infringements	5 laps
Light infringements	(after 2 laps of notification) no laps will be scored.
Craning infringements	8 laps
Failure to attend scrutineering or drivers briefing	5 laps
Flag Infringement	5 laps
Priority of boats	5 laps

## 23. PROTESTS

The Team Manager on behalf of his driver can make a protest. No collective protests will be accepted. They must be written in English with full details and, if appropriate the U.I.M. rule. The fee for a protest is fixed at 150 Euros, and for a protest against an engine is fixed at 380 Euros. Protest will be heard if possible within one hour of the protest being accepted and the result of any such protest will be given to the Team Manager and driver if possible. If a protest is upheld and laps have been deducted at the next posting of positions the laps will be re - introduced. If a protest comes within the last hour of racing then the protest will be heard as soon as possible and the final result will be not be posted until the protest has been heard. Protest on the final results must be made within half of one hour.

## 24. YELLOW/RED CARDS

Yellow cards can only be given by the O.O.D. or the U.I.M. commissioner for offences on the water. They must be issued to the Team Manager or the driver on the official U.I.M. form. Other offences are covered within rule 406.06 of the U.I.M.

## **25. APPEALS**

Appeals against any protest not upheld see U.I.M. rule 405.

## **26. POSTING OF POSITIONS**

Positions will be posted every half hour for the first 2 hours then hourly and every half hour for the last 2 hours.

## **27. BOATS BROKEN DOWN ON COURSE**

Any boat that breaks down on the course cannot refuse a tow and must be towed in the direction of the course, unless derogation is granted, if the width of the water level allows this tow in full safety. This must be specified on the advance program. It is forbidden to be towed against the race direction on the race course.

## **28. PRIORITY OF BOATS**

Rescue and pace boats have priority at all times. Entering the pit land and refuelling lane must be done at reduced speed and no overtaking unless a boat has become stationary. All boats entering the pits or refuelling area have priority over those departing.

## **29. RESCUE**

There must be at least one rescue boat for every 250 metres of course and that the course must be visible at all times from at least two rescue boats. There must be at least one rescue boat every 1000 metres capable of carrying a stretcher or that the boat must be a drop front dory.

## **30. SCRUTINEERING**

All boats must be scrutineered before entering the water. It is mandatory for all drivers to be present and the Team Manager. All drivers must be able to prove that they fit within the craft as per U.I.M. rules. The O.O.D.



and U.I.M. commissioner will rule upon any such cases that infringe U.I.M. rules on cockpits. Each pilot must have his own helmet and life support vest and this must be produced at scrutineering. All boats must be presented to scrutineers with pickle forks dismantled and boats must have a spare pair that must be presented to the scrutineers.

## **31. CRANES**

In the event of a crane being used for launching there will be a minimum of one crane per 15 boats. If launching is by slipway then one launch vehicle per 15 boats. The slipway must be large enough to allow the number of launch vehicles to work at the same time.

## **32. FLAGS**

Red: Race terminated return to the holding area and await instructions

Yellow: Danger on circuit,

Black: With race number fixed - driver to return immediately to the pits,

Chequered black & white: Race completed,

Yellow: Pace boat on circuit - no overtaking and reduce speed,

Green: Race commenced/recommenced.

## **33. TURN BUOYS**

Turn buoys will be of a single colour either Orange or Red unless there are turns of both left and right then for left hand turns the buoy will be Orange and for right hand turns the buoys will be yellow.

For hitting a turn buoy no penalty,

For dislodging or destroying the first turn buoy - 5 lap penalty,

For dislodging or destroying the second turn buoy - 10 lap penalty,

Destroying a turn buoy - the cost of replacement will be charged to the offending team. Maximum cost 200 Euros per buoy. Each turn will have 2 turn buoys.

### **34. POST INSPECTION**

The first three boats in each class will render themselves to the “parc ferme” for inspection immediately after the end of the race. Any boat failing to do so will be D/Q from that race. the only persons allowed in “parc ferme” are the drivers, the Team Manager and two mechanics. No other personnel are allowed.

### **35. MACHINERY**

Only homologated single engines can be used. The engine block must remain the same as started. All other parts may be changed. All engine blocks will be marked one hour prior to the commencement of the race. more than one engine can be used in practice.

Use of power trim is allowed for pneumatics. The height of the motor must remain fixed while racing for pneumatics.

### **36. HULL**

The hull as started is the only hull to be used. More than one hull can be used in practice providing it passes all scrutineering. Running repairs can be carried out to hulls at their own pit area. All repairs must be inspected by the scrutineers before re-entry to the race.

### **37. NAVIGATION LIGHTS**

Boats racing during night hours must have navigation lights as follows:

Single red to Starboard min 5 watt.

Single Green to port min 5 watt.

Two sets of white lights separate installed to the stern of the boat, minimum 5 watts each, with back-up batter supply.

2 spot light minimum to the front of the boat 36 watts minimum. These lights must not be more than 2 metres from the front of the boat. Drivers must carry a water-proof torch within the boat.

### **38. SLINGS**

Each boat must carry its slings at all times if launch is by crane, whilst on the water and must comply with the safety rules and regulations of rule 205.12 of the U.I.M. Drivers or mechanics must not ride in boats whilst the boat is being craned.

### **39. NATIONAL FLAGS**

All boats will carry the national flag of all competing drivers.

### **40. U.I.M. PENNANTS**

It is mandatory for all boats to carry the U.I.M. Logo to both side of the boat.

### **41. BUOYANCY**

All boats must carry sufficient buoyancy to keep their boat afloat.

### **42. FIXING EYE**

A reinforced cockpit boat must be fitted at the bow with two mooring eyes, one at the top and one at the bottom, eye not less than 25mm and not further than 250mm from the front. The fixing shall be strong enough to tow a boat partially submerged. A tow rope must be fixed. It must not be longer than the length of the hull.

## **43. PUBLICITY**

The organising club and national authority can request that any offences advertising or any that conflicts with the sponsor or sponsors may request it to be covered throughout the duration of the race. All other aspects - see rule 203.051.

## **44. MEDICAL COVER**

The minimum cover for the duration of the race and practice is for two ambulances on station at all times and two doctors, one to be trauma trained. It is advisable to have two stations.

## **45. DRUG TESTING**

All drivers can be subjected to drug and alcohol tests. Any refusal will be deemed as a failure and the drive disqualified. Any tests that prove positive, the drive will be disqualified and reported to the U.I.M. All other aspects - see rule 205.02.02.

## **46. PRIZES**

The U.I.M. will provide Gold, Silver and Bronze medals at the completion of the series of races and the Champions will receive their medals at the last race. The organisers will provide trophies for the first three in each U.I.M. class at each event. Prize giving must be within one hour of the completion of the race or, if protests are being conducted then it will be 30 minutes from completion of protests.

## **47. RESULTS**

The results will be forwarded to the U.I.M. offices within 24 hours of the completion of the event.

The general classification will be drawn on additional points of all rounds per pilot(s).

In case of an ex æquo the points obtained in the longest endurance race will determine the winner(s) (there could be various ex æquo positions if it concerns one same team).

In all events, the pilots will be classified and not the boats.

## **48. U.I.M. COMMISSIONER**

A U.I.M. Commissioner will be present throughout the event and the costs will be borne by the organising club. The club must make Hotel arrangements for all the nights that the Commissioner will be present. For events of more than 12 hours, 2 Commissioners will attend, one of which is the Senior. The U.I.M. will decide on seniority.

## **49. PACE BOAT**

It is mandatory that a pace boat be launched ready for use throughout the duration of the event and should there be a need for the race to be brought to a much reduced speed, then the pace boat will lead the leading boat flying a yellow flag until such time as the course is clear to race. All boats must remain in the order that they are in with no overtaking permitted. When the race is due to be restarted the yellow flag will be dropped and the green flag raised. When the pace boat marshal is happy that all is in order to restart he will drop the green flag. This is the only signal to recommence racing.

## **50. RACE NUMBERS**

In the event that two numbers are identical, then the team who enter first can keep their race number. The Scrutineer will issue a further number to the Team and it is the team's responsibility to replace the number. Race numbers must be on the race trailer. An organised will, if possible, notify any team of a clash of numbers prior to scrutineering. Number one is reserved for the winner of the U.I.M. world championship. For all night races the numbers must be in luminescent white on a black background 40 x 40. All numbers must be fixed to both sides of the boat on the cell,

for Catamarans only, just behind the drivers head position. For V. Boats the number must be vertical and behind the drivers head.

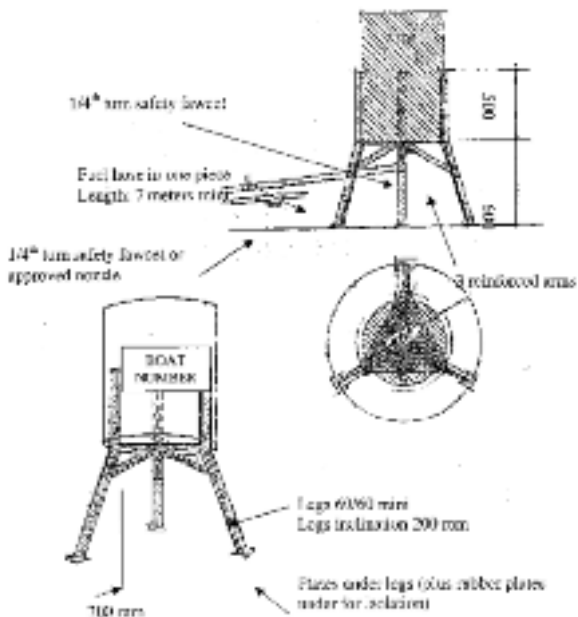

## **903 - GRAND PRIX HYDROPLANE CLASS**

### **GENERAL**

These rules are intended to provide specific requirements relating to the Grand Prix Hydroplane class. Otherwise the general rules of the U.I.M.

Circuit rulebook and the Race Organiser apply. Class designation letters shall be “GP”.

## **903.1 - HULL**

### **903.1.1 - DIMENSIONS**

This class shall be for hulls of the hydroplane type with a minimum length of 6.4 m (21 ft) excluding projections that are not part of the original hull. Maximum boat size shall be 8 m (26 ft) long x 3.96 m (13 ft) wide. There shall be no maximum width for the tunnel. The “box style” method of measurement must be used. i.e., the boat plus all projections must fit into a rectangular “box” 8 m long x 3.96 m wide. No monotype hulls will be accepted.

### **903.1.2 - WEIGHT**

The minimum weight for boats in this class shall be 1032 kg (2275 lbs) for normally aspirated engines and 1123 kg (2475 lbs) for boats using a supercharger. These weights shall be measured when a boat finishes a heat. Boats must have all compartments drained of water. The residual fuel, oil, etc. is permitted.

### **903.1.3 - COCKPIT AND CANOPY**

All Grand Prix boats must have a reinforced cockpit and full canopy built to U.I.M. specifications. A working escape hatch on all boats built after 2005 must also be provided.

## **903.2 - ENGINES AND DRIVE SYSTEMS**

### **903.2.1**

Engines shall be automotive or marine, cast iron or aluminium, 4 cycle, 2 valve per cylinder, internal combustion type with a maximum displacement of 8.4 litres (513 C.I.D) with no allowance for over size. Superchargers and turbochargers are allowed without displacement

penalty. Engines under 6.4 litres (392 C.I.D) must be supercharged. After market engine blocks are acceptable. A single speed gear box (transmission) is allowed. No multiple speed gear boxes are permitted.

### **903.2.2 - FUEL SHUT-OFF DEVICE**

A positive fuel and/or electrical shut-off switch must be fitted to the left hand side of the cockpit and be suitably identified.

### **903.2.3 - DRIVE**

Propulsion must be by one underwater propeller. Out drives are not permitted. Cavitation plates and drive shafts shall not be adjustable while boat is underway, however aerodynamic wings may be. All rudders, rudder brackets and skid fins must meet the Grand Prix organiser's standards of integrity and must be inspected by the technical inspector(s) prior to every event.

### **903.2.4 - RUDDERS**

The hardware material for rudders is to be stainless steel heat treated # 17-4 or better. Skid fins (and rudders) are required to be minimum 19 mm (3/4") aluminium # 7075 or heat treated 4140 or 4130 steel. Brackets as a minimum must be made from # 6061 or # 7075 aluminium. Stainless steel # 17-4 and steel # 4130 may also be used. Also alloy 2024 # T351 has good elongation and ductility of high grade aluminium, comprises of copper - magnesium -manganese alloy may be used.

### **903.2.5 - FIRE SUPPRESSION**

All Grand Prix boats shall be equipped with a functional on-board compressed gas or equivalent foam fire suppression system with distribution nozzles in the engine compartment, half of which must be discharged in front of the engine. The minimum weight shall be 3.0 kg capacity. The system must include a manual triggering device operable by the driver on-board the boat or by a helper outside. The location of the outside device must be indicated by the "E" in a red circle. The system



shall be inspected and approved by the technical inspector(s). Exceptions to this rule shall only apply to non-GP class boats or Series boats running with GP class boats in a GP class event, as long as the non-GP class boats meet the fire suppression rules of their particular class or series. Each boat trailer in the working pit shall have a minimum of 3.0 kg capacity dry chemical approved fire extinguisher available for easy access.

## **903.3 - INSPECTION OF BOATS AND ENGINES**

### **903.3.1**

No boat shall be allowed to start in a GP class event until its hull and engine(s) have been inspected for compliance of all rules pertaining to safety and eligibility. A Measurement Certificate issued by the National Authority must be produced at inspection.

### **903.3.2 - SEALING OF ENGINES**

All engines, following inspection, must be sealed using the following procedure; engines shall be legibly numbered in an accessible location on the block and a hole drilled in an accessible webbing for attachment of an identification seal.

### **903.3.3 - RANDOM CHECKING**

Engines may be randomly checked at any time to determine maximum capacity and other eligibility.

## **903.4 - CONDUCT OF RACES (RECOMMENDED FORMAT)**

### **903.4.1**

Recommended formats are closed course time trials and multiple heats of 3 or 4 laps over a 1-1/4 mile course, except where it is confirmed impossible or impractical by the race committee. Course size must be

registered with the Grand Prix Club thirty (30) days before a race and remain unchanged. A Minimum of 1 hour must be allowed between heats where the same boats compete. In all qualifications and finals, lanes must be established approximately 150 m (500 ft) (marked by a buoy) before the entrance of the upper turn.

### **903.4.2 - DAY ONE**

The first day of racing will consist of time trials and one set (heat 1A and 1B) of competition heats. Competition heats will be three (3) laps. A minimum of two hours must be allowed between the completion of the time trials and the competition heats. Competition in these heats will be formulated per the Grand Prix referees' agreement with the local race director.

### **903.4.3 - DAY TWO**

The second day of racing will consist of time trials, one set (heat 2A and 2B) of competition heats, semi-final and final event. Competition heats will be three (3) laps. A minimum of two hours must be allowed between the completion of the time trials and the competition heats. Competition in these heats will be formulated per the Grand Prix referees' agreement with the local race director.

### **903.4.4 - SEMI-FINAL EVENT**

The semi-final will be held a minimum of two hours after the completion of the competition heats. Places seven (7) through fourteen (14) from the time trials will compete in this event. Lane choice will be determined by a draw from a hat. This will be conducted by a member of the Race Committee. The seventh, eighth and ninth qualifiers from the time trials will draw for lanes, one two and three. Seventh place will have first draw. The tenth, eleventh and twelfth qualifiers will draw lanes, four, five and six. The first and second place boats from the semi-final qualify for the final event as trailers. The remaining finishers from the semi-final are on standby for the final.

### **903.4.5 - FINAL EVENT**

The top six (6) qualifiers from the time trials qualify for the final. Lane choice will be determined by a draw from a hat. The first, second and third qualifiers from the time trials will draw for lanes one, two and three. First place qualifier will have first draw. The fourth, fifth and sixth qualifiers will draw for lanes four, five and six. The two remaining positions for the final will be the inside and outside trailers. Trailers' positions are rewarded based on their order of finish from the semi-final event.

### **903.4.6 - STAND-BY ENTRIES**

Stand-by entries shall be allowed and be classed in the order of performance provided they have completed one (1) lap in the qualifying heats. The stand-by entries will be notified by the Referee before the five (5) minute signal if eligible to race.

If a stand-by boat gets into the final, Grand Prix will pay the boat he replaced 8<sup>th</sup> place prize money. "Stand-by" entries shall be allowed and be classified in the order of performance. No stand-by boat in the water. If requested by the members and if time permits, a five minute-to-the-five warning may be given by the Referee prior to the start of all heats. The number of boats in the water at one time shall not exceed the available docking.

### **903.4.7 - FINISH OF RACE**

Once the lead boat receives the chequered flag, all boats will be considered as having completed the race when they receive the chequered flag at their next crossing of the start/finish line.

### **903.4.8 - COURSE INFRACTIONS**

For safety reasons, boats may cross the starting line before the last thirty (30) seconds prior to the official start of the race. All boats crossing the starting line during the last thirty (30) seconds before the official start will be assessed a two (2) minute penalty.

Holding/changing lanes: All competitors must hold their assigned lane through the completed first turn of the first lap of competition. Changing of lanes cannot occur until the boat has passed the second buoy (exit pin from the first turn) and the six boat minimum requirement is met.

### **903.4.9 - PRIZE MONEY**

Prize money and points will be awarded as scheduled in the Advance Programme.

Drivers and/or owner or one of their representatives must be present at the event prize giving function.

### **903.4.10 - BACK-UP BOAT**

A driver may accumulate points with only one boat per event.

## **903.5 - DRIVER REQUIREMENTS**

### **903.5.1 - IMMERSION CERTIFICATE**

All drivers must hold a current certificate of underwater training as outlined in rule 205.05.

### **903.5.2 - DRIVER APPROVAL**

Any driver who drives a boat for the first time in competition shall not hold the pole position at the start and first turn in at least one heat. The referee shall appraise his performance and, if satisfactory, waive further restrictions.

### **903.5.3 - LICENSE**

Final approval of all drivers shall rest with the decision of the driver's National Authority. The Driver's National Authority must confirm the status of each driver in written format. A copy of all activities for each driver will be maintained with the Race Committee.

### **903.5.4 - MEDICAL**

All drivers must have an annual medical examination as determined in Rule 205.01 including an electro cardiogram performed under stress as per the requirements for a Super Licence determined in Rule 205.04.1

### **903.5.5 - CLOTHING PROTECTION**

It is mandatory for all drivers to wear protective clothing as determined in Rule 205.11. Such clothing must have tight fitting cuffs and ankles and also have fire retardant properties. Gloves shall also be worn.

### **903.5.6 - CONSUMPTION OF ALCOHOL**

The consumption or use of any alcohol in the working paddock or pit areas shall be expressly prohibited until after 30 minutes after the last heat of the day or inspection is completed, which ever is later. Specifically, drivers shall conform to Rule 205.02.02 regarding doping test and consumption of alcohol.

## **904 - INBOARD RACING DISPLACEMENT CLASS RULES**

### **1. CLASSES**

RD  $\infty$  cylinder capacity of motor to infinity.

### **2. HULL**

The hull shall be displacement or monoplane type in which the continuity of the portion of the hull immersed, at rest, in racing trim with the driver on board, shall not be interrupted longitudinally or transversely by any form of break, step or device of construction or hydrofoil, that would provide multiple planing surfaces. Hulls are permitted to be either mono V hulls or flat bottom hulls.

Cockpits [rule 509]. All new hulls built after **1<sup>st</sup> January 2011** must be fitted with a reinforced cockpit with a minimum strength of **5000** newtons.

All existing hulls must have a reinforced cockpit to the above specification fitted by **1<sup>st</sup> January 2011**.

The term hull shall include all additions and attachments below the waterline with the exception of the shaft, strut, propeller, rudder, fin and such that are usual and necessary. Cavitation plate, trim tabs and after planes that are fixed or adjustable whilst underway shall be permitted.

Lap strake or reverse lap strake construction may be used provided the immersed portion of the strakes (planks) be approximately parallel with the centre line of the hull and the depth of the strake (plank) be no greater than 35mm.

Planing strakes (planks) unless continuing to the tuck (transom) must finish on an angle being not less than 450mm from the point of commencement of the angle to flush with the hull bottom and the angles not to be concave to the hull bottom.

Non-trip chines with a rise of not less than 75mm in 300mm, vertical sided keels and skid fins shall be allowed.

At the option of the owner or the builder, that point where the planking meets the non-trip chine can be rounded or left square regardless of the thickness of the planking.

The depth (thickness) of the strake (plank) is to be taken by stretching a wire or similar material around the bottom of the hull, at right angles to the centre-line, on the point being measured.

The depth (thickness) is to be measured at right angles to the hull surface and this depth must not be more than 35mm at any point.

### **3. WINGS**

Only Infinity class hulls fitted with forced induction (blown/supercharged) engines are permitted to use wings.

Only single or dual plane wings are permitted.

All wings must be mounted directly to the engine or the engine bearers.

The wing including the side fins/spill plates should be a maximum of 450mm higher than the highest point of the boat or engine and must not extend beyond the extremities of the hull at the mounting point.

The suitability and adequacy of the wing is the responsibility of the owner, who should be satisfied that it is competently designed, manufactured and fitted so as to remain fixed and operational at high speeds.

The wing *may* be adjustable while the boat is in motion.

#### 4. MINIMUM DIMENSIONS

CLASS	Weight	Length	Reinforced Cockpit
RD $\infty$	TBA	5.2 M	<b><i>Mandatory 1<sup>st</sup> January 2011 [5,000 Newtons]</i></b>

The length must be measured between perpendiculars at the foremost and aftmost rigid part of the hull.

Any extending parts such as rubbing strakes, fenders, stabilising or trim tabs, rudder, skeg or cavitation plate, are not to be included in the length measurement.

The minimum weights mentioned here are the weight of a complete rig weighed directly after the race including driver, personal safety equipment, residual fuel but without residual water.

#### 5. MACHINERY (CLASS RD)

It must be a piston engine not turbine.

The motor must be fixed inside the hull.

The power transmission train must pass through the structure of the hull.

All modifications are allowed.

All propelling forces must be directed in and against the water.

An electric starter and battery must be on board.

The transmission is free.

## **6. FUEL**

The type of fuel will be Gasoline or Methanol/Ethanol.

Nitrous oxide will be permitted. Nitro Methane and any other chemical supercharging will not be permitted.



## **905 - HYDRO SPRINT RULES**

This regulation is intended to provide for specific matters related to the method and rules of motorboat racing conducted by those organizers appointed to by Hydro Sprint International Ltd (H.S.I.)

The Hydro Sprint rules are originated from the Korean style motorboat racing, run by Seoul Olympic Sports Promotion Foundation.

### Chapter 1. General Provisions

Article 1 (Purpose)

Article 2 (Definition)

### Chapter 2. The Operation of Motorboat Races

#### Section 1. Motorboat Racing

Article 3 (Race Notification)

Article 4 (The Number of Races)

Article 5 (The Types of Races)

Article 6 (Racing Distances)

Article 7 (Members of the Racing Operation Council)

#### Section 2. Application to Participate in Motorboat Racing

Article 8 (Application)

Article 9 (Notice of Acceptance)

Article 10 (Cancellation of Application)

#### Section 3. Inspection and Confirmation of Qualifications

Article 11 (Confirmation of Qualifications)

Article 12 (Confirmation Inspection)

Article 13 (Confirmation of Drivers, Boats, and Motors)

Article 14 (Inspection Before Start)

Article 15 (Cancellation of Racing)

#### Section 4. Organization of Racing Schedules

Article 16 (Organization of Racing Schedules)

Article 17 (Announcement of Racing Schedules)

#### Section 5. Drivers and Motorboats

Article 18 (Motorboat)

Article 18-1 (Racing Attire)

Article 19 (Registration Number Plates)

Article 20 (Fuel and Lubricator)

## Section 6. Securing Fairness on Races

- Article 21 (Motorboat Racing Sanction Deliberation Committee)
- Article 22 (The Kinds of Sanctions)
- Article 23 (Banning/Suspension of Being Involved in Races)
- Article 24 (Suspension of Participating in Races)
- Article 25 (Written Warning and Caution)
- Article 26 (Report of Facts)
- Article 27 (Decision on Sanctions)
- Article 28 (Formal Objection)
- Article 29 (Objection Processing)

## Section 7. Motorboat Racing Judging Methods

- Article 30 (Aim of Decision)
- Article 31 (Three Factors of a Judge's Decision)
- Article 32 (Judge's Decision Standards)

## Section 8. Awards for drivers - see H.S.I. Handbook

## Section 9. Admission Fee and Public order - see H.S.I. Handbook

## Section 10. Winner voting and Betting System - see H.S.I. Handbook

# Chapter 3. Racing Rules

## Section 1. General Regulations

- Article 33 (Racing Method)
- Article 34 (Definition of Glossaries)
- Article 35 (Waiting for Racing)
- Article 36 (Exclusion from Racing)

## Section 2. Introduction Run

- Article 37 (Racing Method)
- Article 38 (Preparation for Racing)

## Section 3. Start

- Article 39 (Preparation for Start)
- Article 40 (Start Signal)
- Article 41 (Waiting Behavior)
- Article 42 (Effective Start)
- Article 43 (Announcement of Race Suspension/Disqualification)
- Article 44 (Confirmation of Finishing/Order)
- Article 45 (Detailed Regulations)

#### Section 4. Navigation

- Article 46 (Ban on Touching)
- Article 47 (Collision Avoidance)
- Article 48 (Changing Direction)
- Article 49 (Turn Mark Rotation)
- Article 50 (Passing)
- Article 51 (Others)

#### Section 5. Void Race and Disqualification of Racing

- Article 52 (Ineffective Race)
- Article 53 (Disqualification for Racing)
- Article 54 (Disqualification)
- Article 55 (Investigation into Accidents)

(Appendix 1)

Acknowledgement and agreement of U.I.M. Anti Doping Rules

(Appendix 2)

Operation Rules of Sanction Deliberation Committee

#### Chapter 1. General Provisions

- Article 1 (Purpose)
- Article 2 (Applicable Scope)

#### Chapter 2. Motorboat Racing Sanction Deliberation Committee

- Article 3 (Establishment and Composition)
- Article 4 (Convention)
- Article 5 (Decision-making)
- Article 6 (Agenda)
- Article 7 (Participation of the Motorboat Driver Subjected to a Sanction)

#### Chapter 3. Sanctions

- Article 8 (Application for Sanction and the Procedure Involved)
- Article 9 (Processing of a Sanction Procedure)
- Article 10 (Decision on a Sanction)
- Article 11 (Sanction Appreciation and Its Standards)
- Article 12 (Added Sanction)
- Article 13 (Reduced Sanction)

Chapter 4. Lodging an Appeal

Article 14 (Lodging an Appeal)

Article 15 (Re-deliberation)

Article 16 (Exclusion and Avoidance)

Article 17 (Effects of the Original Sanction)

Article 18 (Decision on Repairs)

Annexed Tables

Table 1 Members of the Racing Operation Council

Table 2 Medical criteria for Participating Drivers

Table 3 The standards of Boats and Motors

Table 4 Colors of racing uniforms and Motorboats in their  
Number

Table 5 Racing Course

(Annex Form 1) A List of the People Who Have Submitted a Written  
Apology

(Annex Form 2) Sanction Notice

(Annex Form 3) Application for an Appeal

# **U.I.M. HYDRO SPRINT RULES**

## **CHAPTER 1. GENERAL PROVISIONS**

### Article 1 (Purpose)

This regulation is intended to provide for specific matters related to the method and rules of motorboat racing conducted by those organizers (hereinafter called “organizer”) appointed to by Hydro Sprint International Ltd (H.S.I.)

### Article 2 (Definition)

The Hydro Sprint refers to a type of race, combining a race and a betting system together, contributing to governmental tax profits, activating local economy, providing thrills and satisfaction to the public involved, and so on.

## **CHAPTER 2. THE OPERATION OF MOTORBOAT RACES**

### Section 1. Motorboat Racing

#### Article 3 (Race Notification)

- a. If an organizer plans to hold a Hydro Sprint, it must announce its annual race schedule, including the following items, 20 days before the date of the first race:
  1. Racing places, dates, and times.
  2. The types of races, racing distances, and prizes on each racing date.
  3. The qualifications and application due dates of drivers.
  4. Others.
- b. The organizer may change or cancel the annual race schedule, which is specified in Article 3-a., in the case of an emergency, such as a natural disaster.

#### Article 4 (The Number of Races)

- a. The organizer can hold up to 15 races a day.

- b. A driver or a motorboat may participate in two races a day.
- c. A driver or a motorboat that participates in two races a day, must have an interval of more than two races between its designated races

#### Article 5 (The Types of Races)

- a. The organizer may hold the following two types of races:
  - 1. Online start races
  - 2. Flying start races
- b. The races specified in Article 5-a. must follow the racing rules in Chapter 3.

#### Article 6 (Racing Distances)

Racing distances must be 1,800 meters or longer.

#### Article 7 (Members of the Racing Operation Council)

- a. The organizer must have the following racing operators to hold a race.
  - 1. President of the Racing Operation Council
  - 2. Vice President
  - 3. Facility Managing Director
  - 4. Judging Director
  - 5. Fairness Controller
  - 6. Racing Operator
  - 7. Ticket Sales Managing Director
  - 8. Broadcasting Director
  - 9. Betting Shop Managing Director
  - 10. Driver & Motorboat Managing Director
- b. The Council members, composed of up to 20 people, may have assistants to help with their tasks.

- c. The Council members are the heads of the relevant departments (including team managers). If they are absent, the organizer may designate substitute members. Each operator's tasks are illustrated in Annexed Table1.
- d. If a Council member finds that his or her tasks are related to another operator's tasks, the member must immediately report to or inform the Director of the Racing Operation Council and the relevant operator.

## Section 2. Application to Participate in Motorboat Racing

### Article 8 (Application)

Those who want to participate in a motorboat race must submit the application form suggested by the organizer.

Only those drivers who have received a super license by the U.I.M. will be entitled to participate to the International Hydro Sprint Motorboat races.

The U.I.M. Super license will be issued upon receipt of

- Confirmation that the applicant fulfills all regulations as stated in the Hydro Sprint Management Regulations of the H.S.I. Handbook.
- ons based upon the world anti-doping code (form as per appendix 1 at the end of these rules).
- Receipt of the super license fee

### Article 9 (Notice of Acceptance)

When the applicant is accepted according to the regulations in Article 8, the organizer must immediately notify the applicant of the meeting place and time, and other requirements for the race by mailing an acceptance letter, or by phone or e-mail (including text message).

### Article 10 (Cancellation of Application)

- a. Those who want to cancel their application must give in writing the reason for the cancellation request, before receiving notice of

acceptance as specified in Article 9. If the reason is sickness, they must attach a medical certificate.

- b. After receiving notice of acceptance, applicants cannot cancel the application, unless the organizer changes the racing schedule or finds their reason as valid.

### Section 3. Inspection and Confirmation of Qualifications

#### Article 11 (Confirmation of Qualifications)

- a. Those who receive notice of acceptance, according to the regulations in Article 9, must go to the designated place by the specified date with the following items, and be confirmed their qualifications by the racing operator.
  1. Notice of acceptance, as specified in the regulations of Article 9
  2. Driver registration card and the official driver pocketbook
- b. Boats or motors to be used in the race will be chosen by drawing lots before the first racing date. If all the drivers participate in the lot, an electronic lottery method will be used, such as ARS(Automatic Reply System) or the Internet, or representative drivers will use a direct drawing method.
- c. If the driver cannot arrive by the designated date, as specified in Article 11-a, for a valid reason, the driver must notify a racing operator of the reason and an estimated time of arrival in advance, get approval from him, and follow his instructions.

#### Article 12 (Confirmation Inspection)

- a. Those who have confirmed their qualifications and had a motorboat assigned must get a confirmation inspection from the racing operators and judges, a day before the racing date, from the date they were admitted to attend each motorboat race.
- b. During the confirmation inspection, the racing operators must make a list of drivers who have passed the inspection, after they check racing aptitudes including physical condition, according to the physical checkup standards for drivers in Annexed Table 2.



- c. Selected Boats and motors must be checked to ensure they are safe and without structural defects, according to the Hydro Sprint management regulations (See H.S.I. Handbook). Then, motors must be installed in the selected boats. The boats and motors that have passed the final checkup while racing are attached with certificates.

#### Article 13 (Confirmation of Drivers, Boats, and Motors)

- a. The Racing operators and judges must confirm the drivers, boats, and motors that will participate in the races, according to the results of the confirmation inspection, make a confirmation list of them, and notify the operator in charge. Those who have obtained the approval of the racing operators, according to the regulations in Article 11-a., are confirmed as drivers.
- b. The drivers who have been confirmed participation in the races, according to the regulations in Article 13-a., cannot cancel their participation in the race, unless their reasons are found to be valid.

#### Article 14 (Inspection Before Start)

- a. The drivers, boats, and motors that have been confirmed as participating in the races must get to the waiting room an hour before the start time, and be inspected by the racing operators and judges.
- b. The racing operators and judges must check the following things when carrying out the inspection before the start, according to the regulations in Article 14-a.
  - 1. Whether or not, there are any changes since the confirmation inspection specified in Article 12
  - 2. Whether or not, If the conditions satisfy the regulations in Articles 18 and 20
- c. If the conditions at the time of the confirmation inspection need to be changed before the start, the changed conditions must be checked again through an inspection, which corresponds to the confirmation inspection.
- d. The drivers, who meet the conditions of the regulations in Article 11-a, but have not had their qualifications checked or had a confirmation

inspection, must have the relevant inspection, at the inspection before the start time, as specified in Article 14-a.

- e. The drivers, boats, and motors that participate in two races a day can get a collective inspection.

#### Article 15 (Cancellation of Racing)

The racing operators and judges may cancel the participation of drivers, boats, or motors, if they are expected to pose severe obstacles to the operation of the races, in relation to the regulations in Articles 12 and 14.

### Section 4. Organization of Racing Schedules

#### Article 16 (Organization of Racing Schedules)

The racing operators must assign a number to each race, and establish racing schedules for the drivers, boats, and motors that have been confirmed as participating in the races, according to the regulations in Article 13.

#### Article 17 (Announcement of Racing Schedules)

- a. After racing schedules are made according to the regulations in Article 16, the racing schedules must be announced in public.
- b. Drivers cannot raise objections to the racing schedules, which were established according to the regulations in Article 17-a.
- c. If drivers, boats, or motors are modified, after the racing schedules have been announced according to the regulations in Article 17-a, the modifications must be quickly made known at the appropriate places, including the racing place.

### Section 5. Drivers and Motorboats

#### Article 18 (Motorboat)

Types and specifications of motor and boat used in Hydro Sprint Races are illustrated in Annexed table 3

### Article 18-1 (Racing Attire)

- a. Drivers must wear the following attire:
  1. Racing uniform (A long-sleeved shirt and long pants)
  2. Helmet
  3. Life vest
  4. Protection pads and shoes
- b. The colors of racing uniforms and numbered motorboats are illustrated in Annexed Table 4.
- c. The organizer may allow drivers to display advertisements on their clothing.

### Article 19 (Registration Number Plates)

- a. Drivers must attach a set of registration number plates to their motorboats.
- b. The registration number plates must be positioned on both sides, in the middle of the motorboat deck.

### Article 20 (Fuel and Lubricator)

Drivers must use the fuel and lubricator specified by the organizer. If they mix them, they must follow the ratio that was decided by the organizer.

## Section 6. Securing Fairness on Races

### Article 21 (Motorboat Racing Sanction Deliberation Committee)

- a. In order to secure fairness in motorboat races, the organizer will establish a Motorboat Racing Sanction Deliberation Committee to examine and decide on applications for sanctions and objections.
- b. The organizer will decide on the composition and operation of the Motorboat Racing Sanction Deliberation Committee in detail.
- c. The operation rules of the Motorboat Racing Sanction Deliberation Committee is illustrated in appendix 2.

## Article 22 (The Kinds of Sanctions)

The organizer can take the following sanctions to ensure fairness in motorboat racing:

1. Sanction on being involved in races: The driver's registration is cancelled, and the driver is permanently banned from being involved in races or registering as a driver.
2. Suspension of being involved in races: The driver's registration is cancelled, and the driver is banned from being involved in races or registering as a driver for 1 to 5 years.
3. Suspension of participating in races: The driver is banned from participating in races for less than a year.
4. Written warning and caution: The driver receives a written warning or caution.

## Article 23 (Banning/Suspension of Being Involved in Races)

In the following cases, the organizer may ban or suspend the driver from being involved in races:

1. The driver forged or changed the application for the purpose of wrongdoing.
2. The driver did not exert competence to the maximum for the purpose of wrongdoing.
3. The driver received, requested, or promised assets or property interests to affect the fairness of the races.
4. The driver inflicted or tried to inflict damage on other drivers to affect the fairness of the races.
5. The driver provided or tried to provide a specific person with information on the results of the races.
6. The driver conspired over or signed an unfair agreement on the races.
7. The driver interfered with races or racing operators.

8. The driver disobeyed the racing operators' inquiry, judgment, or instructions.
9. The driver applies to Article 16-b of the Hydro Sprint Management Regulations in the H.S.I. Handbook.
10. The driver used banned substances for the purpose of wrongdoing.

#### Article 24 (Suspension of Participating in Races)

In the following cases, the organizer may suspend the driver from participating in races for less than a year:

1. The driver violated the regulations in Articles 10-b, 11, 12-a, 13-b, 14-a, 18, 19, or 20
2. The driver violated the regulations in Article 47 or 65.
3. The driver applies to Article 23-7 or 23-9 and committed a minor wrongdoing.
4. The driver violated the regulations in Article 26.
5. The driver did not exert competence to the maximum during the race.
6. The driver is considered to have conspired with other drivers in advance.
7. The driver is considered to have helped or interrupted other drivers during the race.
8. The driver is considered to have conducted an act that may provoke spectator suspicion during the race.
9. The driver is considered to have conducted an act that may provoke spectator suspicion during the introduction racing or while leaving after the race.
10. The driver is considered to have been negligently or passively involved in the race without any special reason.
11. The driver is considered to have lost a chance to win due to dangerous racing during the race.

12. The driver has consecutively had bad results.
13. The driver used bad language when discussing the race after finishing.
14. The driver degraded himself or herself during the race.
15. The driver has received a written warning twice.
16. The driver interfered with the fair and safe operation of the race.

#### Article 25 (Written Warning and Caution)

The organizer may give a written warning or caution to drivers who interfere with the fair and safe operation of the race, although the act is not severe enough to have them receive a ban from participating in races.

#### Article 26 (Report of Facts)

In the following cases, drivers or judges must report to a racing operator immediately after noting the following:

1. The driver conspired over or signed an unfair agreement on the races.
2. The driver received, requested, or promised assets or property interests to affect the fairness of the races.
3. The driver inflicted or tried to inflict damage on drivers to affect the fairness of the races.
4. The driver affected or tried to affect the fairness of the races.

#### Article 27 (Decision on Sanctions)

- a. If a racing operator or the head of a relevant department needs to take one of the sanctions in Article 22, he or she must send a letter of opinion to the Motorboat Racing Sanction Deliberation Committee.
- b. The Motorboat Racing Sanction Deliberation Committee may ban a person who receives a sanction, according to the regulation in Article 27-a, from participating in races, or postpone payment of the result prizes and fees to the driver, until a decision is made on the sanction.

### Article 28 (Formal Objection)

- a. If a driver who receives a sanction from the Motorboat Racing Sanction Deliberation Committee has an objection to the sanction, only the driver can lodge an objection.
- b. The driver must submit an application for objection to the Chairman of the Motorboat Racing Sanction Deliberation Committee within 30 days of receiving the sanction.

### Article 29 (Objection Processing)

- a. The objection must be processed within 30 days of accepting the application.
- b. If a decision is made on the objection, the driver must be immediately notified of the result.

## Section 7. Motorboat Racing Judging Methods

### Article 30 (Aim of Decision)

A decision on a driver who conducted an action in conflict with the motorboat racing rules must be comprehensively reached by closely examining and fully inquiring into the three factors that are the cause, passage and result.

### Article 31 (Three Factors of a Judge's Decision)

The aim of the three factors specified under Article 3 stems from the following:

1. Cause: How did the action occur? The motivation.
2. Passage: How did the action progress? The process.
3. Result: How did the results from the action affect the racing or other drivers?

### Article 32 (Judge's Decision Standards)

Specific standards for the judge's decision on the motorboat racing rules are provided to judge candidates by H.S.I at the Training Center.

Section 8. Awards for Drivers - see H.S.I. Handbook

Section 9. Admission Fees and Public Order - see H.S.I. Handbook

Section 10. Winner voting and Betting System - see H.S.I. Handbook

## **CHAPTER 3. RACING RULES**

### Section 1. General Regulations

#### Article 33 (Racing Method)

Participating drivers travel counterclockwise around the racing course as illustrated in Annexed Table 5.

#### Article 34 (Definition of Glossaries)

The definition of the glossaries used in the regulations is as follows:

1. "Racing Course" refers to the water used for motorboat racing, which is clearly marked by buoys.
2. "Waiting Area" refers to the water, which is clearly marked by buoys at intervals of over 150 meters, in the direction of the second turn mark from the start line.
3. "Introduction Run" refers to a racing to introduce participating drivers and motorboats to the audience.
4. "Online start race" refers to a race in which all the drivers leave the start line at the same time.
5. "Flying start race" refers to a race in which drivers pass the start line from the waiting course within a specified time.

#### Article 35 (Waiting for Racing)

Participating drivers must be in the waiting room one hour before their race time, except when the judges allow them for a specific reason.



## Article 36 (Exclusion from Racing)

In the following cases, the judges may prohibit the driver from racing:

1. When the driver used banned substances that may temporarily increase or decrease racing competence.
2. When the driver did not get to the waiting room an hour before the race time.
3. When the driver did not follow the racing operator's orders or instructions in the racing place.
4. When the driver cannot participate due to bad physical condition.
5. When it is necessary to secure the fair and safe operation of races.

## Section 2. Introduction Run

### Article 37 (Racing Method)

- a. Participating drivers must be in the waiting room before the scheduled start time, and when the judge introduces them, they must be routinely racing in the racing course in their designated motorboats.
- b. The judge must introduce drivers before starting the race as follows:
  1. The judge must introduce drivers 30 minutes before the race or immediately after the previous one. The introduction run may be carried out one or two times.
  2. Drivers must be racing in a row in the order of the driver number when they are introduced. They must not be racing in parallel with or ahead of other drivers.
  3. Drivers must be racing in normal racing positions and must not make noise or conduct an act that may provoke the audience's suspicion.
- c. The judge must supervise the whole process of introduction run to ensure that drivers are introduced in an appropriate and efficient way.

### Article 38 (Preparation for Racing)

- a. Drivers who finish the introduction run normally must wait in the waiting room.

- b. Drivers must not change the state of their motorboats after finishing the introduction run.
- c. Drivers, who have not finished the introduction run normally, cannot participate in their races.

### Section 3. Start

#### Article 39 (Preparation for Start)

- a. Drivers must get in their motorboats in the order of the race number, according to the judge's instructions on the preparation for starting.
- b. In the case of online start races, drivers must fix their motorboats to the starting machine.
- c. In the case of flying start races, drivers must leave the moorings toward the waiting area.

#### Article 40 (Start Signal)

- a. In the case of online start races, the start signal depends on the judge's flag signaling.
- b. In the case of flying start races, the start signal is marked by a number plate or a time lamp until a minute before the start time, and then after by a start signal clock.

#### Article 41 (Waiting Behavior)

- a. "Waiting behavior" refers to 'waiting and entrance running' from the moment drivers leave the moorings to the moment right before the drivers start racing, in the case of flying start races.
- b. "Waiting running" refers to the running from the moment motorboats leave the moorings to the moment they turn toward the front at the starting line. "Entrance running" refers to the racing from the moment of waiting running to the moment right before the drivers pass the start line.
- c. While waiting running, drivers must run counterclockwise in the waiting area, in the order of the small turn prevention buoy and the second turn mark. They must not run outside the waiting area.

- d. After turning toward the front at the starting line, drivers must run forward for entrance running, except when there is enough space inside, as other drivers attempt to turn again.
- e. When the driver turns around the inner line again, after turning toward the front at the starting line, the driver must start entrance running from the 5<sup>th</sup> or 7<sup>th</sup> course in principle.

#### Article 42 (Effective Start)

- a. The effective start of each race is as follows:
  - 1. Online start races: Drivers must leave the starting line at the same time, as the devices of the starting machine are simultaneously released.
  - 2. Flying start races: Drivers must pass the starting line within 1.5 seconds from the start time, in the state of waiting behavior.
- b. In the case of flying start races, start violations are as follows:
  - 1. Flying: Drivers pass the starting line before the start time.
  - 2. Late: Drivers pass the starting line 1.5 seconds after the start time.
- c. In the case of start violations, drivers may restart, but may only restart twice. Otherwise, the driver will be held responsible. In the case of flying start races, if a flying or a late start occurs again at the second trial, the race will continue excluding the drivers who violated the starting rules. The betting tickets for the driver excluded will be returned to the ticket purchasers.
- d. The driver who caused a restart due to a flying or a late start is banned from participating in races for a certain period of time, according to the regulations in Article 24.

#### Article 43 (Announcement of Race Suspension/Disqualification)

If a race is suspended or a driver is disqualified for one of the reasons specified in Article 52 (Ineffective Race), the judge must immediately notify the purchasers of betting tickets of the reason.

#### Article 44 (Confirmation of Finishing/Order)

- a. Finishing is confirmed in the order that the tip of the motorboat crosses the finish line.
- b. Drivers must get to the finish line within 30 seconds of the first driver finishing.
- c. The finishing order is confirmed by the judge, but it may be changed if there is a change in the race, as specified in the regulations of Article 43.
- d. The finishing order, which was confirmed according to the regulations of Article 44-a and 44-b, is final in determining the payment for the people who bet on the winner in the betting of the race. It cannot be changed for any reason later.

#### Article 45 (Detailed Regulations)

The organizer will decide on detailed regulations on the judgment standards of the racing rules.

### Section 4. Navigation

#### Article 46 (Ban on Touching)

A motorboat must not put a race in danger by touching or closely approaching the other motorboats, except when it is obstructed by another motorboat or when there are valid reasons.

#### Article 47 (Collision Avoidance)

- a. If two motorboats approach each other, they must avoid the danger of collision by racing as follows:
  1. If they are facing each other, each one must turn in a starboard direction.
  2. If they cross, the motorboat that sees the other one to the starboard must not race across its front.

- b. If the motorboat has to change course due to an obstacle, it must send a signal to the other motorboats, which then must try not to interfere with the racing of the motorboat that has sent the signal.

#### Article 48 (Changing Direction)

If more than two motorboats are racing closely in parallel, they must not interfere with the racing of each other by turning to the side of the other motorboat, except when there is an obstacle or when there are valid reasons.

#### Article 49 (Turn Mark Rotation)

- a. Motorboats must turn counterclockwise around the turn mark.
- b. In the case of Article 49-a., a motorboat must neither damage nor sink the turn mark, except when it is obstructed by another motorboat or when there are valid reasons.
- c. If more than two motorboats simultaneously turn around the turn mark, the motorboat on the outside must give enough space to the motorboat on the inside.

#### Article 50 (Passing)

When a motorboat passes another motorboat, it must run to the port side, except when there is plenty of space.

#### Article 51 (Others)

- a. Drivers must not race using wind, waves, flows, or stirring water with hands, except when the motorboat is broken or there are valid reasons.
- b. Drivers must not interfere with the running and operation of rescue boats.
- c. If there is a damaged or overturned motorboat, or a driver falls into the water, drivers must race maintaining a safe distance.
- d. Drivers, who have been disqualified or cannot race, must quickly leave the course so that the other motorboats are not interrupted.

## Section 5. Void Race and Disqualification of Racing

### Article 52 (Ineffective Race)

The judge may rule the race as void in the following cases, and postpone or suspend the race:

1. No drivers finished the race.
2. The race could not be completed normally due to natural disaster or blackout.
3. It is impossible to hold a normal race, due to the interruptions of people or animals.
4. The race is severely interrupted by the spectators, including stone throwing.
5. The turnaround announcer did not notify drivers of the turnaround or notified incorrectly during the race.
6. The race was not held in a fair, safe way, due to reasons for which drivers are not held accountable.

### Article 53 (Disqualification for Racing)

The judge must prohibit the driver from racing in the following cases.

1. When the driver violated the regulations in Articles 18, 19, 51, 52-b., or 53.
2. When the driver cannot participate in a normal race, because a driver fell into the water or was hurt while racing in the waiting area or at the start time, or because the motorboat was overturned, sunk, burnt, or damaged.
3. When the speed of the motorboat was considerably reduced, due to the imbalance of the motorboat or floating materials before or at the start time.

### Article 54 (Disqualification)

In the following cases, the judge must give a caution or warning, depending on the seriousness of the violation:

1. When the driver violated the regulations in Articles 20, 47, 60, or 65.
2. When the driver did not race at full throttle to win the race.
3. When the motorboat was overturned or a driver fell into the water while racing.

#### Article 55 (Investigation into Accidents)

In the following cases, the judge must immediately investigate the reasons and report the results to the president of the Racing Operation Council.

1. The motorboat did not start.
2. The motorboat did not finish.
3. The speed of the motorboat was significantly slow.
4. There were other accidents.

## **(APPENDIX 2)**

### **OPERATION RULES OF SANCTION DELIBERATION COMMITTEE**

#### **CHAPTER 1. GENERAL PROVISIONS**

##### Article 1 (Purpose)

Pursuant to Article 21 of the U.I.M. Hydro Sprint Enforcement Regulations, these regulations are intended to provide specific matters, related to the organization and operation of the Motorboat Racing Sanction Deliberation Committee (hereinafter referred to as the «committee») to secure fairness in motorboat racing.

##### Article 2 (Applicable Scope)

- a. The regulations apply to motorboat drivers.

- b. Unless otherwise specified in the Motorboat Racing Act and miscellaneous regulations, the regulations apply to the organization and operation of the committee.

## Chapter 2. Motorboat Racing Sanction Deliberation Committee

### Article 3 (Establishment and Composition)

- a. The Motorboat Racing Sanction Deliberation Committee is composed of a chairman and 6 to 14 members, who are selected by the organizer
- b. The Director of the Racing Operation Council becomes the Chairman of the committee, and other members are appointed by the organizer, whenever a meeting of the committee is convened, as specified in Article 3-a.
- c. When the Director cannot perform his duties for unavoidable reasons, one of the members appointed by the organizer performs in his behalf.
- d. The manager in charge of the committee tasks becomes the Secretary who deals with the general affairs of the committee.
- e. The members of the committee must not reveal any secrets that are obtained during meetings of the committee.
- f. Despite the regulations in Article 3-a and 3-b, the chairman may appoint three more external members from sports, academic, and law societies(hereinafter referred to as «external members»). The external members may be paid.

### Article 4 (Convention)

The Chairman may convene a meeting when he thinks it is necessary or over half of the members request that a meeting be held.



### Article 5 (Decision-making)

- a. The committee may decide on matters, when over half of the members participate in the meeting and it gets approval from over two thirds of the participants. The Chairman also has a right to vote.
- b. The decisions made by the committee are put into action after getting approval from the President.

### Article 6 (Agenda)

The agenda of the committee is as follows:

1. Matters related to the cancellation of registration in Article 16-b of the Hydro Sprint Management Regulations (see H.S.I. handbook)
2. Matters related to the suspension of participating in races in Article 21 of the Hydro Sprint Management Regulations (see H.S.I. handbook)
3. Matters in which a motorboat racing operator or a relevant director has asked for a sanction.
4. Matters related to the sanctions in Article 22-1 of the U.I.M. Hydro Sprint Enforcement Regulations.
5. Matters related to applications for objections in Article 28 of the U.I.M. Hydro Sprint Enforcement Regulations.
6. Other matters the committee considers necessary to discuss.

### Article 7 (Participation of the Motorboat Driver Subjected to a Sanction)

- a. If the committee is to apply a sanction to a driver (including cancellation of registration in Article 6-1, the same applies hereafter), it must let the driver participate in the meeting and be given the chance to vindicate himself/herself, unless:
  1. the driver does not vindicate himself/herself within a certain period for some reason, including failure by the committee to notify him/her to participate in the meeting.
  2. the judge has deliberated and decided on a sanction.

3. the driver is in prison for a violation of the Motorboat Racing Act.
  4. the driver receives a sanction, pursuant to the sanction appreciation standards.
- b. If necessary, the Chairman may let relevant people participate in the meeting to give a statement.

### Chapter 3. Sanctions

#### Article 8 (Application for Sanction and the Procedure Involved)

- a. If a motorboat racing operator or a relevant director considers it is necessary to impose a sanction on a driver, according to the provisions in Article 6, he must request the Secretary of the committee to give a sanction and submit factual data.
- b. The Secretary, who is notified of the reason for a sanction, according to the provision in Article 8-a, must check the matter and place it on the agenda of the committee, unless there are exceptional reasons.
- c. If there is an application for an objection, according to the provisions in Article 28 of the U.I.M. Hydro Sprint Enforcement Regulations, the Secretary must directly bring the matter up for discussion, despite the provision in Article 8-b.
- d. If the Secretary takes up the matter for discussion, according to the provisions in Article 16-b and 16-c, he must notify the motorboat racing operator or the relevant director who requested the sanction of the result, according to the provision in Article 8-a.
- e. The motorboat racing operator or the relevant director may ask the driver to submit a written apology over the incident. In that case, he or she must submit the relevant documents to the Secretary. The Secretary must record and maintain a list of the people who have submitted written apologies, using Annex Form 1.
- f. The Secretary must ask the committee to impose a sanction on a person who has submitted a written apology more than three times a year, according to the provision in Article 8-e.

- g. If the Secretary does not have enough evidence or data to explain the reason for a sanction, when he or she takes up the matter for discussion, pursuant to the provisions in Article 8-b, 8-c, and 8-f, the Secretary may ask the person who requested the sanction to complement the relevant evidence or data needed to prove the reason.

#### Article 9 (Processing of a Sanction Procedure)

- a. As for the matter that is to be taken up for discussion or is being discussed by the committee, a sanction procedure must be put in motion, regardless of whether it is being examined by an investigation agency, or waiting for a legal hearing. However, the sanction procedure may be postponed if it is necessary to process the matter after referring to the result, to make a fair judgment.
- b. When a sanction needs to be discussed for a suspect about more than two matters, it must be subjected to a joint discussion.

#### Article 10 (Decision on a Sanction)

- a. The committee must decide on a sanction within 30 days of accepting the application for sanction deliberation.
- b. If the processing of the sanction procedure is suspended, according to the provision in Article 9-a, after a sanction is requested, the suspended period is not included in the decision-making period in Article 10-a.
- c. A sanction approval form must be signed by the participants, and a judgment on the factual data for the sanction and relevant provisions must be specified.
- d. The committee must notify the driver, who is to receive the sanction, of the sanction in Annex Form 2.
- e. If a driver is banned from participating in one race, pursuant to sanction appreciation standards, the committee may make a decision in written form.

### Article 11 (Sanction Appreciation and Its Standards)

- a. The committee may decide on a sanction, considering the driver's previous violations of laws and regulations, intentionality, racing record, usual behavior, racing attitude, attacks, and possibility of improvement.
- b. The President may provide separate appreciation standards to ensure the fairness and consistency of sanctions.

### Article 12 (Added Sanction)

The committee may apply an added sanction to a driver who commits the same wrongdoing within a year of receiving a sanction.

### Article 13 (Reduced Sanction)

- a. The committee may reduce a sanction against a driver who meets the following conditions:
  1. The sanction may be reduced to a suspension of participating in races if a driver, who applies to the provisions in Articles 16-b-1, 16-b-6, and 16-b-7 of the Hydro Sprint Management Regulations (see H.S.I. Handbook), is considered to be regretting his/her wrongdoing.
  2. The sanction may be reduced to a suspension of participating in races if a driver, who applies to the provisions in Article 16-b-4 of the Motorboat Racing Management Regulations (see H.S.I. Handbook), is considered to be trying to improve his/her record.
  3. The sanction may be reduced to a written warning if a driver, who applies to any of the sections under Article 30 of the Hydro Sprint Management Regulations (see H.S.I. Handbook), is considered to be regretting his/her wrongdoing.
- b. The sanction may be reduced to a suspension of participating in races if a driver, who applies to Article 16-b-5 of the Hydro Sprint Management Regulations (see H.S.I. Handbook), is considered to be able to recover his/her racing capacity.

## Chapter 4. Lodging an Appeal

### Article 14 (Lodging an Appeal)

- a. If a person, who received a sanction from the committee, meets any of the following conditions, he or she may lodge an appeal:
  1. The person can prove that the reason for the sanction was beyond his/her control.
  2. There is concrete evidence proving that the original sanction needs to be reduced to a minor one.
  3. The sanction is considered too unfair or harsh.
- b. A person, who wants to lodge an appeal, must submit the application using Annex Form 3 to the Chairman of the committee, within 30 days of receiving the sanction.
- c. If a person who received a sanction lodges an appeal, the Chairman must review it, and if it is reasonable, the Chairman must promptly request the committee to deliberate on the case again.
- d. If the President recognizes that the decision of the committee has a severe, concrete fault or is unfair, he or she may request that they deliberate on the case again. If the committee decides to apply the same sanction, the sanction is confirmed.

### Article 15 (Re-deliberation)

- a. When the committee receives an application for appeal, it must deliberate on the appeal again within 30 days unless there are special reasons.
- b. After deliberating on the case again, the committee cannot apply a harsher sanction than the original one, unless reasons for another sanction occur.
- c. The sanction after re-deliberation is retroactive to the original sanction date.
- d. If the committee decides to reduce or cancel the original sanction after re- deliberation, sanctions against other people, who are involved in the same case, may be reduced or cancelled.

- e. If the committee dismisses the request for re-deliberation or changes the decision on the sanction considering it to be reasonable, it must notify the person of the result.

#### Article 16 (Exclusion and Avoidance)

- a. If the Chairman or members of the committee have personal interests in the case, which is being discussed, they must not participate in the deliberation.
- b. If a person who is to receive a sanction has some reasons to worry that the Chairman or members of the committee may make an unfair decision, he or she may explain to them in writing and request that those individuals not be part of the deliberation process.
- c. If there is an application requesting that some individuals should be excluded from the deliberation process as specified in Article 16-b, the committee must discuss it and decide on whether the person's concerns are justified. In this case, the Chairman or members of the committee, who are the object of the request, cannot participate in the decision-making process.
- d. If the Chairman or members of the committee cannot perform their duties, pursuant to the provisions in Article 16-a or 16-c, they are not counted on the register roll.

#### Article 17 (Effects of the Original Sanction)

The original sanction is effective until a decision is made after deliberating on the case again, which is limited to one time. However, an additional deliberation may be conducted if the case applies to Article 14-a-2 or 14-d.

#### Article 18 (Decision on Repairs)

If a person involved in the case personally submits an application for cancellation of the driver's registration, repairs must be postponed until a decision is made on the case, and must comply with the result of the discussion.

## ANNEXED TABLES

(Table 1)

### The Members of the Racing Operation Council

Members	Duties in charge
President	<ol style="list-style-type: none"> <li>1. Generalizing race operation</li> <li>2. Controlling members of the Committee</li> </ol>
Vice-president	<ol style="list-style-type: none"> <li>1. Supporting President in running and operating races</li> <li>2. Acting as a substitute when president's absence</li> <li>3. Serving concurrently as a member of the Committee</li> </ol>
Facility Managing Director	<ol style="list-style-type: none"> <li>1. Managing and repairing all facilities</li> </ol>
Judging Director	<ol style="list-style-type: none"> <li>1. Deciphering and confirming start/finish, drivers' qualification</li> <li>2. Announcing results of «1»</li> <li>3. Operating and managing judging facilities</li> <li>4. Judging Director may hold deputy judges in order to support its duties</li> </ol> <p>- Signal Judge, Central Judge, First Corner Judge, Second Corner Judge, Inspection &amp; Start Judge, Finish Judge, Time Checker, Recorder</p>
Fairness Controllers	<ol style="list-style-type: none"> <li>1. Preserving discipline around the water stadium</li> <li>2. Supervising visitors</li> <li>3. Treating emergency such as a riot, fires, etc.</li> <li>4. Scrutinizing fairness on races</li> <li>5. Operating doping tests</li> <li>6. Taking sanction to drivers</li> </ol>
Racing Operator	<ol style="list-style-type: none"> <li>1. Composing races and introducing the races</li> <li>2. Executing an aptitude test for participating drivers</li> <li>3. Managing and operating other facilities related</li> </ol>
Ticket Sales Managing Director	<ol style="list-style-type: none"> <li>1. Issuing and selling betting tickets</li> <li>2. Calculating and granting dividends</li> <li>3. Announcing the two above</li> <li>4. Managing and operating Electronic Ticket Sales system</li> <li>5. Managing civil appeals</li> </ol>
Broadcasting Director	<ol style="list-style-type: none"> <li>1. Broadcasting races</li> </ol>
Betting Shop Managing Director	<ol style="list-style-type: none"> <li>1. Managing betting shops</li> </ol>
Driver & Motorboat managing Director	<ol style="list-style-type: none"> <li>1. Managing and controlling drivers</li> <li>2. Maintaining racing boats and other boats</li> <li>3. Managing fuels</li> </ol>
Administration Manager	<ol style="list-style-type: none"> <li>1. Executing general affairs, accounts, etc</li> <li>2. Managing human resources and environmental circumstance</li> </ol>

(Table 2)

## Medical Criteria for Participating Drivers

A doctor judges qualification of participants to a race according to the following criteria. Although a driver who isn't fit to the criteria, he/she may participate in a race as long as the driver is admitted to execute his/her racing ability.

Examinations	Criteria
Surgical Examination	<ol style="list-style-type: none"> <li>1. No external wound causing other serious diseases</li> <li>2. No aftereffect from past surgical operations</li> <li>3. No bone damage or fracture, articular damage, causing disability and other diseases.</li> </ol>
Internal Examination	No disease in internal organs
Ophthalmology Examination	No ophthalmologic disease causing disability
A nose, ear, and throat Examination	No nose, ear, and throat disease causing disability
Others	<ol style="list-style-type: none"> <li>1. No infectious disease</li> <li>2. No chronic disease</li> <li>3. No high temperature and acute disease</li> <li>4. No Other diseases causing disability on a race</li> </ol>



(Table 3)

## The Standards of Boats and Motors

Class	Boats		Motors	
Types and Standards	Type	Hydroplane boat	Type	Outboard motor (The aquatic propeller, which can be attached to the transom of the boat by a person, must be a suitable match for the internal-combustion engine.)
	Length	250~350cm	Engine type	2 cycles, 2 cylinders
	Width	122~150cm	Propeller type	Rotary propeller
	Weight	65~80kg	Cylinder capacity	350~500cc
	Essential equipment	1. Steering wheel and steering system 2. Cowling 3. Pin	Essential equipment	1. Automatic closing throttle 2. Ignition time manual controller (Timer device)
	Res- trictions	-	Res- trictions	1. There must be no supercharger or its equivalent. 2. The lower unit must not be a tractor type. 3. There must be no equipment used that promotes engine combustion, including an oxygen tank.

## Boat Specifications

Applicant	Name			Address			
Boat name	As accepted by H.S.I. Ltd						
Kind	Hydroplane Boat						
Manufacturer	Name			Address			Prod. Date
Total length	290cm		Max. Width	132cm		Max. Depth (Center)	32cm
Weight	76kg			Transom height	28Cm		
Coating characteristics	Urethane sealing and water-proof coating						
Main materials	(1) Shell 2) Frame (3) Deck						
Fixing method				Bottom type	Stair type		
Seat size	Length: 139Cm Width (front): 55Cm (Back): 35Cm			Pin		Number ( ) None	
Others							

## (Tips)

1. Digits after the decimal point must be omitted, when you fill in total length, maximum width, maximum depth (center), weight, and transom height.
2. You must fill in the colors of the bottom, sides, and deck for the coating characteristics.
3. You must fill in wood, light alloy, special steel, etc., for the main materials.
4. You must fill in the fixing materials, such as nails and glue, for the fixing method.
5. You must fill in stairs, flat, round, or V for the bottom type.
6. You must fill in special remarks about the boat in the space for others, if there are any.

(Table 4)

Colors of Racing Uniforms and Motorboats in Their Numbers

Number	1	2	3	4	5	6	7	8	9	10
Color	White	Black	Red	Blue	Orange	Green	Pink	White red	White blue	White black

(Table 5)

### **Racing Course**

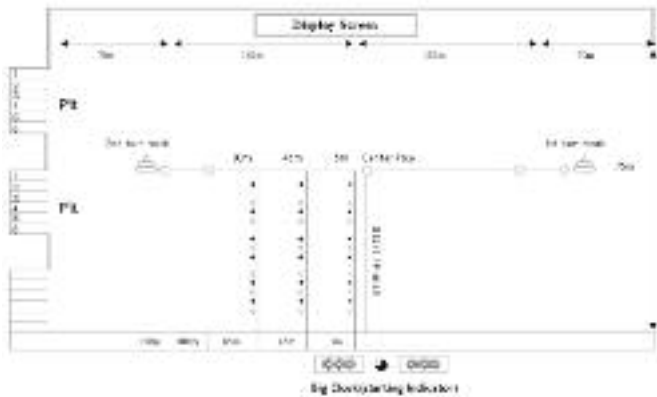

(Annex Form 1)

A List of the People Who Have Submitted a Written Apology

Serial No.	Date	Personal information			Reason(s)	Recorded by	Check
		Div.	Position	Name			

## (Annex Form 2)

## Sanction Notice

Registration No.	Name
Sanction	
Relevant Law(s)	
Reason(s)	
Lodging an Appeal	If you object to the sanction, you may lodge an appeal within 30 days of receiving the sanction, pursuant to Article 14 of the operation rules of the Motorboat Racing Sanction Deliberation Committee.
<p data-bbox="184 589 428 613">We notify you of a sanction.</p> <p data-bbox="184 711 306 735">20.....</p> <p data-bbox="322 1016 664 1075" style="text-align: center;">The Chairman of the Motorboat Racing Sanction Deliberation Committee</p>	

## (Annex Form 3)

## Application for an Appeal

Address:

Name:

Date of Birth:

The person stated above received a sanction from the Motorboat Racing Sanction Deliberation Committee on yyyy/mm/dd and lodges an appeal for the reason(s) specified in the annexed form, pursuant to Article 14 of the operation rules of the committee.

20 . . . .

Applicant

Signature

Attached documents: 1. A copy of the driver registration  
2. A copy of the notice of a sanction  
3. A letter of the reasons for the appeal

The Chairman of the Motorboat Racing  
Sanction Deliberation Committee



### Acknowledgment and Agreement

I, as a member of [National Authority] and/or a participant in a [National Authority or U.I.M.] authorized or recognized event, hereby acknowledge and agree as follows:

1. I have received and had an opportunity to review the [U.I.M.] Anti-Doping Rules.
2. I consent and agree to comply with and be bound by all of the provisions of the [U.I.M.] Anti-Doping Rules, including but not limited to, all amendments to the Anti-Doping Rules and all International Standards incorporated in the Anti-Doping Rules.
3. I acknowledge and agree that National Authorities and the U.I.M. have jurisdiction to impose sanctions as provided in the U.I.M. Anti-Doping Rules.
4. I also acknowledge and agree that any dispute arising out of a decision made pursuant to the U.I.M. Anti-Doping Rules, after exhaustion of the process expressly provided for in the U.I.M. Anti-Doping Rules, may be appealed finally as provided in Article 13 of the U.I.M. Anti-Doping Rules to an appellate body for final and binding arbitration, which in the case of International-Level Drivers is the Court of Arbitration for Sport.
5. I acknowledge and agree that the decisions of the arbitral appellate body referenced above shall be final and enforceable, and that I will not bring any claim, arbitration, lawsuit or litigation in any other court or tribunal.
6. I have read and understand this Acknowledgement and Agreement.

---

Date

---

Print Name (Last Name, First Name)

---

Date of Birth

---

(Day/Month/Year)

---

Signature (or, if a minor, signature of legal guardian)

## A

Absence of race number	206.03
Advance-programme	202
Aerial (boats with aerial propeller)	590
Age limit	203.04
Aid (first aid station)	205.08.02
Altering course	312.12
APBA recognised series	106.01
Appeal (court)	405.01
Appeals (protests and)	403/405
Approaches to the starting line	306.08
Arbitration	409
Authority (change of National)	120.02
Awarding of prizes	322

## B

Ballast	503.12
Base	300-604
Before the start	306.06
Boat starting before time	306.09
Boats (inflatable)	560
Boats (equipment)	503
Boats (fouling competing boats)	314
Boucquey Trophy	803
Buoy and course officers	201.07
Buyse Trophy	801



## C

Calculation of speed	605
Calendar	101
Cancellation of licence	120
Cancelled (race)	308
Cards (yellow)	406.03
Certificate (record)	615.08
Certificate (measurement)	501
Certificates (performance)	614
Championship (world)	107
Championships (continental)	108
Championships (general rules)	106
Change of date	101.04
Change of National Authority	120.02
Circuit	302
Circuit races (rules for)	300
Circulation of the result (record)	615.07
Classes (international series and classes)	500
Classes, sports outboards	540
Classes racing inboards	510-515
Classes eligible for records	601
Classes racing outboards	520
Classes (monohull, outboards)	550
Classes Sport outboard	530
Classes Osy 400	525
Classes Pneumatic	565
Classes Diesel	570
Classes Turbo Sets	580

Classes Aerial Propellers	590
Classes Electric Powered Boats	595
Classes Inflatable	560
Clock	306
Cockpit (reinforced)	509
Clothing protection	205.11
Commissioner (U.I.M.)	102
Committee (powers of the race)	201.01
Committee (organising, race)	201.01
Cost of measurement	501.01
Course (marks of the)	303
Cups (international)	800

## D

Date (change of)	101.04
Deadline dates	101.03
Dead engine start	307
Dead-Heat	319
Deformable pickle-forks	503.02
Deputy Officer of the Day	201.04
Discs	306.02
Disqualification	406.04
Distinctive marks	206
Drag racing	112
Doping test	205.02.02
Duties of the timekeepers	201.09
Duties of the Technical officers	201.07
Duties of the race Officials	201.06
Duty of the Deputy officer of the day	201.04

## E

Electric powered boats	595
Endurance races	902
Entries	203
Entry level racing classes	500.04
Environmental care	704
Equipment of boats	503
Event sanction	101.01
Exclusion	406.07

## F

Fee (entry fee)	203.03
Finishing line	318
Finishing a race	317
First aid station	205.08.02
Flag signals	304.02
Fouling marks	313
Formula Future rules	500.10
Fuel	508-514-519-524-529-534-544-554-564-569-574-584-594

## G

Gun	306.03
-----	--------

## H

Heats (races in several)	318.01
Helmet	205.07
Homologation of records	615
Homologation of engines	505

Homologation sheets	505.11-505.12-505.13
Hulls (inspection of)	321-607
Hydro Sprint racing rules	905

## I

Immersion Test	205.05
Inboard racing displacement class	904
Inspection of engines & hulls	321-502-607
Insurance	205.09
Interested parties	402.02
International races recognised by the U.I.M.	103-104
International series and classes	500
International cups	800
International officers	201.02
Interpretation of the rules	200.02

## J

John Ward Trophy	802
Jet Sprint Rules	901
Jurisdiction	400
Jury	201.01-402
John Hill Trophy	805

## L

Licences	120
Life jacket	205.06-509.04
Lifting of race boats	205.12
Log book	501.11
Low emission engines	541.02-542.12-566.01

## M

Margin required (records)	606
Marks of the course (definition)	303
Marks of nationality	206
Marks (rounding)	312.11
Match race	307.05
Measurement certificate	501
Medical examination	205.01, 02, 03, 04
Medical Officer	201.04.01
Minimum age	203.04
Modifications allowed	528.10-533.10-543.10-553.10 562.10-563.10-568.12-528.10-568.10
Motor shut off switch	509.12

## N

National Authority (change of)	120.02
Nationality of the drivers	203.05, 206.01
Noise reduction	504
Non approved races	104
Number and value of the prizes	322
Number (race)	206.02

## O

Obstacle (definition)	300.01
Officer of the Day	201.03
Organisation of records	600
Organisation of races	200
Organising committee	201

Overlap, overtaking 312.02-08

## P

Passing marks	312.11
Penalties	406
Performance certificates	614
Piston motors	503.07
Pickle-forks	509.02
Posting of the results	320
Postponed (race)	309
Prizes (number and value)	322
Production changes (engines)	505.14
Programme (race)	204
Protection (technical)	205.10
Protests	403
Protests (and appeals)	405
Pseudonym	120.07
Publicity	203.051

## R

Racing instructions	204
Race number	206.02
Race (stopping of a)	311
Race cancelled	308
Race postponed	309
Race shortened	310
Race (finishing a)	317
Races (rules for circuit)	300
Races recognised by the U.I.M.	103

Races in several heats	318.01
Racing licences (rules)	120
Records	600
Record certificate	615.08
Record (circulation of the result of a)	615.07
Report of the Commissioner	102.04
Reports	323
Result (circulation of the result of a record)	605.07
Results (position of the)	320
River Marathon Rules	900
Rotary motors	503.07
Rounding marks	313
Rules of the road	312
Rules (interpretation of the)	200.02

## S

Safety zone	306.05
Safety of the driver	205
Safety boats	205.08
Scoring system	318
Signals from the shore	304
Signals (starting)	304.02
Start (flying)	306
Start (dead engine)	307
Start	305
Starting (boat starting before time)	306.09
Starting in groups	304.03
Starting line (approaches to)	306.08
Stopping of a race	311

Super charging	503.09
Super-licence	120.08
Suspension	406.05

## T

Technical officers	201.07
Technical protection	205.10
Throttle cut-off device (automatic)5	03.03
Timekeepers and timing devices	201.09-301
Timing	301
Titled International events	105
Towing boats	205.08.01
Trophies	800

## U

U.I.M. Commissioner	102
---------------------	-----

## V

Value and number of the prizes	322
--------------------------------	-----

## W

Water registration	106.02
Windscreen	503.02
World championship	107



## **U.I.M. FORMULA 1 WORLD CHAMPIONSHIP**

1. ORGANISATION
2. RACE FORMAT
3. START
4. STOPPED RACE
5. INTERRUPTED RACE
6. RACE COURSE
7. CLASSIFICATION
8. EQUIPMENT
9. FUEL
10. SUPERLICENCES
11. YELLOW CARDS
12. PROCEDURE FOR PROTESTS AND APPEAL
13. SAFETY
14. GENERAL

### **INTERPRETATION OF THE RULES - 200.02**

In all cases unforeseen by the international rules, the National Authority is to adjudicate, bearing in mind the spirit of the rules.

In the case of conflicting rules, these rules concerning the Championship as published in the blue pages of the Circuit Rules Handbook, shall prevail.

#### **1. ORGANISATION**

- 1.1. The rights of organisation of Formula 1 races and championships are owned and ruled by the U.I.M. which has granted the management of the competition to the U.I.M. Council.

The Council may update these rules whenever necessary on request of the F1 Daily Management Committee.

- 1.2. The Formula 1 daily Management Committee is responsible for the championship daily management. This committee is composed of the Promoter (1 vote), the Formula 1 Committee Chairman (casting vote), the team owners representative (1 vote), and the drivers representative (1 vote only on safety issues).

The Formula 1 World Championship is governed solely by the U.I.M. international rules for circuit racing, as published in the white and blue pages of the Circuit Rules Handbook.

- 1.3. The Formula 1 U.I.M. commissioner must check new venues in due time before an event can be sanctioned, as well as the Formula 1 U.I.M. commissioner must be appointed for each race.
- 1.4. A Formula 1 Protest Judge will be nominated for each event and will adjudicate on all protests.

The protest judge must be named in the advance programme.

- 1.5. The Officer of the Day must speak fluent English.

The following officials have to be Club, NA or U.I.M. officials:- O.O.D., deputy O.O.D., safety officer, technical officer/scrutineer, time keeper, pit marshal; pontoon marshal and starter.

- 1.6. It is strictly not permitted to grant club-membership for the duration of the race meeting to interested outside parties.
- 1.7. The U.I.M. flag must be flown from a prominent position at each event.

## **2. RACE FORMAT**

- 2.1. ***Each Formula 1 meeting counting towards the drivers World Championship will take place over a period of two or three days in accordance with the full U.I.M. Circuit Rules for***

***racing, classification, protests and appeals and the specific rules listed below.***

<b><i>Day 1</i></b>	<b><i>12.00 - 12.30 hrs</i></b>	<b><i>Documentation and registration</i></b>
	<b><i>10.00 - 18.00 hrs</i></b>	<b><i>Technical scrutineering</i></b> <b><i>Boats and all racing equipment (including racing gear of the driver) must be in the pits 24 hours before starting the technical scrutineering (fine if not present)</i></b>
<b><i>Day 2</i></b>	<b><i>09.00 hrs</i></b>	<b><i>1<sup>st</sup> Driver's briefing (compulsory for all drivers and radiomen and team managers of each boat) at the race headquarters (fine if not present at the roll call)</i></b>
	<b><i>10.30-11.30 hrs</i></b>	<b><i>Free practice</i></b>
	<b><i>15.00-16.00 hrs</i></b>	<b><i>Timed trials</i></b>
<b><i>Day 3</i></b>	<b><i>09.00 hrs</i></b>	<b><i>2<sup>nd</sup> Driver's briefing (compulsory for all drivers and radiomen and team managers of each boat) at the race headquarters (fine if not present at the roll call)</i></b>
	<b><i>10.30-11.30 hrs</i></b>	<b><i>Free practice</i></b>

<b>14.45 hrs</b>	<b>F1 Powerboat Parade Lap.</b>
<b>15.00 hrs</b>	<b>Formula 1 Grand Prix Duration not to exceed 45 minutes</b>
<b>16.00 hrs</b>	<b>Prize giving ceremony</b>

---

If there is a change to the racing course layout, there may be extra free practice.

- 2.2. No entry shall be considered official until the boat has passed scrutineering and the documents are checked.

Only one boat per driver is allowed to be entered for any championship meeting. Spare hulls and engines are allowed but may be used only as foreseen in the Formula 1 rules.

***A spare boat is defined as a back-up boat and not to be tested along with another boat to determine the best boat to race. The primary boat entered is the boat to be raced, unless the primary boat becomes damaged and is unable to be raced.***

- 2.3. If force majeure causes one of the two time trial sessions to be cancelled the results of the other session will still stand. In the event that less than 50% of the other session is run, then the grid positions will be established using the current championship positions.

- 2.4. Establishment of start-grid positions from the time trial(s).

2.4.1. All drivers must participate ***in the timed trial.***

2.4.2. ***Q1: All boats may run laps at any time during the first 20 minutes of the hour. At the end of the first 20 minutes, only the fastest 15 boats will remain in the water, the excluded boats will fill the final five grid places.***

**Q2: After a seven-minute break, the times will be reset and the 15 remaining boats will then run in a 15-minute session - again they may complete as many laps as they want at any time during that period. At the end of the 15 minutes, the five slowest boats drop out and fill places 11 to 15 on the grid.**

**Q3: After a further eight-minute break, the times are reset and a final 10-minute session will feature a shootout between the remaining 10 boats to decide pole position and the starting order for the top 10 grid places. Again, these boats may run as many laps as they wish.**

**If a driver is deemed by the officials to have stopped unnecessarily on the circuit or impeded another driver during qualifying, his times may be cancelled**

**No refuelling allowed during timed trial.**

2.4.3. **If the time trials are cancelled the grid positions will be established using the current championship positions.**

2.4.4. **Any change of boat, or internal parts of the engine, after the time trial begins means starting at the end of the grid (only 1 engine to be used for both time trial and race).** Any engine changed after time trial will be sealed by the U.I.M. technical commissioner and will be checked for legality **and the driver will start at the end of the pontoon.**

2.4.5. If more than one boat is relegated to the end of the grid, their position will be terminated by qualification time i.e. : slowest qualification time last on the grid, 2nd slowest 2nd last on the grid etc.

2.5. The official practice schedule will be posted at race control.

Testing outside the race circuit and before or after authorised hours is prohibited during the event.

- 2.6. In case of force majeure, this format may be amended by the O.O.D. and the two commissioners.

If a race is shortened due to force majeure, it is at the discretion of the O.O.D. and the U.I.M. commissioner to alter the time table, and if necessary the course layout accordingly.

If the race is declared to be on rough water, the number of laps should ideally be maintained, but may be reduced if seen fit by the U.I.M. Commissioner. If time permits, the circuit layout can be changed, as agreed by the commissioner and the drivers representative.

## **QUALIFICATION PROCEDURE**

- 2.7. The maximum number will be 26 for the race, unless decided differently by the U.I.M. Commissioner and the Promoter and announced at the first briefing.

If more boats are entered for the race, the series contracted boats will automatically have access to the official practice and the timed trials. All other boats will participate in a 30 minutes pre-qualifying which will take place in the morning of Day 1 one hour before free practice; the fastest boat will be allowed to participate in the official practice and timed trials, bringing the number to a maximum of 26. If necessary, the non-qualified boats must leave the paddock area.

- 2.8. The U.I.M. Commissioner reserves the right to place one non-qualified boat in the final event. National drivers from the country hosting the event or a driver selected by the promoter will be eligible. The wild card driver will be announced at the first drivers' meeting.
- 2.9. Before the race, a briefing must be held to examine the main points of the race. The attendees of the meeting, and the agenda, must be in accordance with the rules of the U.I.M.
- 2.10. The U.I.M. Commissioner must ensure that there is a roll-call of names of drivers, radiomen and each one must respond with his

assigned racing number. If the driver is not present to respond when his name is called, a financial penalty will be imposed.

### 3. START

3.1. The start shall be a dead-engine jetty start as described in rule 307, bearing in mind the following

- To increase the length of the pontoon to come close to 5 metres space per boat. This would leave more space to maintain the lanes.
- To incline the pontoon (or change the location of the first buoy) sufficiently not to have the pontoon straight on the first buoy.

In case these points are not feasible, the alternative will be a rolling start upon decision of the U.I.M. Commissioners. Also the Commissioners will apply stronger penalties for drivers not maintaining their lane.

3.2. Boats should be drawn up with dead engine, stern first to a jetty, floating pontoon, or beach.

Boat which do not line up with the boat next to them within 20 seconds of being requested to do so will be penalised financially.

3.3. The distance between the starting line and the first turning buoy must be at least 300 m considering all safety aspects.

3.4. When the Pontoon Marshal is satisfied that all drivers are ready to start, with engines stopped, he will raise a green flag and the O.O.D. will initiate the start procedure, by instructing the starter to raise the 30 seconds board (min. 80 x 80 cm, figures 60 x 10 cm).

Once the 30 seconds board has been raised those drivers starting their engines or leaving the pontoon before all red lights are switched off, will be penalised one lap. ***This lap may be deducted at the end of the race or a drive through penalty may be imposed.***

30 seconds after this board is raised all red lights will be switched on. Between 5-15 seconds after that, all red lights will be switched off and the race starts.

After a period of time the red light will be shown again.

- 3.5. Late starters: A driver who has failed to start before the red light is shown again, must wait until the whole field has passed the start pontoon before he may join the race through the entrance lane to the course.
- 3.6. The starter may decide, if he judges it necessary, to cancel the start by showing the red flag and recommence the starting procedure.
- 3.7. The start jetty or pontoon must be minimum 75 m long or be equal to 5 metres multiplied by the maximum number of boats permitted to race, (whichever is the greater) and must be at least 1.5m wide.

The alignment of the start pontoons must be such that the pole position has the maximum advantage towards the first turn buoy, compared with the last positions on the starting grid. The plan of the circuit (including the position of the start pontoon) must be sent to the U.I.M. office 60 days in advance of the race date for approval.

- 3.8. Any boat not starting must be returned to shore by the driver's own efforts. Any crew member swimming out to a boat will cause his entry to be disqualified.

Only uniformed crew who are Formula 1 team members with Formula 1 passes designating pit starting pontoon admittance will be allowed on the starting pontoon.

- 3.9. The start procedure may be changed in order to separate the boats into two groups from the start until the first buoy by guiding the drivers through 2 different gates marked with 2 large buoys ahead of the first turn buoy. The daily management committee will decide whether to apply this system and full details on the starting system will be given at the drivers briefing.



- 3.10. An overlap may only be established when two boats are on the same course or approximately on the same course and the overtaking boat has no longer a free choice on which side he shall pass.

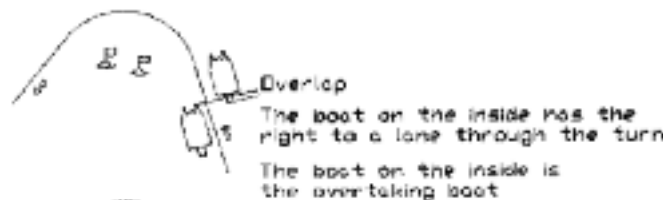
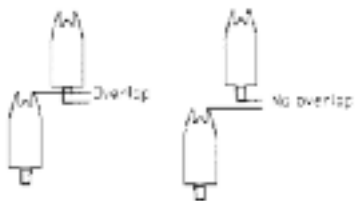

## 4. STOPPED RACE

- 4.1. In the event of the race being stopped, boats must return under their own power to the start pontoon [or other position on the circuit notified by the U.I.M. Commissioner during drivers' briefing]. Alternatively, the yellow flag may be shown and all drivers will continue at slow speed with no overtaking.
- 4.2. Drivers receiving outside assistance at any point during the race (whether the race has been stopped for an incident or not ) will be disqualified.
- 4.3. Boats that have broken down and received outside assistance by being pulled to the infield or off the race course will be towed to the launching pontoon only during a «race stop» condition and if pick-up boats are available.
- 4.4. Repair or maintenance work may only be carried out on boats that have returned to the launch or start pontoons under their own power. Repaired boats may rejoin the race at any time as directed by the pontoon Marshal. Further definition of the repair areas will be given at drivers briefing.
- 4.5. No repairs are allowed on the start pontoon during the line-up and start or re-start procedure.
- 4.6. Drivers may carry-out their own repairs on their boats in accordance with the rules. The driver's two nominated pontoon mechanics and the official crane driver do not count as outside assistance.
- 4.7. In the event of a restart, a boat being repaired must be ready to take its position on the grid as directed by the pontoon Marshal. If the boat is not ready to take its position, it must start at the end of the pontoon.
- 4.8. The re-started race distance will be the original race distance minus the total number of laps completed by the leading boat at the time of the stoppage, minus also 1 lap per re-start.

- 4.9. Starting positions for restarts, or final classification if there is no restart, will be determined by the order at the end of the lap prior to the race being stopped.
- 4.10. The race organiser may at any time determine who was responsible for a race stoppage, even after the race is finished; in which case the guilty driver[s] will be disqualified from that race.
- 4.11. It is mandatory that all boats have remote controlled red and yellow lights in their cockpit. It is the drivers' responsibility to ensure that these lights are functioning and that they are clearly visible to the driver whilst racing.
- 4.12. In case of a race stop, the rescue boats and race control will show the red flag and race control will switch on the red light in the boats.  
  
At this signal all drivers must immediately slow down and return to the starting pontoon, or the previously defined re-start area.
- 4.13. The decision and procedure to have restart from pontoon or from milling area will be announced at the drivers' briefing.

## 5. INTERRUPTED RACE

- 5.1. The position of the boats for the restart will be that of their passing order on the lap before the yellow signal was given. Boats which do not restart in their correct position ***may be given a one lap penalty or a drive through penalty may be imposed.***
- 5.2. When the yellow flag is shown, the leading boat or a designated boat will act as pace boat, and run at slow speed. The yellow flag will be used by race control and the rescue boats to indicate a hazard when displayed stationary, and extreme caution to be exercised by drivers when waved vigorously.
- 5.3. The Organiser may interrupt the race for any reasons of safety or emergency services access, and in which case the rescue

boats and race control will show yellow flags and race control will switch on the yellow lights in the boats.

At this signal all drivers must immediately slow down and not overtake. Any overtaking, 5 seconds after the yellow signal has been given, will be penalised by 1 lap unless instructed by the O.O.D. or U.I.M. Commissioner to change position of the rolling restart.

- 5.4. When the race course is clear, only the yellow flag at race control will be continued to be shown.
- 5.5. All boats maintain their position at slow speed (approx 4000 rpm) until race control **turns off the yellow light**. It is the responsibility of the team managers to ensure that their boat(s) are at the correct position at the restart.
- 5.6. When a rolling start is used, if minimum the first 10 boats are in their correct position, the U.I.M. Commissioner can restart the race using the timing screen or the green flag.
- 5.7. During the yellow signal situation, a boat may leave the race course but must re-join the race behind the boat running in last position.

## 6. RACE COURSE

- 6.1. The length of the straight between any 2 turning buoys is to be a maximum of 850 metres.
- 6.2. There must be a minimum of 2 cranes for launching boats.
- 6.3. The boundaries of the water on which practice and racing are allowed to take place must be defined in the advance-programme.
- 6.4. The pit area should be sufficiently large to prevent boats being craned into the water over other boats.
- 6.5. Safety rules shall be those of the U.I.M. applicable on the date of the race unless specified otherwise by these rules.

- 6.6. Right hand turns can be inserted on the race course.

In order to avoid any confusion, left hand turns will be marked by orange buoys and right hand turns by yellow buoys.

## 7. CLASSIFICATION

- 7.1. The boat placed first will be the one having covered the scheduled distance in the shortest time.
- 7.2. All boats will be classified by taking into account the number of complete laps that they have covered and for those which have completed the same number of laps, the order in which they crossed the finish line.
- 7.3. The number of laps completed during restarts will be taken in account for the classification.
- 7.4. Points will be awarded to the first 10 classified drivers on the condition that they have completed at least 70 % of the number of laps covered by the winner (rounded up or down in a mathematical way e.g.  $18.5 + = 19$  and  $18.49 = 18$ )
- 7.5. Boats that complete 90% or more of the race distance, but do not cross the finishing line after the winner has crossed the finishing line, will be classified after those boats that have done the same number of laps but that also cross the finishing line after the winner.
- 7.6. To be awarded full points, the leading boat must have completed 70 % of the number of laps counting for the race.
- 7.7. If a stopped race cannot be restarted due to «Force Majeure», points will be awarded in accordance with the following scale:
- |   |             |
|---|-------------|
| 70% or more of the total race completed | Full points |
| less than 70 % completed                | Half points |
| less than 35% completed                 | No points   |

7.8. Finishing points scale for each race :

First	20	points
Second	15	points
Third	12	points
Fourth	9	points
Fifth	7	points
Sixth	5	points
Seventh	4	points
Eight	3	points
Ninth	2	points
Tenth	1	point

7.9. The overall classification for the Formula 1 Drivers' World Championship shall be established by the addition of all points obtained by each driver in each of the races counting towards the championship.

The points are personal and are not allocated to the team. Each driver scores his own Championship points. If a driver changes team during the course of the season, he keeps his points.

7.10. In the case of a tie, the number of first places in these races shall be considered, then the second places, etc..

When total points are the same and all listed Tie Breakers have been exhausted, the Driver with the most pole positions will be declared the Winner. This procedure will be carried out to 2nd position on the starting dock and further if needed.

7.11. Immediately after the race:

The winner *may* complete a lap of honour

Top 3 finishers must have priority at the pontoon to be able to reach the podium within 15 minutes.

7.12. Presentation of trophies to first 3 drivers on the official podium. This presentation is only based on a provisional classification, and is subject to confirmation after scrutineering and consideration of any protests or appeals.

- 7.13. At the last race of the series U.I.M. will provide 3 medals (gold, silver, bronze) to be given to the first three in the overall classification of the World Championship.

These medals do not replace the normal prizes (art. 108.01 and 322).

## 8. EQUIPMENT

### HULL

- 8.1. The hull is free for each of the three capacities but must conform to the Formula 1 rules.
- 8.2. Hull, sponsons, and powerhead replacements and other parts are allowed after scrutineering, up until ***the start of the timed trial***, but any changes to be made must be immediately notified to the U.I.M. technical Commissioner for re-scrutineering and sealing and technical inspection of units removed.
- 8.3. Any replacement of boat or sponsons after qualifying time trials will result in all previous times achieved being cancelled, and the replacement boat or sponsons will be considered as a new entry, requiring full scrutineering. If no timed practice opportunity remains, the boat will start from the end of the grid.
- 8.4. Repairs are allowed at any time during the race weekend with the exception that the replacement of hull, sponson, crankcase, or cylinder block, is not permitted after the start of the race. Repairs are not allowed on the race course using outside assistance.
- 8.5. The weight of the boat, including residual fuel and oil, the driver with personal equipment, but excluding loose water is
- |            |                 |
|------------|-----------------|
| 2.0 litres | 486 kilogrammes |
| 2.5 litres | 550 kilogrammes |
| 3.0 litres | 586 kilogrammes |

The first six classified boats will be weighed with scales after time trials and the race. The weighing of the boats cannot be protested. The scales will be available before the meeting commences.

Upon request of the U.I.M. Commissioner, drivers must allow to be weighed separately.

- 8.6. The minimum length (measured along the sponson) is 4m80 for all three capacities
- 8.7. Radios in boats are mandatory and a full radio check of each boat will be part of technical scrutineering in order to guarantee that all radios are working. The radioman must be present at race control whenever his boat is on the course. In order to guarantee clear communication between the Radiomen and the U.I.M. Commissioner, all Radiomen must speak English.

If team manager is unavailable, the assistant team manager must be in the pit area all time for any communication with the U.I.M. Commissioners ; team manager and assistant team manager both of them must speak English.

- 8.8. Each wing mirror must have minimum size of 60 sq. cm and be bolted on 2 points to assure proper mounting.

Within one team, two identical boats must have different colours of mirror bodies as follows:

Odd number: yellow fluorescent colour;

Even number: orange fluorescent colour;

Third boat of the team : black.



## ENGINES

### TECHNICAL RULES TILL END OF 2010

#### ENGINES

1. A grandfather rule applies for all Formula 1 outboards that were homologated and eligible to compete up to and including the 2003 season. These engines are :
2. Mercury 2.5 EFI          Homologation sheet No: F-1/00496
3. Johnson 3.0 EFI          Homologation sheet No: F-1/00497
4. These engines will continue to be eligible for as long as they are competitive; they will be governed by their original homologation sheets supplied when new. These grandfather units will be taken as the performance benchmark for newcomers, with an objective of a nominal 350 hp performance ceiling. Modification of the OEM mapping in the Electronic Control Unit is permitted.
5. The Formula 1 management committee reserves the right to review four stroke or new two stroke engine performance at mid-season in the event that one or the other is too performant within the meaning of these rules. If deemed appropriate, they will modify the diameter of the engine's induction restrictor. A four week grace period will be allowed for modifying and fitting the restrictor plates, from the date of announcement of the change.
6. These technical specification for Formula 1 racing engines permit the engine [ comprising of the power-unit, drive-line, propshaft, mounting system, steering, hydraulic, and electrical controls ], to be installed as an outboard, inboard, or inboard / outboard, in any drive configuration. Lower units converted to single drive-shafts are NOT permitted.
7. Formula 1 boats must be water propeller driven, no airscrews are permitted.

8. Formula 1 engines must have a fixed ratio direct drive. Variable ratio gearboxes, friction clutches, and torque multipliers are not permitted.
9. Atmospheric induction engines with a maximum of 8 cylinders, will be admitted up to 3.0 litres nominal capacity; grouped into the following measured engine capacity ranges :
  - 2.0 litre measured capacity 1950 to 2200cc
  - 2.5 litre measured capacity 2101 to 2600cc
  - 3.0 litre measured capacity 2551 to 3200cc
10. Forced induction engines with a maximum of 6 cylinders will be accepted with an equivalent capacity calculated by multiplying the measured capacity by 1.4. The maximum measured engine capacity admitted will be nominally 2 litres, hence:
  - 2.0 litre measured capacity 1200 to 1575cc equivalent to 2200cc
  - 2.5 litre measured capacity 1501 to 1860cc equivalent to 2600cc
  - 3.0 litre measured capacity 1822 to 2290cc equivalent to 3200cc
11. Power units may be of any internal combustion design, of limited or series production.
12. Rotary motors will be rated in accordance with rule 503.08.
13. Diesel, external combustion, or gas turbine engines are not eligible.
14. 'Green engines' are to be encouraged [with respect to emissions] through incentives determined from time to time by the Formula 1 committee.
15. Engines must be capable of being silenced. If a particular race organiser requests it for local reasons, rule 504 will be applied and engines must not exceed a maximum decibel rating of 98 +6 db(A) when measured as rule 504.03.
16. If silencers are required to conform to the maximum noise rating, it is mandatory to have them available at all races. Compliance is required for scrutineering clearance.

17. To reduce environmental pollution, running-in of engines at the launch jetty or other specified area, will only be permitted by the Technical Commissioner and, if required by the Technical Commissioner, effective mufflers must be used
18. Non-compliance with noise regulations will be financially penalised.
19. New engines will be accepted provided the engine/drive units are submitted for verification, the spirit and letter of the performance target of these rules is respected, and they are freely available to be purchased at a price approved by the F1 Daily Management Committee.
20. To qualify, the manufacturer must present a complete power-unit assembly for verification by the U.I.M. technical officer or delegate nominated by the F1 Daily Management Committee.
21. Applications for homologation of a new engine, which will include a fully completed homologation form with recognition photographs, must be submitted no later than October 15th of the year preceding the first season of use. U.I.M. verification and approval will be completed no later than 6 weeks after receipt of the application.
22. Manufacturer name and colour must be used as homologated.
23. Running production changes will be accepted only once per year for the crankcase / cylinder assemblies, and notification must be received by October 15th of each year. Running production changes for all other components may be submitted for approval at any time. Legality for use will be considered by the Formula 1 committee, taking into account any affect the change will have on performance. If accepted, changes will be effective immediately after approval, and will be conditional that the affected components are freely available at a reasonable price. All interested parties will be notified by U.I.M.
24. In the case of an engine proving to be illegal, penalties will be imposed in accordance with rule 406- Penalties

## POST-RACE SCRUTINEERING

1. The measurements registered on the homologation sheet will be used as a reference for technical verification of the engine's legality. All dimensions given are absolute maxima [ or minima, as the case applies ] and no tolerance is given. The Original Equipment Manufacturer will build engines that are within the dimensions and conform to the homologation. The absolute responsibility will be passed onto the driver, at time of sale, to ensure that the engine maintains its legality irrespective of whatever maintenance or setting-up work is carried-out on it. Technical scrutineering will be carried-out using manufacturer produced gauges handed over at time of homologation to the U.I.M. These gauges will be used on a 'GO', 'NO-GO' basis. If the gauge does not go the dimension is legal.
2. The technical commissioner at each event will decide the degree of dismantling for inspection to be carried-out on the first three classified entries, and his decision will be final.

## 9. FUEL

- 9.1. Official fuels will be supplied by the Promoter / organiser at each race venue.

***As from 2010 onwards, at least 10 % of the fuel composition must be bio-fuel if that type of fuel is available (Bio-ethanol and alkylates).***

It will be of a continuously consistent specification and quality ; conforming to the data sheet and samples issued at the beginning of the season and agreed between the U.I.M., the Promoter and the Engine Manufacturers.

Only this fuel will be used; teams bringing their own fuel to the race venues will be penalised.

- 9.2. Fuel samples taken at random from competitors during the event will be tested at the race venue and may also be analysed afterwards at a laboratory.

Drivers disqualified for fuel infringements will have to pay all laboratory testing and analysis costs.

- 9.3. The only permitted addition to the fuel is lubricating oil for two stroke motors. The use of additives aimed at increasing the power of the motor is prohibited to either the fuel (carburant) or the air intake (comburant).
- 9.4. No chemical starter aids are permitted on the start pontoon.
- 9.5. All participants are subject to thorough inspection at any time. The entire fuel system may be disassembled, removed from the boat and inspected and/or fuel samples taken. The presence of illegal fuel, at any time, on the onboard fuel system will result in immediate disqualification from that part of the race.  
  
The legality of the fuel is to be adjudicated solely by the U.I.M. commissioner, based on all tests and information available to him.
- 9.6. No refuelling will be allowed when the boat is not on its trailer.

## **10. SUPERLICENCES**

- 10.1 A super licence is required for Formula 1 together with the NA international licence. No other membership is required.
- 10.2 A driver who exceeds 50 years of age in the season for which he is applying for a Superlicence, must produce the medical certificate including all detailed examinations which will be submitted to a doctor approved by the U.I.M.
- 10.3. The nationality of a driver is the nationality of the N.A. which issued the international racing licence to the driver. Medical and immersion tests can be done in other countries if the issuing N.A. agrees. The flag is the one of the issuing N.A. of the international licence as above. The request for the U.I.M. Superlicence must come from the N.A. which issues the international racing licence.
- 10.4. Drivers must hold a U.I.M. superlicence before entry will be accepted.

- 10.5. Any new driver must be vetted during practice by the two U.I.M. Commissioners and the Formula 1 drivers representative to the U.I.M.
- 10.6. To obtain a superlicence, a driver must have participated in 6 circuit races using a catamaran type hull (750cc minimum) or a hydrocat (500cc). Definition of a race during a race weekend, even if several heats are taking place, is that the race weekend with all heats or races is counting for one race only. The National Authorities are fully liable for the sports c.v. they submit for their drivers. The full race results of each race must be supplied since the drivers must have done at least 6 races with 70 % of the total distance of each race event.

The superlicence is provisional for the first 10 races and can be withdrawn at any time during the first 10 races by a committee composed by the O.O.D., the Formula 1 Commissioner and the Drivers representative. When a provisional superlicence is withdrawn, re-application can only take place for the next season. The decision on all matters concerning superlicenses is final and cannot be protested or appealed.

- 10.7. The application for a superlicence must be made by the National Authority of the driver concerned and lodged with the U.I.M. 4 weeks before the first event the driver wants to participate in. The superlicence fee of 120 Euro will be doubled for applications received beyond the 4 weeks deadline.

The application must be accompanied by:

- The sports career of the driver, mentioning the results obtained in the qualifying events;
- U.I.M. medical documents, as per appendix to these rules, giving the information required by the U.I.M. rules 205.03 / 205.04 / 205.04.1;
- General Recommendation for F1 superlicense holders concerning physical fitness;

- Cardiovascular training (endurance training) as jogging, cycling, rowing etc. twice a week - minimum 20 minutes without any interruption. Any sports activity which has “stand still” during the activity such as soccer, tennis or any ball sport is not suitable for the endurance training, but recommended as additional training;
- Training to build up muscles for neck and back at least twice a week;
- The immersion certificate (ref 205.05);
- A photograph;
- The fees will be fixed by the Council;
- A current rule book will be given to the driver along with the superlicence.

The National Authorities are responsible for the information given.

- 10.8. Superlicence application will be examined by F1 Daily Management Committee who will decide on its acceptability.
- 10.9. The superlicence will be valid for 1 year (from January 1st or from the date of issue to December 31st).
- 10.10. For renewal of superlicences, the National Authorities must, before the end of December, send the U.I.M. a list of the drivers for whom a renewal for the following year is required.
- 10.11. Each team will appoint one team manager who will be responsible for obtaining a team licence from the U.I.M. for his team, as well as ensuring that the drivers obtain their superlicences from their N.A.'s. He will also be responsible for enrolling his two boat team in the Championship and for all dealings (contractual, financial) with the U.I.M. and IDEA MARKETING.

He will also be responsible for the behaviour of his team members and his name will be mentioned on the U.I.M. Team Licence.

## 11. YELLOW AND RED CARDS

- 11.1. All yellow cards issued will be confirmed on a form which will be posted with the results. The driver has 60 minutes to protest to the Protest Judge. If the protest is not upheld, he can appeal. Protests and appeals must be lodged in accordance with U.I.M. rules.

Yellow cards given in other Formulae Series (F2) will be taken into account on the yellow card listing.

- 11.2. Yellow cards can be given for the following reasons:

- up to two yellow cards at a time for dangerous driving;
- Red card for extremely dangerous driving.

A driver who has a red card or three valid yellow cards will lose the right to take part in the following round of the World Championship (current season or following season), but his boat must participate in the race with a substitute driver. When a penalty of not racing at the next race has been satisfied, the 3 yellow cards or the red card are deleted by the application of that penalty.

- 11.3. All cards will remain valid for the four events of the Championship following the date on which the last card was delivered.

Participating in training, timed trials, and final race will be considered as having completed one event.

Any yellow card will be served the following round of the World Championship. If a red card is issued, the driver will be immediately disqualified from the event he was issued the red card.



- 11.4. An organiser/N.A. who has given one or more yellow cards to a driver must inform U.I.M. by fax or mail within 3 days. U.I.M. will inform the next organisers/N.A.'s. of the World Championship races about the delivery of such yellow cards. When a driver has completed 4 races without yellow cards, his previous yellow card(s) will be deleted from the listing.
- 11.5. Yellow cards issued must be mentioned in the commissioner's report which must be distributed to all members of the relevant U.I.M. Formula commissioners panel.
- 11.6. Penalties, fines and yellow cards will be issued in accordance with the following list:

INFRINGEMENT	FINE (IN EURO).
Boat and racing gear too late in pits	420 €
Registration after specified time	420 €
Not present at drivers meeting roll call	840 €
Not respecting dress code	135 €
<b><i>Missing compulsory functions</i></b>	<b>1000 €</b>
Not respecting exit lane	1 yel or 200 € decision O.O.D./
U.I.M. Comm.	
Not respecting entrance lane	1 yel or 200 € decision O.O.D./ U.I.M. Comm.
Radio man not at timing control	420 €
Not lining up in 20 seconds	340 €
Not in correct position on parade lap	End of the grid
Destroying first buoy	420 €
Destroying second buoy	420 €

<b><i>Destroying first buoy during the race</i></b>	<b><i>1 lap and 420 €</i></b>
<b><i>Destroying second buoy during the race</i></b>	<b><i>disq. and 420 €</i></b>
Overtaking under yellow flag	1 lap
In pit during yellow flag	last position
Not in correct position under yellow flag	1 lap
Dangerous driving	1 or 2 yellow
Extremely dangerous/dirty driving	red card
Driver refusing to be weighed separately	405 €
Not using red/yellow light system in boat	420 €
Taking outside assistance	disq
Responsible for stopping the race	disq
Taking technicians on boat (not applicable to the race winner)	340 €
Noise / silencer violation	510 €
Bringing own fuel to race venue	840 €
Not respecting instructions of U.I.M. Comm / and or Officials	200 €
Not connecting fuel pump lanyard to life jacket	1000 €
Closed valve of airbag system :	1500 €
No closing safety belts during time trials, free practice and the race :	5000 €
Taping the deck plate during <b><i>practice, time trials and</i></b> race	1500 €
Not connecting roll-over switch	1500 €
Top 3 finishers not reaching podium within 15 minutes after end of the race	2000 €

***No testing on the race course 7 days prior to the race for any race team. The only exception for any boat to be on the race course would be the 2 seater, or a boat for TV or promotion publicity, but not times will be taken, nor changing of propellers. 3000 €***

Jumping the gun:

Commissioners shall notify the team of the jumping of the gun infringement within 5 laps from the start of the race and then the driver must go back to the last position immediately

Non respect of rules whilst overlapping : the radio man will be show a yellow card - if his boat is still not out of the way, the red card will be shown and his boat will be disqualified.

The Daily Management Committee may decide to apply a “drive-through” immediate-penalty in cases that carry a 1 lap penalty. ***The driver will exit the race course at the exit lane and reduce speed to safely proceed to the start pontoon. The pontoon marshall will give the signal to safely re-enter the race through the entrance.*** This will be announced in the advance programme and/or the driver’s meeting. The drive-through penalty can only be taken under Green Flag conditions. This will be communicated from the Commissioner to the driver via his radio person and a board flashing the drivers boat number. The driver must complete the drive through penalty within three green flag laps of the announcement. He must leave the course at the pit entrance buoy and enter the race course at least at the back of the field maintaining 4000 r.p.m. during the penalty lap under the green flag. Failing to comply will result in disqualification for the race.

The F1 Daily Management has the right to fine a drivers and crew (money or suspension) for any infringement of the rules or any abusive or unsportsmanlike behaviour.

## **12. PROCEDURE FOR PROTEST AND APPEAL**

- 12.1. A protest can be lodged in accordance with the 400 rules either by the driver or the team manager.

Protests lodged by any driver or his team manager must be handled by the Protest Judge according to the rules.

The protest fee for F1 is 250 Euro.

- 12.2. An appeal must be submitted in writing (fax, mail) to the U.I.M. office for the attention of Secretary General within the specified time limit and signed by the driver or his team manager.
- 12.3. The time limit for appeal submission is 48 hours, and is counted from the moment of the communication of the protest judge's decision to the interested parties.

The 24 hours of the Sunday do not count within the 48 hours to appeal. Address, telephone, e-mail, and fax should be clearly mentioned on the appeal so that the U.I.M. can send any correspondence directly to the driver, with a copy to his N.A.

- 12.4. The driver may agree to forego an Appeal Committee meeting and for the appeal to be handled through telephone and fax, if possible, in order to minimise the costs of the appeal.
- 12.5. The Formula 1 Committee will select an Appeal Committee of 3 persons, who are neutral and independent parties; the chairman will be legally qualified.

The decision must be given within 7 days and in any case before the start of the following race.

## **13. SAFETY**

- 13.1. Following an accident, the driver must undergo a physical examination and be passed fit by the event medical staff before being permitted to continue in that racing event.

Following any accident, damaged boats must be completely rechecked and approved by the U.I.M. Commissioner before being permitted to rejoin the event.

- 13.2. Immersion tests at race venues will be carried-out by Osprey at least once during the season, starting with the first event in the calendar. Drivers may alternatively have a test in UK, by arrangement. Drivers entering the series part way through, will be accepted with their own National Authorities immersion test certificate, which will be valid only up to the time of the next immersion test organised by Osprey.

An example of the certificate and instructions of how to perform an immersion test are available at the U.I.M. Secretariat.

- 13.3. The deformable pickle forks are mandatory according to rule 509.02.
- 13.4. Reinforced cockpits are mandatory according to rule 509.

Cockpits manufactured after January 1, 2010 shall have the aft portion closed off in a fashion to encourage the deflection of a boat colliding from a direction aft of the cockpit. To meet this objective the closed off area (the rear bulkhead) shall slope upward as shown in Figure 1. In addition the closed off area shall be rounded in the top view as shown in Figure 2.

The interior backboard behind the driver shall be provided with an opening 100 mm high and extending the full width of the inside of the cockpit. The vertical elevation of the bottom of the opening shall be at an elevation at the drivers shoulder line.

Additional horizontal bulkheads shall be provided above and below the backboard opening, extending to each side and the closed rear of the cockpit. The lower of these horizontal bulkheads shall be installed at ninety degrees to the driver's spine as shown in Figure 1. Driver's shoulder harness shall be attached to this lower bulkhead at a distance apart of 100 to 150 mm. Where seat belt fasteners penetrate this bulkhead, inserts are to be used as in 509.18.

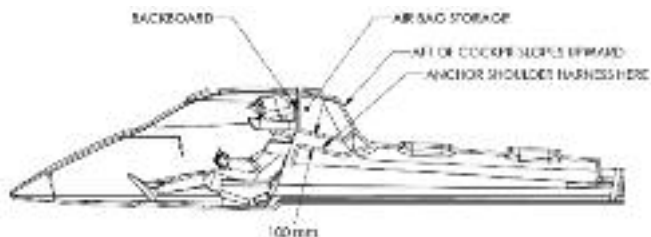

FIGURE 1

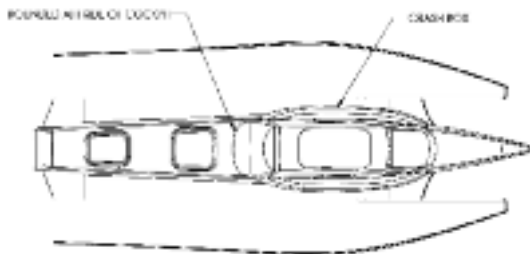

FIGURE 2

Two alternative construction methods shall be permitted for this rear bulkhead:

3. The bulkhead may be molded integrally with the capsule. The layup of this bulkhead shall match that of the capsule as has been registered with U.I.M.
4. The bulkhead may be bolted to the capsule in order to provide access to the space behind the driver. Older boats may also be upgraded in this manner. The layup of this bulkhead shall also match that of the capsule that as has been registered with U.I.M. Bolting of the bulkhead to the

capsule shall be accomplished as shown in Figure 3. A minimum of ten 8mm bolts with SAE Standard flat washers shall be used to fasten the bulkhead to the capsule. The flanges through which the bulkhead is bolted shall not have a honeycomb or foam core. Each of the flanges shall have a minimum thickness of 3 mm. To prevent corrosion of the fasteners, it is recommended that carbon fiber not be included in the layup of the flanges. If carbon fiber is included it is recommended that it be electrically insulated from the fasteners. Blind fasteners may be used.

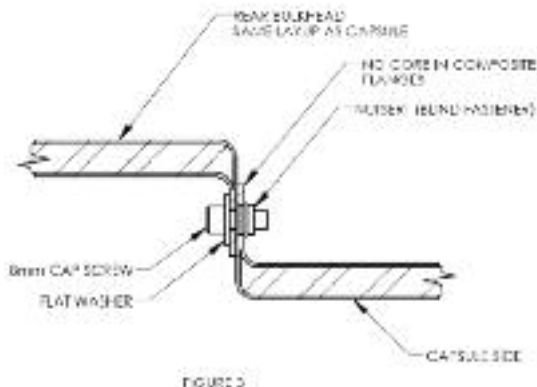

FIGURE 3

5. ***For existing cockpits manufactured before January 1, 2010 a third alternative construction may be used and will be mandatory starting January 1, 2011. Cockpits manufactured after January 1, 2010 may also use this third alternative construction.***

***The third method of construction will consist of an add on crash box located behind the existing back board. The materials and construction of this crash box will***

***conform to the materials and lay-up of the side crash boxes as certified by U.I.M. for the manufacturer of the boat. Existing foam flotation may be removed to accommodate this rear crash box.***

***This rear crash box shall extend to the inner sides of the cockpit and the top under side of the cockpit or the underside of the air bag enclosure. The crash box shall extend down to the deck line or below. Exceptions on the side may be made for fastening. Minimum thickness everywhere on this crash box shall be the same thickness as the side crash box. Shape of the back of the crash box is free as long as the minimum thickness is maintained. This rear crash box must be removable for inspection. The crash box may be fastened from the inside of the cockpit with bolts, or from behind the backboard with minimum 2,5 cm straps anchored to the seat belt mounting bar.***

- 13.5. Life jackets incorporating pants, are mandatory.

Drivers must wear a life jacket so constructed at the shoulders and the legs, that a driver can be easily pulled out of the cockpit.

“Kevlar” type ballistic material in life jackets/ driving suits is not required.

Flotation overalls are a permitted alternative to life jackets, but must incorporate extraction handholds for driver removal from the cockpit.

It is recommended that the colour of the floating overalls is orange.

- 13.6. The homologated delayed operation buoyancy airbag is mandatory.

The maintenance of the airbag system is the responsibility of the team.



13.7. U.I.M. reserves the right to introduce safety rules effective in a reasonable time following notice.

13.8. There will be an official rescue team contracted by the promoter for the entire season.

All local services provided by the organiser will work in conjunction with the official rescue team under the overall control of the O.O.D., his substitute or the medical officer.

13.9. It is not permitted to take technicians on the boats (financial penalty will be applied).

The winner can take his technicians for the victory parade lap only. A rescue boat will follow the winning team at close distance.

13.10. Seats are mandatory for F1 / F2 cockpits and very strongly recommended for all other cockpit classes (for description see 509.08).

13.11. Hans device is recommended for F1 - see 509.08.

13.12. F1 cockpit boats must have U.I.M. registered safety crash boxes installed on both sides of the safety cockpit.

13.13. All craft must have an isolation switch as close to the positive terminal of the battery(ies) as practicable (negative terminal if positive earth system is employed).

The operating handle of the switch must be easily accessible on the deck or other surface of the boat on the port side between 1 to 3 meters forward of the stern.

This switch must be marked with a red flash + and the ON/OFF positions shown.

13.14. Mooring eyes must be placed on the back of each sponson no more than 20 cm in from the outside of the sponson -see drawing

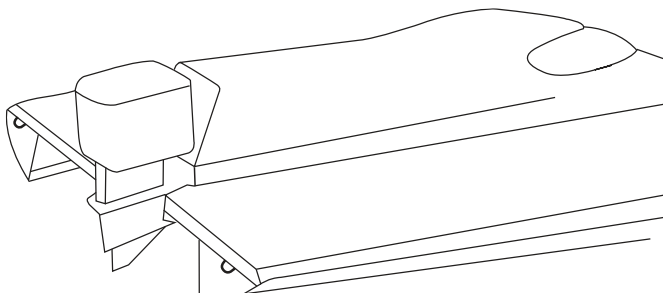

## 14. GENERAL

- 14.1. Drivers who have not committed to participate in all races of the Formula 1 World Championship, have to pay an entry fee of 670 € for each race.

All entries must be made by the team to the U.I.M.

All entry forms will include the text of the eligibility conditions and the following declaration will have to be signed by all team members « understanding that as a team member / driver I am participating in an U.I.M. Formula 1 Powerboat World Championship event which has ongoing international and sporting significance and in consideration of the acceptance of my participation therein, I agree to be filmed, televised, photographed and otherwise recorded during the World Championship under the conditions and for the purposes now or hereafter authorised by the U.I.M. and the Formula 1 promoter.»

- 14.2. All drivers uniforms and boats must feature series sponsors logo and badges.
- 14.3. The official film crew of the Formula 1 World Championship, will be contracted by the Formula 1 promoter.

All TV, film, media and commercial rights are the property of the U.I.M.

The U.I.M. contracted promoter handles the rights on behalf of the U.I.M.

Any organisation wishing to film or to use existing film must contact the promoter.

- 14.4. The official Formula 1 passes are the recognised access to race events.
- 14.5. The official U.I.M. Formula 1 logo must be prominently displayed on both sides of all participating boats.
- 14.6. The U.I.M. flag shall be flown from the podium if other flags are flown

Enlarged U.I.M. Formula 1 logo has to be prominently displayed on top of the podium during prize giving or during any other public function.

Any correspondence regarding the Formula 1 must be sent to the following address:

UNION INTERNATIONALE MOTONAUTIQUE  
STADE LOUIS II - ENTREE H  
1 AVENUE DES CASTELANS  
MC 98000 MONACO  
Fax: (377) 92-05-04-60  
E-mail: [uim@uimpowerboating.com](mailto:uim@uimpowerboating.com)  
Website: [www.uimpowerboating.com](http://www.uimpowerboating.com)

## **U.I.M. F2 WORLD AND CONTINENTAL CHAMPIONSHIPS**

1. ORGANISATION
2. RACE FORMAT
3. START
4. STOPPED RACE
5. INTERRUPTED RACE
6. RACE COURSE
7. CLASSIFICATION
8. EQUIPMENT
9. FUELS
10. SUPERLICENCES
11. YELLOW CARDS
12. PENALTIES
13. PROCEDURE FOR PROTEST AND APPEAL
14. SAFETY
15. GENERAL
16. INSURANCE

### **INTERPRETATION OF THE RULES - 200.02**

In all cases unforeseen by the international rules, the international jury is to adjudicate bearing in mind the spirit of the rules.

In case of conflicting rules, those rules concerning the Championship as published in the blue pages of the Circuit Rules Handbook are to prevail.

## **1. ORGANISATION**

- 1.1. The rights of organisation of F2 races and championships is owned and ruled by the U.I.M. which has granted the management of the competition to the Council.
- 1.2. The Council may update the rules whenever necessary.
- 1.3. The F2 daily management Committee is responsible for the championship daily management. This Committee is composed of the Promoter (1 vote), F2 Driver & Team Rep (1 Vote) U.I.M. Commissioner appointed to event (1 Vote) and the Formula Committee Chairman (1 vote or casting vote).
- 1.4. The F2 World Championships are governed solely by the U.I.M. international rules for circuit racing, as published in the white and blue pages of the Circuit Rules Handbook.
- 1.5. A permanent U.I.M. Commissioner will be appointed for the F2 World Championship series which will be held over a minimum of three rounds.
- 1.6. Any additional rule to these specific rules must be justified by national legal requirements and notified in the advance programme
- 1.7. Other Continental Championships will be run subject to the contract between the World Championship Promoters and the U.I.M.

## **2. RACE FORMAT**

- 2.1. Each F2 meeting counting towards the Drivers World Championship will include four separate parts to take place over a period of two consecutive days in accordance with the full U.I.M. Circuit rules for racing, classification, protests and appeal and by the specific rules listed below.

- 2.2. In case of force majeure the meeting may take place in one day.
- 2.3. If, through Force Majeur, less than 25% of the programmed total timed trial period is run, the grid positions will be established using the current championship order.
- 2.4. The programme for the event must include:
  - 2.4.1. Free practice (minimum 1 60 minutes);
  - 2.4.2. Two mandatory official timed trials each of 45 minutes duration;
  - 2.4.3. Two sessions of timed trials must be run except in case of “force majeure”.

## **LARGE ENTRY QUALIFYING SYSTEM**

A maximum of 24 boats will be allowed in any heat or race - if water registration is less, this will be specified in the advance programme.

If more boats are entered than the maximum water capacity, they will be qualified in accordance with the following method :

On the Sunday, a fixed number of drivers will automatically qualify for the World Championship round, based on the fastest time from their two timed trials.

Those not qualified will run in a single qualification race of 12 minutes on the Sunday morning, and a certain number will be qualified from that race. There will be no other qualifying races.

This system of automatic, and raced-for, qualification will be based on the water homologation maximum and the maximum permitted number of pre-registered entries accepted by the promoter, as indicated in the following table :

Maximum boats permitted in water homologation	24	20	18	16
Maximum permitted drivers pre-entered and accepted by organisation	40	34	30	26
Automatically qualified from Timed Trials 1 & 2	16	14	12	10
Number of drivers in qualifying races	24	20	18	16
Number of drivers going forward from qualifying race into the World Championship round	8	6	6	6
Drivers entered but failing to qualify	16	14	12	10

Depending on the number of drivers entered, and the water capacity, on Saturday there will either be :

Two free practices of 60 minutes, and four timed trial periods of 45 minutes each, with the entry divided into two groups after free practice by using odd and even order of the practice results.

or

Longer single sessions of free practice and timed trials will be organised for the whole entry to participate in at the same time.

In which case the Commissioner will reserve the right at any time to prevent boats leaving the jetty to participate in timed trials depending on the amount of traffic already on the circuit.

Boats may indicate their readiness to start practice runs by parking in a designated waiting area only, and their radio man will be informed when the driver can join the circuit. Boats wishing to make a practice run cannot wait in any area other than the designated one.

2.4.4. The F2 race [ approx. 30 minutes duration, but with a limit of 90 minutes including any re-starts ]

2.5. A typical programme would be :

## **SATURDAY**

08.00 to 11.00 Registration and scrutineering

Compulsory drivers and radio men roll-call and meeting, at race headquarters, penalised if not present.

Free practice period [60 mins].

First timed trial [45 mins] Each boat entitled to only 17 times past timing control.

Second timed trial [45 mins] Each boat entitled to only 17 times past timing control.

Each boat is allowed to pass the timing control a maximum of 17 times during each time trial session.

Match Races, covered by separate rules.

## **SUNDAY**

Compulsory drivers and radio men roll-call and meeting, at race headquarters. Penalised if not present.

Warm-up [45 mins].

Qualifying race.

Presentation parade lap.

Race.

- 2.6. Detailed information about practice, timed trials, Match Races, and number of boats allowed on the circuit must be given in the advance programme
- 2.7. If a race is shortened due to force majeure, it is at the discretion of the O.O.D. and the U.I.M. Commissioner to alter the time table and if necessary the course layout accordingly. In the event of no qualifying times being achieved, the grid will be drawn-up in accordance with the current championship positions.
- 2.8. No entry shall be considered official until the boat has passed the scrutineering and documents controls
- 2.9. Calculating the number of laps is as follows : Add up the final qualifying times for the boats in positions 5 to 14. Divide by 10 to



get an average time. Divide the average time into the time of the race in seconds. This will give the number of laps. You may round up or down to nearest 5.

### 3. START

- 3.1. The fastest time recorded for each boat by the official timekeepers, during official timed trials, shall determine the starting positions of boats for the race or the qualifying heats if used.
- 3.2. The start shall be a dead engine jetty start as described in rule 307: Dead engine jetty start.
- 3.3. A course boat will be stationed at a convenient point for the last part of the parade lap, and will show a green flag; at which point the driver can use full revs to clear his engine prior to moving directly into his grid position on the start jetty.
- 3.4. Boats should be drawn up stern first with dead engine, to a jetty, floating pontoon or beach. The start must be with the current. The distance between the starting line and the first turning buoy must be at least 300 metres.
- 3.5. When the pontoon marshal is satisfied that all drivers are ready to start, with engines stopped, he will raise a green flag and the O.O.D. will initiate the start procedure. He instructs the starter to raise a 30 seconds board (min. 80 x 80 cm, figures 60 x 10 cm), and when the remote operated start lights are used, blue flashing lights will be operated during the 30 second period.
- 3.6. After 30 seconds this board will be lowered the blue flashing lights switched off, and the red light will be switched on. After 5-12 seconds the red lights are switched off, this is the signal to start.
- 3.7. These drivers rotating their engines (even with ignition switched off) prior to the red lights going off lose one lap.

- 3.8. This lap will be deducted at the end of the race.
- 3.9. The starter may decide if he judges it necessary, to cancel the start by showing the red flag and recommence the starting procedure.
- 3.10. The start jetty must have a minimum length of 70 metres or be equal to 4 metres multiplied by the maximum number of boats permitted to race, [whichever is the greater] and must be at least 1.5 m wide.
- 3.11. All start pontoons must be sufficiently angled (minimum 50 degrees) such that the pole position has a significant advantage towards the first turn buoy, compared with the last positions on the starting grid. The plan of the circuit (including the position of the start pontoon) must be sent to the commissioner 60 days in advance to get his approval.
- 3.12. Any boat not starting must be returned to shore by the driver's own efforts. Any crew member swimming out to a boat will cause his entry to be disqualified.
- 3.13. Drivers failing to start will wait at the dock until signalled by the pontoon marshal to fall in behind the field.
- 3.14. Before the start of the first race, each driver shall complete a lap of the course immediately after his name has been announced, so that he may be introduced to the public.
- 3.15. An overlap may only be established when two boats are on the same course or approximately on the same course and the overtaking boat has no longer a free choice on which side he shall pass.

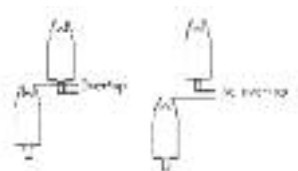

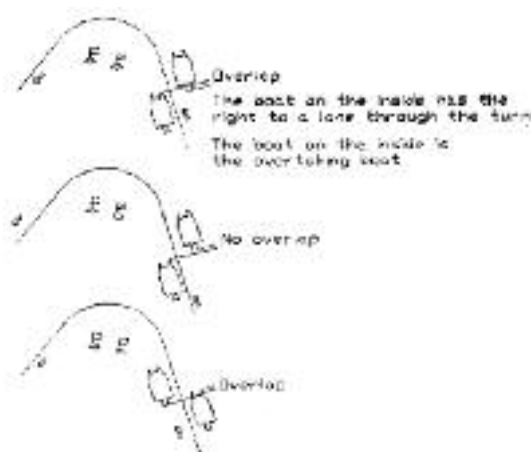

## 4. STOPPED RACE

- 4.1. In the event that a race is completely stopped rule 311 will apply.
- 4.2. Upon showing the red flag, drivers must return slowly under their own power to the start pontoon [or other position on the circuit notified by the U.I.M. Commissioner during drivers' briefing].
- 4.3. Drivers receiving outside assistance at any point during the race (whether the race has been stopped for an incident or not) will be disqualified.
- 4.4. Boats that have broken down and received outside assistance by being pulled to the infield, or off the race course, will be towed to the trailer or the starting dock only during a "race stop" condition and if pick-up boats are available.
- 4.5. Repairs are allowed at any time during the race, with the exception that replacement of the crankcase and the cylinder

block is prohibited. Repairs are not allowed on the race course using outside assistance.

- 4.6. Only if a boat reaches the pontoon on its own power, repairs can be carried-out either while the boat is completely in the water or on its trailer, at the sole discretion of the Pontoon Marshal. Further instructions for the repair areas may be given at drivers briefing.
- 4.7. No repairs are allowed on the start pontoon during the line-up and start or re-start preparations.
- 4.8. Drivers may carry-out their own repairs on their boats in accordance with the rules. The driver's two nominated pontoon mechanics and the official crane driver do not count as outside assistance.
- 4.9. In the event of a restart a boat being repaired must be ready to take its position on the grid as directed by the Pontoon Marshal. If the boat is not ready to take its position, it must start at the end of the pontoon.
- 4.10. Hulls and motors must be sealed after scrutineering and before practice. In races with several restarts, substitution of hull or motors between the restarts or during the race is prohibited.
- 4.11. To qualify for points, a stopped race must be restarted if 70% of the total distance specified for the race has not been covered at the time the race is stopped.
- 4.12. The number of laps completed + 1 lap per restart will be deducted from the restarted race.
- 4.13. Should there be a restart, starting positions will be determined by the order of the end of the lap prior to the race being stopped.
- 4.14. All boats which are ready to race, may start in a restarted race.

## 5. INTERRUPTED RACE - PACE BOAT RULES

- 5.1. The Organiser may interrupt the race for any reasons of safety or emergency services access, and in which case the rescue boats and race control will show yellow flags.
- 5.2. At this signal all drivers must immediately slow down and not overtake. Any overtaking, 5 seconds after the yellow signal has been given, will be penalised by 1 lap. The leading boat, or a specially designated boat, will act as pace boat, and run at slow speed.
- 5.3. When the race course is clear, only the yellow flag at race control will be continued to be shown.
- 5.4. All boats maintain their position at slow speed (approx. 4000 rpm) until race control raises the green flag. It is the responsibility of the team managers to ensure that their boat(s) are in the correct position at the restart.

If a boat, in any position on the water is judged to be speeding or causing a hazard under the yellow flag during a pace boat situation, they may receive a drive through or 1 lap penalty.

- 5.5. When a rolling re-start is used, the U.I.M. Commissioner can restart the race by showing a green flag at any point on the race course. The first 10 boats must be in their correct positions before the race can be restarted. The position of the boats for the rolling restart will be that of their race positions on the lap before the yellow signal was given.
- 5.6. Boats which do not restart in their correct position, will be given a one lap penalty..
- 5.7. During the yellow signal situation, a boat may leave the race course but must re-join the race behind the boat running in last position.
- 5.8. In races run with the pace boat system in operation, a yellow flag will be used by race control and the rescue boats to indicate a hazard when displayed stationary, and extreme caution to be

exercised by drivers when waved vigorously. No overtaking permitted during yellow flag status.

## **6. RACE COURSE**

- 6.1. Course and safety rules shall be those of the U.I.M. applicable on the date of the race unless specified otherwise by these rules.
- 6.2. The length of straight between any two turning buoys is to be a maximum of 850 metres. The boundaries of the water on which practice and racing are allowed to take place must be defined in the advance programme.
- 6.3. In cases of force Majeure, any changes to the course must be agreed by the Daily Management Committee members present at the event and the new course presented to the drivers. If the course is changed from its original specifications then free practice may be offered to the drivers if the time schedule permits.
- 6.4. The pit area should be sufficiently large to prevent boats being craned into the water over other boats.
- 6.5. There must be a minimum of 2 cranes.

## **7. CLASSIFICATION**

- 7.1. The boat placed first will be the one having covered the scheduled distance in the shortest time.
- 7.2. All boats will be classified by taking into account the number of complete laps they have covered and for those which have completed the same number of laps, the order in which they crossed the finish line.
- 7.3. The number of laps completed during the eventual restarts will be taken in account for the classification.
- 7.4. The points will be awarded to the first 10 classified drivers on the condition that they have completed at least 70 % of the numbers

of laps covered by the winner (rounded down to the nearest whole number of laps). Boats having done 90% or more laps but do not cross the finishing line after the winner has crossed will be classified after those boats that have done the same number of laps but that also cross the finishing line after the winner.

- 7.5. The leading boat must have completed 70 % of the number of laps counting for the race.
- 7.6. If the race cannot be restarted due to “force majeure” then the points will be awarded in accordance to the following scale:
- |  |             |
|--|-------------|
| 7.6.1. 70% or more of the total race completed | full points |
| 7.6.2. less than 70%                           | halfpoints  |
| 7.6.3. less than 35%                           | no points   |
- 7.7. The first six classified boats are to be weighed when coming out of the water. The weighing of the boats can not be protested. The scales will be available before the meeting commences.
- 7.8. Points will be awarded to the first 10 classified drivers in accordance with the following finishing points scale:
- |         |           |
|---------|-----------|
| First   | 20 points |
| Second  | 15 points |
| Third   | 12 points |
| Fourth  | 9 points  |
| Fifth   | 7 points  |
| Sixth   | 5 points  |
| Seventh | 4 points  |
| Eight   | 3 points  |
| Ninth   | 2 points  |
| Tenth   | 1 point   |
- 7.9. The overall classification for the F2 Drivers' World Championship shall be established by the addition of all points obtained by each driver in each of the races counting towards the championship.
- 7.10. In the case of a tie, the number of first places in these races shall be considered, then the second places, etc...

- 7.11. Immediately after the race:
- The winner will complete a lap of honour;
  - Presentation of trophies to the first 3 drivers on the official podium. This presentation is only based on a provisional classification, and is subject to confirmation after scrutineering and consideration of any protests or appeals.
- 7.12. At the last race of the series U.I.M. will provide 3 medals (gold, silver, bronze) to be given to the first three in the overall classification of the World Championship.
- 7.13. These medals do not replace the normal prizes (art. 108.01 and 322).

## **8. EQUIPMENT**

### **8.1. HULL**

- 8.1.1. Hull must be a catamaran type, based on twin hulls, but may be of completely free hydrodynamic and aerodynamic design.
- 8.1.2. Must conform to the general U.I.M. rules 501; 502; 503; 504; 508; 509; 542.05 and these F2 rules.
- 8.1.3. Boats configured to work on the hydrofoil principal will not be eligible.
- 8.1.4. The minimum hull length is 4m80.
- 8.1.5. The minimum weight of the boat and driver as raced is 513 kg.
- 8.1.6. Measured in accordance with rule 542.12.
- 8.1.7. The front 305 mm. (12 inch) of the cockpit and pickles should not be made of a material which would not allow controlled deformation to reduce G forces on frontal impact (mandatory).
- 8.1.8. Each wing mirror must have minimum size of 60 sq. cm and be bolted on 2 points to assure proper mounting.



- 8.1.9. Radios in boats are mandatory and a full radio check of each boat will be part of technical scrutineering in order to guarantee that all radios are working. The radioman must be present at race control whenever his boat is on the course. In order to guarantee clear communication between the Team Managers and the U.I.M. Commissioner, all Team Managers must speak English.
- 8.1.10. The homologated delayed operation buoyancy airbag is mandatory.
- 8.1.11 ***Hull, sponsons, and powerhead replacements and other parts are allowed after scrutineering, up until the end of timed trials, but any changes to be made must be immediately notified to the U.I.M. technical Commissioner for re-scrutineering and sealing and technical inspection of units removed.***
- 8.1.12 ***Any replacement of boat or sponsons after qualifying time trials will result in all previous times achieved being cancelled, and the replacement boat or sponsons will be considered as a new entry, requiring full scrutineering. If no timed practice opportunity remains, the boat will start from the end of the grid.***

## **8.2. MACHINERY FOR SST.120 ENGINE MODEL ONLY**

- 8.2.1. Only engines qualifying to the SST120 rules will be eligible for F2. Engines will be measured and checked against the SST120 data sheets.
- 8.2.2. Maximum engine displacement 2050cc.
- 8.2.3. All cowling and engine graphics and colours shall be as OEM, with updating to later models allowed only as a complete OEM design.
- 8.2.4. Engine wiring can be changed to a 24-volt starting system.
- 8.2.5. Gearcases may have their outside surfaces re-profiled, however they must meet the minimum dimensional requirements of the

Engine Specification sheets. The outside surfaces of the gearcases may be either painted or unpainted. If they are painted, the colour of the paint must be the same as the original factory motor colour. If the gearcases are unpainted, any surface finished is acceptable.

- 8.2.6. It is permissible to remove, or render inoperable, the engine fuel primer system and plug holes opened-up by removing the system.
- 8.2.7. A maximum of 3 damaged cylinders may be re-sleeved using sleeves from any manufacturer. Sleeve material and the machined port opening's shape and dimensions must all be as original equipment.
- 8.2.8. Reeds may be of any material or design.
- 8.2.9. Cylinder block exhaust port outlet openings may be remachined to the maximum dimensions shown in the Specification Sheet. Only machined openings are acceptable, machined in the same manner as the originals (prior to assembly) in situ hand grinding or blending of any sharp or misaligned edges is not permitted.
- 8.2.10. An Outboard motor is defined as a complete internal combustion power and propulsion unit that can be attached to a boat and which can be lifted bodily from the hull as one unit. Batteries used for ignition and starting, tachometer, throttle control and steering arrangement are excepted.
- 8.2.11. A manufacturer of outboard motors for F2 Racing is the one who filed specifications and is responsible for the original design and manufacture of the following: crankshaft, connecting rod, cylinder head, cylinder, crankcase, gears and valving arrangement, and who complied with such other requirements as provided by these rules.
- 8.2.12. Motors must be the product of a recognized manufacturer engaged in the production of outboard motors offered for sale to the general public.

- 8.2.13. There shall be no alterations of parts with the exception of spark plugs, carburettor jets, and propellers, or specific parts approved by the Technical Commission. The intention is to race the engine exactly as manufactured and without special performance boosting accessories.
- 8.2.14. No special parts or interchange of parts will be allowed, unless approved by the Commission.
- 8.2.15. The trim tab, thrust and locking washers may be altered or removed from the lower unit to permit the use of any propeller, thrust washer or nut.
- 8.2.16. Cylinder head and power head attaching studs may be substituted for bolts.
- 8.2.17. Electronic engine RPM limiting devices may be over-ridden or rendered inoperative.
- 8.2.18. Engines (Outboard) as referred to in these rules shall be defined as outboard models which:
- Are manufactured in annual or model year quantities of more than 25 units.
  - Are not necessarily intended for sale and to be used by the general non-racing public.
  - Are not necessarily advertised through the same media, in the same publications and given the same prominence as the manufacturer's other engines.
  - Are not necessarily distributed through the manufacturer's normal channels.
  - Accessory gearcase, as submitted by the manufacturer, may be used in these engines provided that they are built in a total quantity of no less than 25.
- 8.2.19. Exhaust stacks not contained in the driveshaft housing will not be permitted.

- 8.2.20. Engines may only be run in the configuration that they were homologated in by the Technical Committee.

### **8.3. REPLACEMENT PARTS FOR SST.120 ENGINE MODEL ONLY**

- 8.3.1. Only such parts shall be permitted as are standard production OEM parts used on the motor as the purchaser may obtain it from the dealer as a stock item or electrical or electronic products as approved by the Technical Commission, and published and available to the general public through dealers. These products cannot provide any performance advantage over original OEM parts.
- 8.3.2. No replacement part for current production motors shall be considered standard production until this part appears on current production motors which can be purchased from the dealers.
- 8.3.3. Any replacement part for motors no longer in production shall be approved only after the part being replaced is no longer available for the motor model from the manufacturer or is specifically approved by the Commission.
- 8.3.4. Final approval of non-OEM electrical or electronic parts approved for use in F-2 racing shall not be given until all provisions of the rule have been complied with, and until such time as the manufacturers have built at least 250 units of the part submitted for homologation.
- 8.3.5. For non-OEM electrical or electronic parts, the manufacturer must follow the same rules as specified for motor manufacturer registration with respect to submission of specifications to the Commission and the time period for which the parts are approved.

### **8.4. MOTOR MODIFICATIONS**

- 8.4.1. There shall be no blueprinting or modifications whatsoever to the motor as furnished by the manufacturer other than:

- 8.4.2. Any carburettor jets, spark plugs or propellers may be used provided other parts are not altered to accommodate them with the exception of the trim tab.
- 8.4.3. Only such parts shall be permitted as are used by the motor manufacturer on the particular model as built on the production line. Modifications covered by a manufacturer's service or engineering bulletins are legal seven days after the date of any such bulletin and approval by the Technical Commission, provided all direct purchasers of affected engines are notified by mail as well as all inspectors, followed by printing in the U.I.M. Bulletin at the next opportunity. In the event the manufacturer is unwilling or unable to meet these criteria, modifications covered in such bulletins will be legal after printing in the Propeller.
- 8.4.4. Oversize pistons furnished by the manufacturer of an outboard motor may be used in the model for which they are furnished. The bore of the engine may be enlarged by the amount that the oversize pistons differ from the standard size pistons. An additional total 0.005 inch enlargement of the bore will be allowed for bore enlargement due to wear or re-matching errors, or measuring tolerance. Under no circumstances may the bore be enlarged more than 0.035 inch over the original dimension. It is not permissible to chromium plate cylinder walls unless the motor manufacturer uses chrome plating of cylinder walls as standard production procedure on that particular model.
- 8.4.5. Tachometer, fuel and water pressure, and temperature (including EGT) gauges may be installed if desired.
- 8.4.6. The attachment of a steering bar or its equivalent may be accomplished at any point or points on an engine. Any cowlings or plates removed may be cut and, must be replaced. Any openings created by this operation must be sealed to prevent the engines from pulling in air. Studs or bolts may be exchanged to secure steering bar.
- 8.4.7. Throttle return springs will be allowed on engines, however no modifications to the engine will be permitted to install same; no

drilling of holes, etc. Mounting links may be attached with present fasteners.

- 8.4.8. Isolation Mounts: Only those supplied by the engine manufacturer as original equipment or through the service group are acceptable.
- 8.4.9. Any adjustments of mixture control, throttle and shift linkage will be allowed.
- 8.4.10. Any mechanical adjustments of spark advance will be allowed provided no modifications are made either to the spark advance system or the engine as manufactured.
- 8.4.11. Safety tilt switches and safety starting switches may be disconnected or by-passed.
- 8.4.12. Fuel pumps, filters, heat exchangers or auxiliary tanks may be installed in the boat provided the use of same entails no modification to the engine and fuel lines so used to connect to the fuel connector provided with the engine.
- 8.4.13. The attachment of a power trim system may be accomplished at any point or points on an engine. Only those parts of the production motor interfering with the attachment and function of the trim system may be altered or removed.
- 8.4.14. Bead blasting will be allowed at the block and crankcase interface only. No other internal parts will be allowed to be bead blasted.

## **8.5. SST.200 ENGINE MODEL**

- 8.5.1. *The SST.200 engine, unaltered, is a legal engine in F2.***
- 8.5.2. *The SST.200 engine may not be modified in any manner.***
- 8.5.3. *Maximum engine displacement 2550 cc.***
- 8.5.4. *Exchange or replacement of the engines PCM (electronic unit) may be demanded by the O.O.D./scrutineer/U.I.M. commissioner at any time during a race event.***

## 9. FUEL

- 9.1. General fuel rules in 508 will apply.
- 9.2. Fuel will be supplied by the organiser in conformity with rule 508.01.

## 10. SUPERLICENCES

- 10.1. The nationality of a driver is the nationality of the N.A. which issued the international racing licence to the driver. Medical and immersion tests can be done in other countries if the issuing N.A. agrees. The flag is the one of the issuing N.A. of the international licence as above. The request for the U.I.M. Superlicence must come from the N.A. which issues the international racing licence.
- 10.2. Drivers must hold a U.I.M. super licence before entry will be accepted. No current F1 contracted driver is allowed to participate in Formula 2 World Cup/Championship.  
  
A driver who exceeds 50 years of age in the season for which he is applying for a superlicence, must produce the medical certificate including all detailed examinations which will be submitted to a doctor approved by the U.I.M.
- 10.3. Any new driver must be vetted in practice by the U.I.M. Commissioner and the drivers delegate to the U.I.M.
- 10.4. The super licence is required for F2 together with the NA international Licence. No other membership is required.
- 10.5. To obtain a superlicence, a driver must have participated in 6 circuit races in any catamaran O or S class or hydrocat min 500 cc. Definition of a race during a race weekend: even if several heats take place, the race weekend with all heats or races counts as one race only. The National Authorities are fully liable for the sports c.v. that they submit for their drivers. The full race results of each race must be supplied since the drivers must have done at least 6 races with 70 % of the total distance of each race event.

- 10.6. The superlicence is provisional for the first 3 races and can be withdrawn at any time during the first 3 races by a committee composed by the O.O.D., the U.I.M. Commissioner and the Drivers representative. When a super licence is withdrawn, next application can only take place for the next season.
- 10.7. The application for a super licence must be made by the National Authority of the driver concerned and lodged with the U.I.M. 4 weeks before the first event the driver wants to participate in. The superlicence fee of 120 Euro. will be doubled for applications received beyond the 4 weeks deadline.
- 10.8. The application must be accompanied by:
- The sports career of the driver, mentioning the results obtained in the qualifying events;
  - U.I.M. medical documents, as per appendix to these rules, giving the information required by the U.I.M. rules 205.03/ 205.04 / 205.04.1.

General Recommendation for F2 superlicence holders concerning physical fitness

- Cardiovascular training (endurance training) as jogging, cycling, rowing etc. twice a week - minimum 20 minutes without any interruption. Any sports activity which has “stand still” during the activity such as soccer, tennis or any ball sport is not suitable for the endurance training, but recommended as additional training;
  - Training to build up muscles for neck and back at least twice a week;
  - The immersion certificate (ref 205.05);
  - A photo;
  - The fees will be fixed by the General Assembly;
  - A current rule book will be given to the driver along with the super licence.
- 10.9. The National Authorities are responsible for the information given.



- 10.10. The application will be examined by the Secretariat of the U.I.M., with the assistance of the Formulae Committee who will decide on its acceptability.
- 10.11. The decision of the Formulae Committee on all matters concerning superlicences is final and cannot be protested or appealed.

***The decision of the Formulae Committee on all matters concerning superlicences is final and cannot be protested or appealed,***

***If any F2 superlicence holder participates in a non-sanctioned U.I.M. international event, their superlicence will be withdrawn.***

***The driver may re-apply for the superlicence after 12 months from the date the original superlicence was withdrawn.***

- 10.12. The super licence is valid for 1 year (from January 1st or from the date of issue to December 31st).
- 10.13. For renewal of the super licences, the National Authorities must, before the end of December, send the U.I.M. a list of the drivers for whom a renewal for the following year is required.

## **11. YELLOW CARDS**

Yellow cards given in other Formulae Series (F1) will be taken into account on the yellow card listing.

- 11.1. Yellow cards can only be given for the behaviour on the water.
- 11.2. A yellow card will be confirmed on a form which will be posted with the results. The pilot has 60 minutes to protest to the jury.
- 11.3. If the protest is not upheld, he can appeal. Protests and appeals must be lodged according to U.I.M. rules.
- 11.4. A yellow card can be given by:

- \* the Officer of the Day;
  - \* the U.I.M. Commissioner.
- 11.5. The yellow card can be given according to the following:
- 11.5.1. Up to two yellow cards at a time for dangerous driving;
  - 11.5.2. Red card for extremely dangerous driving and unsportsmanlike behaviour.
- 11.6. A driver who has been given three yellow cards or a red card loses right to take part in the next event of the World Championship or Continental Championship (current season or following season). When a penalty of not racing at the next race has been satisfied, the 3 yellow cards or the red card are deleted by the application of that penalty.
- 11.7. All cards will remain valid for the four following events of the Championship as from the date on which the last card was delivered.
- 11.8. Participating in training, timed trials and final race will be considered as having completed one event.
- 11.9. An organiser/N.A. who has given one or more yellow cards to a driver must inform U.I.M. by telefax or mail within 3 days. U.I.M. will inform the next organiser/N.A. of a World Championship race or the Continental Championship about the issue of such yellow cards. When a driver has completed 4 races without yellow cards, his previous yellow card(s) will be deleted from the listing.
- 11.10. Yellow cards issued must be mentioned in the commissioner's report which must be distributed to all members of the relevant U.I.M. Formula commissioners panel.
- 11.11. Temporary suspension: see article 406.05

## **12. PENALTIES**

- 12.1. Penalties will be issued to drivers in accordance with other U.I.M. rules and/or with the following list :

INFRINGEMENT	FINE (IN Euro).
12.2. Not present at drivers meeting roll call	200
12.3. Not under crane when called forward	150
12.4. Not respecting exit lane	100
12.5. Not respecting entrance lane	100
12.6. Radio man not at timing control	200
12.7. Not lining up within 20 seconds on jetty	150
12.8. Not in correct position on parade lap	100
12.10. Destroying each turn buoy (free Practice and time trials)	200
12.10a. Destroying 1 <sup>st</sup> buoy (race only)	1 lap and 200
12.10b. Destroying 2 <sup>nd</sup> buoy (race only)	DSQ and 200
12.11. Overtaking under yellow flag	1 lap
12.12. In visiting pit during yellow flag	last position
12.13. Not in correct position under yellow flag/re-start	1 lap
12.14. Taking technicians on boat on the course (excl. the race winner)	200
12.15. Bringing own racing fuel to race venue	300
12.16. Not respecting instructions of U.I.M. Comm / and or Officials	DSQ, or 1 lap or 200
12.17. Non operative airbag system due to closed valve of air bottle, no connecting of roll over switch, taping or sealing of the deck plate system	1500
12.17a Any part of the Airbag system activates during time trials or free practice	Black flag

- 12.17b Any part of the Airbag system activates during a race Black flag and DSQ
- Not closing safety belts during time trials, free practice and the race 5000
- Not connecting fuel pump lanyard to life jacket 1000
- 12.18. The Formula Committee has the right to fine a driver (money or suspension) for any infringement of the rules or any abusive or unsportsmanlike behaviour.
- 12.19. The Daily Management Committee may decide to apply a “drive-through” immediate-penalty in cases that carry a 1 lap penalty. This will be announced in the advance programme and/or the driver’s meeting. The drive-through penalty can only be taken under Green Flag conditions. This will be communicated from the Commissioner to the driver via his radio person and a board flashing the driver’s boat number. The driver must complete the drive through penalty within three green flag laps of the announcement. He must leave the course at the pit entrance buoy and enter the race course at least at the back of the field maintaining 4000 r.p.m. during the penalty lap under the green flag. Failing to comply will result in disqualification for the race.

### **13. PROCEDURE FOR PROTEST AND APPEAL**

- 13.1. A protest can be lodged in accordance with the 400 jurisdiction rules either by the driver or the team manager. Appeals will also be handled in accordance with the 400 jurisdiction rules.
- 13.2. The delay to appeal is counted from the moment of the communication of the Jury decision to the interested parties and it is 48 hours.
- 13.3. The 24 hours of the Sunday do not count within the 48 hours to appeal. Address, telephone and fax should be clearly mentioned on the appeal so that the U.I.M. can send any correspondence directly to the driver with copy to his N.A. The driver may agree to forego an Appeal Committee meeting and for the appeal to be

handled through telephone and fax - if possible - in order to minimize the costs of the appeal.

## **14. SAFETY**

- 14.1. Drivers must wear a floatation vest incorporating pants, and so constructed at the shoulders and the legs that a driver can be easily pulled of the cockpit. Floatation overalls (orange colour is recommended) are a permitted alternative to life jackets, but must incorporate extraction handholds for driver removal from cockpit.
- 14.2. The homologated delayed operation buoyancy airbag is mandatory. The maintenance of the airbag system is the responsibility of the team.
- 14.3. Drivers taking technicians on their boats will be penalised.
- 14.4. The winner can take his technicians for the victory parade lap only. A rescue boat will follow the winning team at close distance.
- 14.5. Hans device is recommended for F2 see 509.08
- 14.6. Seats are mandatory for F1 / cockpits and very strongly recommended for all other cockpit classes (for description see 509.08).
- 14.7. F2 cockpit boats must have U.I.M. registered safety crash boxes installed on both sides of the safety cockpit.
- 14.8. One radio man is required per boat.

## **15. GENERAL**

- 15.1. The official U.I.M. sticker is mandatory and must be visibly displayed on all participating boats.
- 15.2. All TV, film, media and commercial rights are the property of the U.I.M.

- 15.3. The U.I.M. contracted promoter handles the rights on behalf of the U.I.M.
- 15.4. Any organisation wishing to film or to use existing film must contact the promoter.

## **16. INSURANCE**

- 16.1. The advance programme must contain following information:
- 16.2. Terms and conditions of a mandatory insurance for personal and material damage on third parties, competitors included
- 16.3. The minimum limit of coverage required
- 16.4. The type of risks to be covered by the insurance
- 16.5. Whether insurance from other National Authorities are accepted and if they are, in which language they must be drawn up
- 16.6. The amount of insurance fees to be paid on the spot.

## **17. FINANCIAL CONDITIONS OF A F2 WORLD EVENT**

- 17.1. Prize fund and travel costs will be furnished by the promoter and agreed directly with the drivers
- 17.2. Any correspondence regarding F2 must be sent to the following address:

UNION INTERNATIONALE MOTONAUTIQUE  
STADE LOUIS II - ENTREE H  
1 AVENUE DES CASTELANS  
MC 98000 MONACO  
Fax: (377) 92-05-04-60  
E-mail: [uim@uimpowerboating.com](mailto:uim@uimpowerboating.com)  
Website: [www.uimpowerboating.com](http://www.uimpowerboating.com)

**U.I.M. FORMULA 3 WORLD CHAMPIONSHIP**

**THE FORMULA 3 WORLD CHAMPIONSHIP TITLE IS SUSPENDED  
UNTIL A VIABLE FORMULA AND ANNUAL RACE FORMAT  
IS ESTABLISHED**

## **U.I.M. FORMULA 500 WORLD CHAMPIONSHIP**

«Dieter König Memorial»

1. ORGANISATION
2. RACE FORMAT
3. CLASSIFICATION
4. STOPPED RACE
5. YELLOW CARDS
6. COMMITTEE OF APPEAL
7. SAFETY
8. GENERAL

### **INTERPRETATION OF THE RULES - 200.02**

In all cases unforeseen by the international rules, the National Authority is to judge bearing in mind the spirit of the rules.

In case of conflicting rules, those rules concerning the series are to prevail.

#### **1. ORGANISATION**

The organisation of F500 races and championships is owned and ruled by the U.I.M.

The Council may update the rules whenever necessary, only if the Formula is promoted by a contracted promoter.

Meetings in Formula 500 are reserved to boats of the O series, equipped with 351 cc to 500 cc outboard engines.

The championship is open to all drivers (their number per National Authority being unlimited) who will produce evidence that they have participated satisfactorily in at least 5 international or national races in the O series.



The official U.I.M. sticker is mandatory and must be affixed on all participating boats.

## **2. RACE FORMAT**

The Championship includes a minimum of 4 and a maximum of 6 races organised in different countries, with a minimum interval of two weeks between races if possible. The U.I.M. reserves the right to allocate the Championship even if the minimum number of races are not held or awarded points.

Applications to hold a F500 event will be allocated in the normal way (rule 108.01, but using the English names of the country applying) except that one National Authority can be allocated two events provided the maximum number has not been requested by other National Authorities.

***Except a maximum of 4 races to be included in Water Festivals takes priority during allocation by Cominsport.***

If 6 races are run with points allocated, the 5 best results count for the final classification.

It is recommended that all races use a jetty start (rule 307).

### **CIRCUIT:**

The length of the lap will be included between 1500 and 2000 meters;

- The length of a qualifying heat will be included between 8 and 12 km;
- The number of boats authorised on the circuit must be announced in the advance-programme.

### **RACE:**

Each race will include 3 final heats.

If the number of drivers present exceeds the number admissible on the circuit, qualifying heats will take place.

The composition of qualifying heats will be determined by the classification of official timed trials: drivers with an odd position (1, 3, 5,

etc...) will be put together in one series, drivers with an even position (2, 4, 6, etc...) in the other series. Drivers who have not participated in trials will be split between the qualifying heats.

Each series will run a selection heat and certain drivers a supplementary heat.

Example based on the presence of 30 boats on a circuit authorised for 14 boats:

3 series of 10 boats will be formed:

At the end of the selection races for these series, the 4 first of each series will be selected ( $3 \times 4 = 12$ ).

The supplementary heat will be run by the 14 non selected drivers with the greatest point totals, the two first of this heat will be selected to participate in the final ( $1 \times 2 = 2$ ) giving a total for the final of  $12 + 2 = 14$  drivers. ***They are positioned at the lower end of the jetty for the first heat.***

If necessary, after all the qualifying races, the organisers reserve the right to make up the number of boats in the final races to the maximum permitted from the repechage heat, when any qualified driver indicates that they cannot participate in the final heats. This cannot be done after the first heat.

An interval of at least one hour will be mandatory between final heats and between the last qualifying heat and the first final heat.

If the qualifying heats are of a different number of laps-positions on the jetty for the final races are from lap times - if not available then the positions in which they finish their heat will be intermingled - the first being the winner of the longest qualifying heat.

#### **START:**

***The distance between the start line and the first turn mark must be at least 300 metres in a straight line.***

***At dead engine starts, the drivers must keep their relative positions to the first turning buoy and through completion of that turn, not interfering in the path of competing boats. Sufficient room on the***

***inside must be left by the leading boat, if not pole, to allow others higher on the jetty to negotiate the turn. From then on it is the ordinary rules of the road. The inclusion of a mandatory starting buoy for safety reasons does not count as the first turning buoy when keeping your lane.***

***Breaking this rule will result in one or more of the following penalties, which are disqualification, one lap penalty or a yellow card, depending on the severity.***

***It is prohibited to stand up during start and while racing.***

***At all dead engine starts at international titled races, the start may be videotaped (or similar). This is to be done from a position as high as possible and/or from a place in extension of the start lane.***

### **3. CLASSIFICATION**

The classification of the race will be drawn-up by adding up each driver's points in every final heat (scale referred to in article 318.01).

In order to obtain a general classification of the Championship, the first drivers classified in races taken into account in a championship will be given points as follows:

1st: 20 points	6th: 10 points	11th: 5 points
2nd: 17 points	7th: 9 points	12th: 4 points
3rd: 15 points	8th: 8 points	13th: 3 points
4th: 13 points	9th: 7 points	14th: 2 points
5th: 11 points	10th: 6 points	15th: 1 point

The winner of the Championship will be the driver who will have accumulated the highest number of points.

In case of a tie, the number of first positions, second positions etc. will be successively taken into consideration.

In case of a new tie, all U.I.M. points collected in all races counting for the Championship will be added up (scale referred to in article 318.01) applied to the general classification of each event.

At the last race of the series U.I.M. will provide three medals (gold, silver, bronze) to be given to the three first classified in the general classification.

#### **4. STOPPED RACE**

A stopped race is a race which has been interrupted by the Officer of the day after the start. Stopping the race is decided by the Officer of the Day for reason of force majeure of which he is the sole judge. A race must be stopped when any body is in the water as a result of an accident (blow over, roll, submarining, collision, etc...) as the continuation of the race constitutes a danger to those involved.

A stopped race may only be repeated twice.

- a) A stopped race must be repeated twice if necessary
- b) When the leading boat has completed less than 70 % of the required laps the race shall be re-started.
- c) First restart, full number of laps, refuelling is allowed.
- d) Only drivers scored on the lap before the stoppage, can restart.
- e) If a first re-started race is also stopped before 70 % of the required laps have been completed by the leading boat, the race shall have a second start.
- f) A second restarted race does not allow refuelling.
- g) Laps for a second restarted race shall be:  
 Add 1 lap to the full number of laps completed before the stoppage  
 - take these away from original number of laps - new race distance.  
 Example: restarted race stopped on lap 4 in an 8 lap race: 3 laps completed + 1.  
 $8 \text{ laps} - 4 = 4 \text{ laps for second restarted race}$
- h) If a second restarted race is also stopped: results - up to 35 % of required laps 50 % points. 35 % and over = full points.

- i) Any penalty incurred in any race is carried forward to any restart of that race.

If two repeated races are provided for in the advance programme, the first one must be a complete race (total number of foreseen laps) and the second one according to the following format.

If only one repeated race instructions will be given in writing to the drivers during a special drivers meeting.

No refuelling is allowed between a stopped race and a repeated race, except if the repeated race is a complete heat.

Only the drivers scored at the lap before the stop, are allowed to restart.

Points will be awarded according to the following system:

up to 35% of the distance	1/2 points
above 35% of the distance	total points

## 5. YELLOW CARDS

Yellow cards can only be given for the behaviour on the water. A yellow card will be confirmed on a form which will be posted with the results. The pilot has 60 minutes to protest to the jury. If the protest is not accepted, he can appeal. Protests and appeals can be lodged according to U.I.M. rules.

A yellow card can be given by:

- the Officer of the Day;
- the U.I.M. Commissioner.

The yellow card can be given according to the following:

- up to two yellow cards at a time for dangerous driving;
- red card for extremely dangerous driving.

A driver who has been given three yellow cards or a red card loses his right to take part in the following competition of the World Championship (current season or following season).

All cards remain valid for the four following competitions of the Championship as from the date on which the last card was delivered. When the penalty of not racing at the next race has been applied, the 3 yellow cards are deleted through the penalty.

Timed trials, qualification race and final race count as one event.

An organiser/N.A. who has given one or more yellow cards to a driver must inform U.I.M. by telefax or mail within 3 days. U.I.M. will inform the next organiser/N.A. of a World Championship race or the Continental Championship about the delivery of such yellow cards. When a driver has done 4 races without yellow cards, his previous card(s) will be deleted from the listing.

Given yellow cards must be mentioned in the commissioner's report which must be distributed to all members of the relevant U.I.M. Formula commissioners panel.

## **6. COMMITTEE OF APPEAL**

Appeals will be handled according to the 400 Jurisdiction rules.

The delay to appeal is counted from the moment of the communication of the Jury decision to the interested parties and it is 48 hours.

The 24 hours of the Sunday do not count within the 48 hours to appeal.

Address, telephone and fax should be clearly mentioned on the appeal so that the U.I.M. can send any correspondence directly to the driver with copy to his N.A. The driver may agree on having no Appeal Committee meeting but to handle the appeal through telephone and fax - if possible - in order to limit the costs of the appeal.

## **7. SAFETY**

Races in Formula 500 are reserved only for boats conforming to the following specifications:

Minimumweight:180 kg Minimumlength:3.85m Cockpit mandatory

Minimum weight mentioned above is the weight of the complete rig weighed directly after the race, without driver, residual water but including residual fuel.

Minimum weight with driver: 260 kg

Reinforced cockpits are mandatory according to rule 509 for F500.

Before racing a craft with restraint system, all drivers must have passed an immersion test in a restraint system to ensure that they can exit a reinforced compartment successfully.

The immersion certificate should be provided by the National Authority of the driver and includes an immersion test in a simulated reinforced cockpit. The immersion test and the certificate must be renewed every 14 months.

A model for the certificate and instructions of how to perform an immersion test are available at the U.I.M. Secretariat.

All catamaran type hulls must have the deformable pickle forks according to rule 503.02.

Drivers must wear of flotation vest so constructed at the shoulders that a driver can be easily pulled of the cockpit.

Seats are mandatory for F1 cockpits and highly recommended for all other cockpit classes. See 509.08.

## **8. GENERAL**

### **FINANCIAL CONDITIONS**

1720 € prize money:

Distributed by the organiser to the drivers at the end of the race, before they leave the racing place (after the end of the protest time).

1st: 370 €

2nd: 250 €

3rd: 200 €

4th:	180 €
5th:	170 €
6th:	150 €
7th:	130 €
8th:	100 €
9th:	90 €
10th:	80 €

5000 € travelling money:

Travelling money for foreign participants is to be divided equally between the registered competing foreign drivers to a maximum of 400 E. Drivers who fail to send in their registered entry forms in due time, according to the advance programme/regulations, may lose all their travel money.

All prize and travel money must be paid in Euro. Organisers unable/unwilling to pay in Euro will have to pay an increase of 10 % on all the amounts due to the drivers.

All TV, film, media and commercial rights are the property of the U.I.M.

If the U.I.M. has a contracted promoter, he handles the rights on behalf of the U.I.M.

Any organisation wishing to film or to use existing film must contact the U.I.M. or the promoter.

Any correspondence regarding Formula 500 must be sent to the following address:

UNION INTERNATIONALE MOTONAUTIQUE  
STADE LOUIS II - ENTREE H  
1 AVENUE DES CASTELANS  
MC 98000 MONACO  
Fax: (377) 92-05-04-60  
E-mail: [uim@uimpowerboating.com](mailto:uim@uimpowerboating.com)  
Website: [www.uimpowerboating.com](http://www.uimpowerboating.com)



## **U.I.M. FORMULA 4 WORLD CHAMPIONSHIP**

1. ORGANISATION
2. RACE FORMAT
3. START
4. STOPPED RACE
5. RACE COURSE
6. CLASSIFICATION
5. EQUIPMENT
6. ENTRIES
7. YELLOW CARDS
8. COMMITTEE OF APPEAL
9. SAFETY
10. GENERAL

### **INTERPRETATION OF THE RULES - 200.02**

In all cases unforeseen by the international rules, the National Authority is to judge bearing in mind the spirit of the rules.

In case of conflicting rules, those rules concerning the series are to prevail.

#### **1. ORGANISATION**

The organisation of F4 races and championships is owned and ruled by the U.I.M.

The Council may update the rules whenever necessary, if the Formula is promoted by a contracted promoter.

Formula 4 races are reserved for boats of the S.850 class, governed by the rules 540.

The F4 World Championship is open to all drivers (their number is unlimited for each National Authority).

The Championship will be run in a maximum of 5 meetings organised in different countries, with a minimum of two weeks between races.

Provided that the number of applications is not sufficient, one single National Authority may be allowed to organise two meetings.

## 2. RACE FORMAT

It is recommended that each meeting of the F4 World Championship be composed of 4 parts that should take place within a period of two consecutive days, in conformity with U.I.M. rules on circuit races, further completed by the specific rules set hereafter.

The various parts of the meeting are as follows:

- 1) free practice (minimum 2 x 1 hour);
- 2) Mandatory timed trials:

***Timed trials must cover 12 laps maximum, all together during 45 minutes.***

***After, the top 6 boats will run 3 additional laps (for pole position classification, first lap : warm-up, 2 other laps : timed trials).***

2 series must be organised, except in a case of force majeure; All data concerning the trials and the number of authorised boats must be printed in the advance-programme.

Should the number of drivers at the race exceed the number of boats allowed on the circuit, a qualifying race will have to be organised. The composition of the qualifying series will be determined by the results obtained at the official timed trials; drivers in an odd-numbered position (1, 3, 5...) will be in one series, those in an even-numbered position (2, 4, 6...) will be in another series.

The drivers who have not taken part in trials will be distributed among the two series.

For each series there will be a selection race and some drivers will run a second chance race.

Example based on 30 boats on a circuit planned for 20 boats:

There will be two series of 15 boats.

At the end of the selection races for these series, the first eight boats in each series will be selected ( $2 \times 8 = 16$ ).

The second chance heat will be run by 14 unselected drivers; the first four in this boat will be allowed to take part in the final race ( $1 \times 4 = 4$ ).

That is to say total number of  $16 + 4 = 20$  drivers for the final race.

A minimum one-hour interval is required between final heats as well as between the last qualifying heat and the final heat.

Championship race - from 50 to 60 km.

The organiser is required to mention in the advance-programme the number of laps which is determined by the length of his circuit.

A U.I.M. Commissioner is required at each race.

No other class of boats is allowed to take part in Formula 4 Championship.

The maximum length of a straight line between two turning buoys is 850 meters.

The shortest time recorded by official timekeepers for each boat will determine the position of boats on the starting grid. Should a boat starting a race be different from the boat that was used for trials, it will be put in the last position on the starting grid.

If a race is shortened due to force majeure, it is at the discretion on the O.O.D. and the U.I.M. Commissioner to alter the time table and if necessary the course accordingly. In the event of no qualifying times being posted the grid will be drawn on current championship positions.

### **3. START**

The start will be dead engine start, as follows:

Dead engine start

Boats will be drawn up stern first, engine dead, to a jetty, a floating stage or beach.

The distance between the starting line and the first turning buoy must be at least 300 meters.

When the pontoon marshal is satisfied that all drivers are ready to start, with engines stopped, he raises a green flag and the O.O.D. starts the start procedure. He instructs the starter to raise a 30 seconds board (min. 80 x 80 cm, figures 60 x 10 cm).

30 seconds after this board is raised the red light is switched on.

After 5-12 seconds the red lights are switched off, this is the signal to start. These drivers rotating their engines (with ignition switched off) prior to the red lights going off lose one lap. This lap will be deducted at the end of the race.

The starter may decide if he judges it necessary, to cancel the start by presenting the red flag and recommence the starting procedure.

Before the start of the first race of each meeting of the Championship, when his name is called, each driver will lap the circuit to make it possible for the organiser to introduce him to the public.

### **4. STOPPED RACE**

In the event of the race being stopped boats will return to the starting pontoon, under their own power.

Drivers taking outside assistance at any point during the race (whether the race has been stopped for an incident or not) will be disqualified.

Boats that have broken down and pulled to the infield or off the race course will be towed to the trailer or the starting dock only during a «race stop» condition and if pick-up boats are available.

Only if the boat reaches the pontoon on its own power, repairs can be made on the rear side of the start pontoon or on the launching pontoon, while the boat is completely in the water or on its trailer. Further instructions for the repair area may be given at drivers briefing.

In case of a restart the boat being repaired must be ready to take its position on the grid at the instruction of the pontoon marshal. If the boat is not ready to take its position, it must start at the end of the pontoon.

Hulls and motors have to be sealed after scrutineering and before practice. In races with several restarts, substitution of hull or motors between the restarts or during the race is prohibited.

To qualify for points, a stopped race must be restarted if 70% of the total distance specified for the race has not been covered at the time the race is stopped.

The number of laps completed by the leading boat + 1 lap per restart will be deducted from the restarted race.

Should there be a restart, starting positions will be determined by the order of the end of the lap prior to the race being stopped.

All boats which are ready to race, may start in a restarted race. After the finish of the race, the race organiser might find out who has caused the stoppage of the race and the driver or drivers responsible for the stoppage, will not score.

## **5. RACE COURSE**

Water registration - see rule 106.02

Course and safety rules shall be those of the U.I.M. applicable on the date of the race unless specified otherwise by these rules.

The length of straight between any two turning buoys is to be a maximum of 850 metres. The boundaries of the water on which practice and racing are allowed to take place must be defined in the advance program.

The pit area should be sufficiently large to prevent boats being craned into the water over other boats.

There must be a minimum of 2 cranes.

Every turn on the race course must have two turn buoys.

If a driver

- touches the first turn buoy in a turn: no penalty;
- damages or destroys the first buoy: one lap penalty;
- touches the second buoy: no penalty;
- damages, destroys or dislodges the second buoy: disqualification;

The penalty lap will be deducted at the end of the race.

When passing a mark and an overlap has been established, both boats must maintain their lane, i.e. they must maintain their distance from the mark until the mark has been rounded.

## **6. CLASSIFICATION**

All boats will be classified taking into account the number of complete laps they have covered and for those which have completed the same number of laps, the order in which they crossed the arrival line.

The number of laps completed during the eventual restarts will be taken in account for the classification.

The points will be granted to the first 15 classified drivers on the condition that they have completed 90% of the number of laps covered by the winner (rounded down to the nearest whole number of laps).

The leading boat must have completed 70% of the number of laps counting for the race.

In the event of the race being stopped, boats will return to the start pontoon.

Drivers taking outside assistance at any point during the race (whether the race has been stopped for an incident or not) will be disqualified.

Boats that have broken down and pulled to the infield or off the race course will be towed to the trailer on the starting dock only during a «race stop» condition and if pick-up boats are available.

Only if the boat reaches the pontoon on its own power, repairs can be made on the rear side of the start pontoon or on the launching pontoon, while the boat is completely in the water or on its trailer. Further instructions for the repair area may be given at drivers briefing.

In case of a restart the boat being repaired must be ready to take its position on the grid at the instruction of the pontoon marshal. If the boat is not ready to take its position, it must restart at the end of the pontoon.

Only those drivers scored at the end of the lap before the stop are allowed to restart.

In case of a re-start, the positions on the grid are determined by the classification made at the end of the lap preceding the race stoppage.

If there is no re-start, the classification is the one established at the end of the lap preceding the stoppage of the race. The driver(s) responsible for the race stoppage are not classified.

Points will be granted according to the following schedule:

70 % or more of the total race total points;

less than 70 % half of the points;

less than 35 % no points.

The points awarded will be as follows:

1st: 20 points	6th: 10 points	11th: 5 points
2nd: 17 points	7th: 9 points	12th: 4 points
3rd: 15 points	8th: 8 points	13th: 3 points
4th: 13 points	9th: 7 points	14th: 2 points
5th: 11 points	10th: 6 points	15th: 1 point

The general classification of the F4 World Championship will be established by adding-up the points collected in each race of the Championship. In case of a tie, the number of first places and then 2nd

places, 3rd, etc... will be taken into account. In case of a last tie, all U.I.M. points (schedule 318.01) collected during all the races of the Championship will be added-up and will decide which of the drivers is the winner.

At the last race of the series U.I.M. will provide three medals (gold, silver, bronze) to be given to the three first classified in the general classification.

Immediately after the race, the first three in the meeting will be introduced to the public and to the media on the official podium. This introduction is only a provisional classification subject to modification after the developments of the race and the protests, if any, have been examined.

The first six classified boats are weighed with scales when coming out of the water. The weighing of the boats can not be protested. The scales will be available before the meeting commences.

## **7. EQUIPMENT**

### **ENGINES**

F4 driver's World Championship is reserved to boats equipped with one single naturally aspirated outboard engine complying with the requirements contained in rules 540 regarding class S.850.

### **FUEL**

- a. General fuel rules 508 will apply;
- b. Fuel will be supplied by the organiser in conformity with rule 508.01;
- c. Unleaded sports engine fuel in rule 508.02 will apply.

### **HULL**

All boats must be equipped with an isolation switch placed as close as possible to the positive pole of the battery(ies) (negative pole if the earthing is done via the positive pole). The handle of this switch must be easily reached on the deck or any other surface of the boat (preferably on the portside, 1 to 3 meters from the stern). The switch should be indicated by a red arrow and clearly show the ON/OFF positions.



The weight of the boat, driver and personal equipment included: 330 kg minimum (250 kg minimum for the boat plus 80 kg for the driver).

The minimum length is 3.90 m measured along the sponson.

Reinforced cockpit is mandatory.

No entry shall be considered official before the boat has passed the scrutineering and the document controls.

## **8. ENTRIES**

Each National Authority is fully responsible for its driver's qualification. Registration forms will have to bear the authorisation to start delivered by the National Authority of the competitor (U.I.M. 203.01 - 1 st paragraph).

All holders of an international licence will be allowed to take part in races.

## **9. YELLOW CARDS**

Yellow cards can only be given for the behaviour on the water. A yellow card will be confirmed on a form which will be posted with the results. The pilot has 60 minutes to protest to the jury. If the protest is not accepted, he can appeal. Protests and appeals can be lodged according to U.I.M. rules.

A yellow card can be given by:

- the Officer of the Day;
- the U.I.M. Commissioner.

The yellow card can be given according to the following:

- up to two yellow cards at a time for dangerous driving;
- red card for extremely dangerous driving.

A driver who has been given three yellow cards or a red card loses his right to take part in the following competition of the World Championship or Continental Championship (current season or following season). All

cards remain valid for the four following competitions of the Championship as from the date on which the last card was delivered. When the penalty of not racing at the next race has been applied, the 3 yellow cards are deleted through the penalty.

Participating in training, timed trials and final race will be considered as having done one event.

An organiser/N.A. who has given one or more yellow cards to a driver must inform U.I.M. by telefax or mail within 3 days. U.I.M. will inform the next organiser/N.A. of a World Championship race or the Continental Championship about the delivery of such yellow cards. When a driver has done 4 races without yellow cards, his previous card(s) will be deleted from the listing.

Given yellow cards must be mentioned in the commissioner's report which must be distributed to all members of the relevant U.I.M. Formula commissioners panel.

Temporary suspension: see article 406.05

## **10. COMMITTEE OF APPEAL**

Appeals will be handled according to the 400 Jurisdiction rules.

The delay to appeal is counted from the moment of the communication of the Jury decision to the interested parties and it is 48 hours.

The 24 hours of the Sunday do not count within the 48 hours to appeal.

Address, telephone and fax should be clearly mentioned on the appeal so that the U.I.M. can send any correspondence directly to the driver with copy to his N.A. The driver may agree on having no Appeal Committee meeting but to handle the appeal through telephone and fax - if possible - in order to limit the costs of the appeal.

## **11. SAFETY**

Reinforced cockpits are mandatory according to rule 509.

Before racing a craft with restraint system, all drivers must have passed an immersion test in a restraint system to ensure that they can exit a reinforced compartment successfully.

The immersion certificate should be provided by the National Authority of the driver and includes an immersion test in a simulated reinforced cockpit. The immersion test and the certificate must be renewed every 14 months.

A model for the certificate and instructions of how to perform an immersion test are available at the U.I.M. Secretariat.

The deformable pickle forks are mandatory according to rule 503.02.

Life jackets incorporating pants, are mandatory.

Seats are mandatory for F1 cockpits and highly recommended for all other cockpit classes. See 509.08.

Drivers must wear of flotation vest so constructed at the shoulders and the legs that a driver can be easily pulled of the cockpit.

## **12. GENERAL**

### **FINANCIAL CONDITIONS**

Each National Authority wishing to organise a Formula 4 race will have to guarantee the amount of 2000 € to be distributed as follows:

2000 € prize money:

Distributed by the organiser to the drivers at the end of the race, before they leave the racing place (after the end of the protest time).

1st:	340 €
2nd:	290 €
3rd:	250 €
4th:	220 €
5th:	200 €
6th:	180 €

7th:	160 €
8th:	140 €
9th:	120 €
10th:	100 €

500 € year end prize money:

To be deposited at U.I.M. BEFORE the 28th February of the year of the organisation, for the prize money of the general classification of the Championship.

The year end prize money will be paid by U.I.M. after the last race, according to the general classification of the championship and after examining all possible protests: 4 € for each point accumulated by each driver in the general classification.

All TV, film, media and commercial rights are the property of the U.I.M.

The U.I.M. contracted promoter handles the rights on behalf of the U.I.M.

Any organisation wishing to film or to use existing film must contact the promoter.

All correspondence related to the F4 World Championship should be sent to the following address:

UNION INTERNATIONALE MOTONAUTIQUE  
STADE LOUIS II - ENTREE H  
1 AVENUE DES CASTELANS  
MC 98000 MONACO  
Fax: (377) 92-05-04-60  
E-mail: [uim@uimpowerboating.com](mailto:uim@uimpowerboating.com)  
Website: [www.uimpowerboating.com](http://www.uimpowerboating.com)

## **U.I.M. FORMULA 1000 INTERNATIONAL**

1. DENOMINATION
2. HULL
3. MOTOR
4. PROPELLER
5. FUEL
6. YELLOW CARDS
7. COMMITTEE OF APPEAL
8. SAFETY
9. GENERAL

## **TECHNICAL RULES**

### **1. DENOMINATION**

The Formula 1000 European Championship is an outboard monobrand class.

The Championship includes up to 4 races organised in different countries.

The final classification of each of these four events will be calculated using the drivers' best three heats and the 25 % reducing points system (400, 300, 225 etc).

The overall classification of the European Championship will be calculated by awarding points for positions in the final classification of each of the four events using the 20, 17, 15 etc points system.

The heat distance will be 20 to 25 km.

## 2. HULL

- 2.1. The hull must be of a catamaran type provided with safety cockpit and pickle-forks in accordance with the U.I.M. rules. The minimum dimensions must be the following:

minimum length 3,90 m;

minimum weight of the boat 250 kg (325 kg with driver) immediately after the race with residual fuel and without residual water.

- 2.2. ***Radios in boats are mandatory and a full radio check of each boat will be part of technical scrutineering in order to guarantee that all radios are working. The radioman must be present at race control whenever his boat is on the course. In order to guarantee clear communication between the Team Managers and the U.I.M. Commissioner, all Team Managers must speak English.***

## 3. MOTOR

The motor must be a SELVA FORMULA 1000 homologated by U.I.M.

The electric supply of the system must be 12 Volt (including trim system).

The lift system is mechanic and must be not modified. Any machinery aimed at modifying the height of the motor during the race is forbidden.

Carburettors must remain standard in any of their parts.

Cylinder sleeves cannot be substituted and cannot undergo any remarking.

The cooling water must circulate through the water pump and be fed only through the standard water intake, neither the position nor the shape of which may be modified.

The use of non SELVA parts are forbidden.

Sole modifications allowed:

- It is permissible to use any ignition wire, spark plugs (not exceeding into combustion chamber), propeller nut;
- It is permissible to use any fuel line or fittings. A fuel filter may also be used;
- It is possible to add a fuel supply electric pump without changing the original system of engine supply;
- It is permissible to replace original carburettor jets for another size.

Reworking of the parts is allowed within the manufacture geometrical dimension tolerances as from the technical schedule provided by the manufacturer.

In order not to modify the crankshaft balancing of the standard production engine it is not allowed to remove or add material, in any way, to the components of crankshaft, connecting rods, complete pistons, bearings and pins assembly.

Apart from the above provisions, it is absolutely forbidden to make any alterations to the engine manufacturers standard components either by removal or addition of material. In particular this includes components being subjected to any form of machining, grinding, hand tooling, reworking, reshaping, fettling, polishing etc. unless it is specifically permitted.

The driver is responsible for the condition of the engine as raced. Errors on the part of one manufacturer, mechanic or previous owner is no excuse.(528.10.19)

Post race inspection should follow rules 502.2

## **4. PROPELLER**

The propeller must not have more than 4 (four) blades.

## 5. FUEL

The fuel must be of commercial type used for automobile. Lubricating oil for cylinder head or for 2-stroke motors may be added to the fuel.

The use of additives aiming at increasing the power of the motor is prohibited either to the fuel (carburant) or to the air intake (comburant).

No refuelling will be allowed when the boat is not on its trailer.

When fuel is available at race site, minimum 92 octane, and the specification and price is printed in the advance programme, all competitors must use the specified fuel.

## 6. YELLOW CARDS

Yellow cards can only be given for the behaviour on the water. A yellow card will be confirmed on a form which will be posted with the results. The pilot has 60 minutes to protest to the jury. If the protest is not accepted, he can appeal. Protests and appeals can be lodged according to U.I.M. rules.

A yellow card can be given by:

- the Officer of the Day;
- the U.I.M. Commissioner.

The yellow card can be given according to the following:

- up to two yellow cards at a time for dangerous driving;
- red card for extremely dangerous driving.

A driver who has been given three yellow cards or a red card loses his right to take part in the following competition of the World Championship (current season or following season).

All cards remain valid for the four following competitions of the Championship as from the date on which the last card was delivered. When the penalty of not racing at the next race has been applied, the 3 yellow cards are deleted through the penalty.



Timed trials, qualification race and final race count as one event.

An organiser/N.A. who has given one or more yellow cards to a driver must inform U.I.M. by telefax or mail within 3 days. U.I.M. will inform the next organiser/N.A. of a World Championship race or the Continental Championship about the delivery of such yellow cards. When a driver has done 4 races without yellow cards, his previous card(s) will be deleted from the listing.

Given yellow cards must be mentioned in the commissioner's report which must be distributed to all members of the relevant U.I.M. Formula commissioners panel.

## **7. COMMITTEE OF APPEAL**

Appeals will be handled according to the 400 Jurisdiction rules.

The delay to appeal is counted from the moment of the communication of the Jury decision to the interested parties and it is 48 hours.

The 24 hours of the Sunday do not count within the 48 hours to appeal.

Address, telephone and fax should be clearly mentioned on the appeal so that the U.I.M. can send any correspondence directly to the driver with copy to his N.A. The driver may agree on having no Appeal Committee meeting but to handle the appeal through telephone and fax - if possible - in order to limit the costs of the appeal.

## **8. SAFETY**

Before racing a craft with restraint system, all drivers must have passed an immersion test in a restraint system to ensure that they can exit a reinforced compartment successfully.

The immersion certificate should be provided by the National Authority of the driver and includes an immersion test in a simulated reinforced cockpit. The immersion test and the certificate must be renewed every 14 months.

A model for the certificate and instructions of how to perform an immersion test are available at the U.I.M. Secretariat.

All catamaran type hulls must have the deformable pickle forks according to rule 503.02.

Drivers must wear of flotation vest so constructed at the shoulders that a driver can be easily pulled of the cockpit.

Seats are mandatory for F1 cockpits and highly recommended for all other cockpit classes. See 509.08

## **9. GENERAL**

All TV, film, media and commercial rights are the property of the U.I.M.

If the U.I.M. has a contracted promoter, he handles the rights on behalf of the U.I.M.

Any organisation wishing to film or to use existing film must contact the U.I.M. or the promoter.

Any correspondence regarding Formula 1000 must be sent to the following address:

UNION INTERNATIONALE MOTONAUTIQUE  
STADE LOUIS II - ENTREE H  
1 AVENUE DES CASTELANS  
MC 98000 MONACO  
Fax: (377) 92-05-04-60  
E-mail: [uim@uimpowerboating.com](mailto:uim@uimpowerboating.com)  
Website: [www.uimpowerboating.com](http://www.uimpowerboating.com)

## **GENERAL FOR ALL FORMULAE RACES**

### **MATCH RACE RULES**

Qualifying from time trial position. (numbers on sheet are timed trial qualifying positions).

Qualifying matrix for 16 boats

- First elimination round
- Quarter-finals
- Semi-finals
- Third place race
- Final

Qualifying matrix for 8 boats

- First elimination round
- Semi-finals
- Third place race
- Final

Course

- Three pin course (by a straight line)
- Round the first turning buoy it should be a sausage buoy (safety zone) to keep the lane for both drivers
- The third buoy is the same for both drivers
- Finish line is the same for both drivers
- Both drivers do one long and one short lap
- The longest lap should not be more than 800 m total

Start

- By light
- From a pontoon
- Side by side
- Inside driver go for the shortest lap

- The outside driver goes for the furthest buoy
- With double heat the driver switch lanes
- If a driver does not start the other driver must complete the course

#### Finish single heat

- The driver who passing the finish line first is the winner of this Match Race heat, there may be time keeping, if required for minor places overall position.

#### Finish double heat

- The driver who made the best average time is the winner of the double heat

#### Penalties (disqualification)

- Non-start
- Jump start
- Cutting course
- Impeding other course

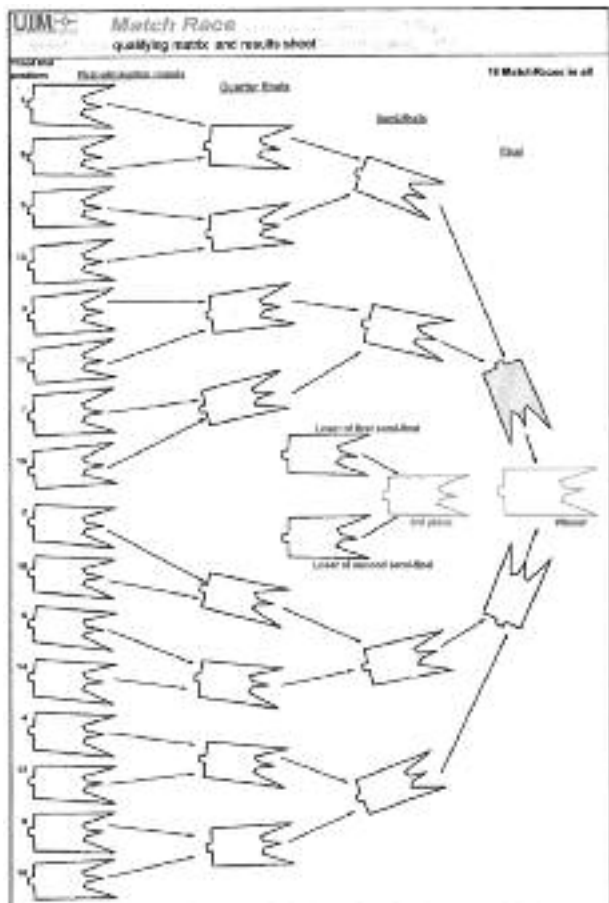

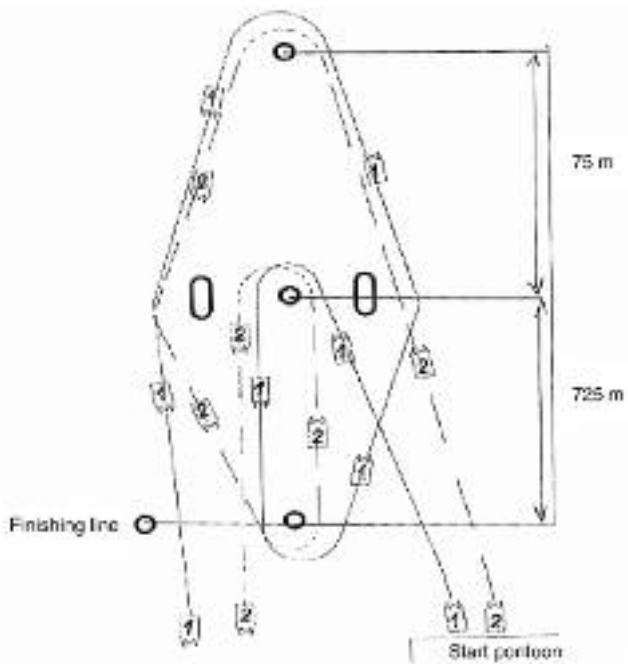

START PONTOON  
ANGLED TO GIVE  
SAME DISTANCE  
FOR BOTH START LINES

## **GENERAL FOR ALL FORMULAE RACES CODE OF PRACTICE FOR SAFETY**

### **1) RESCUE BOATS**

Must be high speed, drop front (boats) which produce a minimum disturbance of the water.

There must be a minimum of two rescue boats along the circuit so placed that they can reach in the minimum possible time any point of the course. Their locations and their co-ordination must be decided in a meeting among the O.O.D., the Medical Officer, the rescue Teams responsible and the U.I.M. Commissioners before first practice.

These boats shall be equipped as a minimum as follows:

- a floating stretcher,
- belt cutters,
- one fire extinguisher,
- ropes (including tow ropes),
- an anchor,
- an haemostatic strip,
- bandages,
- a set of flags,
- red flares.

All these boats shall be in contact with each other, with the medical post and the O.O.D. with a radio equipment that has to be used without interfering with the driving and the rescue operations.

These boats shall not be allowed to carry on towing duties during the practice sessions and the race.

### **2) CREW MEMBERS**

Each boat shall carry the following persons:

- an experienced driver,
- two crew members prepared and equipped to enter the water to support any injured driver and who are familiar with any safety equipment used on racing boats.

No pilot shall be pulled or assisted into any rescue boat; no pilot shall be removed from the water unless the whole body is supported by a stretcher. No other boat shall be allowed to pull or assist any injured driver.

### **3) MEDICAL ASSISTANCE**

A minimum of three doctors are required at each event:

- The Medical Officer, a doctor well introduced in powerboat racing problems acting as the co-ordinator of the medical team;
- a doctor graduated in resuscitation responsible for the medical post where he has to be available during the practice sessions and the race;
- a doctor graduated in resuscitation operating on one of the three rescue boats in addition to the existing crew. He shall carry on the boat all the equipment necessary for first aid assistance (a water sucker, intra tracheal tubes, Mayo cannulae, oxygen supply and do on).

### **4) GROUND ORGANISATION**

Apart from the medical post reserved for the public each event must have a private post (minimum a tent) where an injured driver may be taken after initial resuscitation before being moved to the nearest hospital.

This medical post has to be located as close as possible to the rescue boat landing site. This has to be in a reserved area (not accessible to the public) and must be adequate for an easy and safe of the transfer operation injured driver. It is very important that the landing site and the medical post are located close to the race course even if far from the pits area. A nearby closed area for an helicopter is recommended.

A minimum of two ambulances is required. At least one of them must be equipped as a mobile resuscitation centre. They will be located close to



the medical post and must have easy and constantly open access from the medical post to the road leading to the hospital.

A general hospital shall be informed about the Event and prepared to take care of an injured driver.

The Medical Officer, according to any specific situation, may ask the O.O.D. to adjust the rescue and medical organisation (increasing the number of rescue boats, ambulances and doctors) in order to maintain a minimum standard of assistance.

The presence and the employment of local teams able to work with the required equipment and efficiency are recommended.

## **ELECTIONS OF THE DRIVERS' DELEGATE**

### **FOR F1, F2**

The election must be held in the presence of a U.I.M. official. The candidate must be a real driver (4 races or 40% of the total rounded up to the next unit); he is elected for a three year period provided he keeps within the limits of eligibility. The drivers' assembly may intervene if the delegate is not suitable any longer.



## 205.03 - MEDICAL EVALUATION SHEET 2010 F1 & F2 SUPERLICENCE

Location of test \_\_\_\_\_ Date \_\_\_\_\_

Name \_\_\_\_\_ Surname \_\_\_\_\_

Born in \_\_\_\_\_ Date \_\_\_\_\_

Status \_\_\_\_\_ Profession \_\_\_\_\_

Date of first involvement in the sport \_\_\_\_\_

Other sports practised \_\_\_\_\_

### PRESENT STATE OF HEALTH AND FORMER DISEASES

Disease (former or current) \_\_\_\_\_

\_\_\_\_\_

With special mention of \_\_\_\_\_

Cardiopathy     Coronary     Diabetes Type 1 / 2 (circle the type)

Epilepsy     High Blood Pressure

Operations undergone previously \_\_\_\_\_

Dates of these operations \_\_\_\_\_

Accidents (when, where, under which circumstances) \_\_\_\_\_

\_\_\_\_\_

\_\_\_\_\_

Alcohol \_\_\_\_\_ Tobacco \_\_\_\_\_

Allergies \_\_\_\_\_

Medicines usually/frequently taken \_\_\_\_\_

## 205.04 – GENERAL OBJECTIVE EXAMINATION 2010 F1 & F2 SUPERLICENCE

Height: \_\_\_\_\_ Weight: \_\_\_\_\_

Body Mass Index (Weight (kg)/Height<sup>2</sup>(m): BMI): \_\_\_\_\_

Any driver with a BMI over 30 kg/m<sup>2</sup> in 2010 must submit in 2010 with his 2010 superlicence application, all detailed examination results required in this form.

This will then be submitted to a doctor appointed by the UIM.

Drivers have until the medical test in 2011 to reduce their BMI to less than 30 kg/m<sup>2</sup>.

The 2010 year is a transition period and no one with a BMI over 30 kg/m<sup>2</sup> will be issued a superlicence in 2011.

Age \_\_\_\_\_ Sex \_\_\_\_\_

Congenital or acquired deformities \_\_\_\_\_

Respiratory system \_\_\_\_\_

Spirometry (mandatory) \_\_\_\_\_

FVC (measured/predicted) \_\_\_\_\_

FEV<sub>1</sub> (measured/predicted) \_\_\_\_\_

Cardiovascular system: is there any evidence of abnormality of the heart or cardiovascular system?  Yes  No

If "Yes", give details below.

\_\_\_\_\_  
\_\_\_\_\_

Blood Pressure at rest \_\_\_\_\_

Heart Frequency at rest \_\_\_\_\_

Electrocardiogram at rest \_\_\_\_\_

Stress ECG and blood pressure profile (see additional items) \_\_\_\_\_

\_\_\_\_\_  
\_\_\_\_\_

Sight testing (*see additional items*)

Date of the last ophthalmologic check-up (performed by a professional ophthalmologist): . . / . . / . . . .

Faculty of vision (uncorrected) R \_\_\_\_\_ L \_\_\_\_\_

(with correction) R \_\_\_\_\_ L \_\_\_\_\_

Vision with both eyes open (wearing corrective lenses if necessary) \_\_\_\_\_

Field of Vision \_\_\_\_\_

Vision of Colours: is the applicant's colour vision normal?  Yes  No

If "No", give details below.

Hearing Testing \_\_\_\_\_

Urine: Albumine \_\_\_\_\_ Sugar \_\_\_\_\_

Is the Urine analysis normal?  Yes  No

If "No", give details below.

Nervous system \_\_\_\_\_

Others \_\_\_\_\_

- Does the applicant have any physical abnormality or restriction of movements in the arms or legs?  Yes  No

If "Yes", give details below.

- Is there any evidence of a physical or mental condition (past or present) which could, in your opinion, prevent the applicant from holding a competition licence for motor sport?

Yes  No

If "Yes", give details below.

**To the Doctor and the Driver :**

Are you the applicant's usual doctor?  Yes  No

Your practice stamp (together with your name and qualifications):



Name in Capital Letters \_\_\_\_\_

Degree \_\_\_\_\_

Address \_\_\_\_\_

\_\_\_\_\_

Tel \_\_\_\_\_

Fax \_\_\_\_\_

Aptitude Assessment \_\_\_\_\_

Date \_\_\_\_\_

This is to certify that I have examined the applicant in line with this form.

**Signature of the Doctor** \_\_\_\_\_

**Signature of the Driver** \_\_\_\_\_



**ADDITIONAL ITEMS FOR SUPERLICENCE (IMPORTANT)**

Stress ECG and blood pressure profile: electrocardiogram has to be performed under stress on a **cycloergometer** starting at 60 watts and increasing by 30 watts every two minutes. The driver must be capable of reaching a minimum power level of 2.5 watts (males) – 2.2 watts (females) per kilogram of body weight.

**Treadmill tests are no longer accepted.**

A written report from the physician (English language) should be enclosed.

Exhaustive ophthalmological check-up, tested and certified (English language) by a professional ophthalmologist to be renewed every five years and after skull trauma.

Achévé d'imprimer sur les presses de  
MULTIPRINT - MONACO  
en février 2010  
(69879)